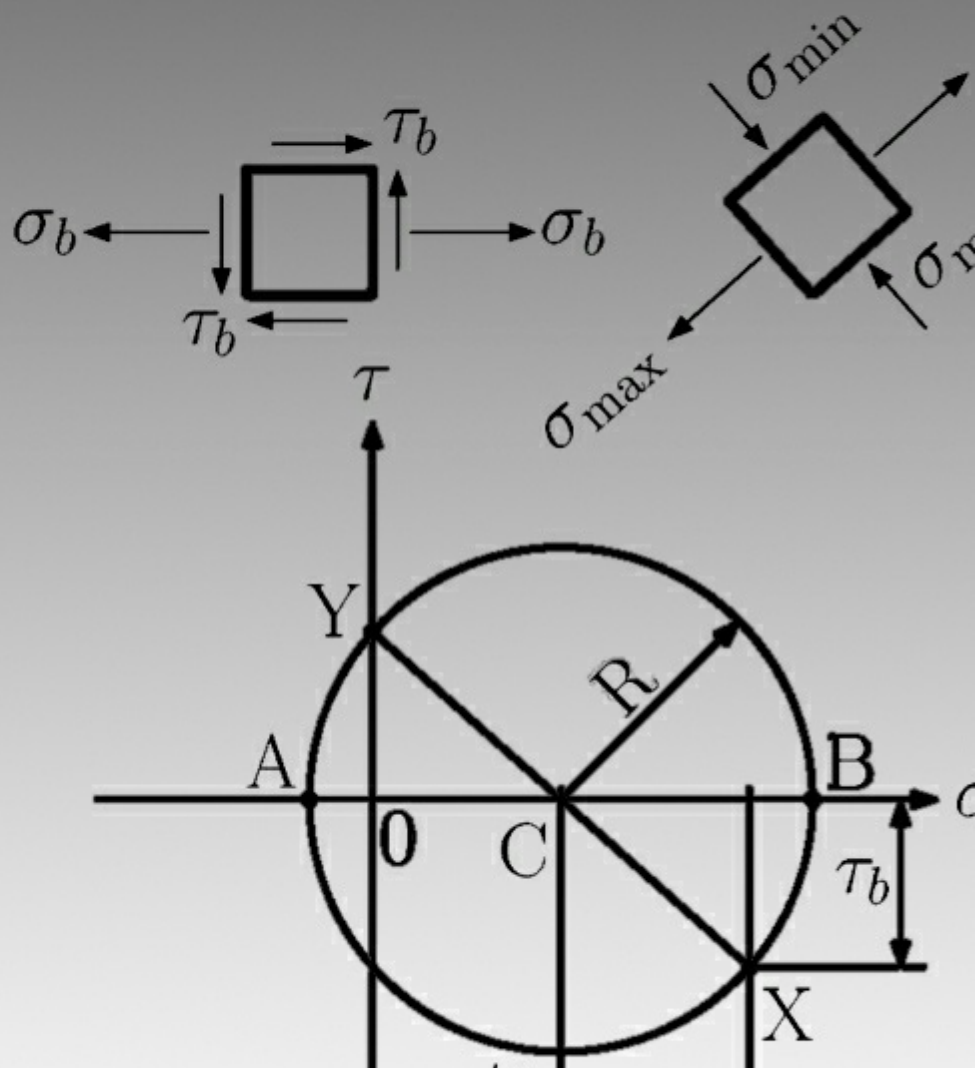


Branislav Hučko; Roland Jančo

# Introduction to Mechanics of Materials: Part II



Roland Jančo & Branislav Hučko

# **Introduction to Mechanics of Materials:**

## Part II



Introduction to Mechanics of Materials: Part II

First Edition

© 2013 Roland Jančo, Branislav Hučko & [bookboon.com](http://bookboon.com)

ISBN 978-87-403-0366-7

# Contents

	<b>List Of Symbols</b>	<b>9</b>
	<b>Preface</b>	<b>11</b>
<b>1</b>	<b>Introduction – Concept of stress</b>	<b>Part I</b>
1.1	Introduction	Part I
1.2	A Short Review of the Methods of Statics	Part I
1.3	Definition of the Stresses in the Member of a Structure	Part I
1.4	Basic Stresses (Axial, Normal, Shearing and Bearing stress)	Part I
1.5	Application to the Analysis and Design of Simple Structures	Part I
1.6	Method of Problem Solution and Numerical Accuracy	Part I
1.7	Components of Stress under General Loading Conditions	Part I
1.8	Design Considerations and Factor of Safety	Part I
<b>2</b>	<b>Stress and Strain – Axial Loading</b>	<b>Part I</b>
2.1	Introduction	Part I
2.2	Normal Stress and Strain under Axial Loading	Part I



Discover the truth at [www.deloitte.ca/careers](http://www.deloitte.ca/careers)

**Deloitte.**

© Deloitte & Touche LLP and affiliated entities.



Click on the ad to read more

2.3	Stress-Strain Diagram, Hooke's Law, and Modulus of Elasticity	Part I
2.4	Poisson's Ratio	Part I
2.5	Generalised Hooke's Law for Multiaxial Loading	Part I
2.6	Saint Venant's Principle	Part I
2.7	Deformations of Axially Loaded Members	Part I
2.8	Problems Involving Temperature Changes	Part I
2.9	Trusses	Part I
2.10	Examples, Solved and Unsolved Problems	Part I
<b>3</b>	<b>Torsion</b>	<b>Part I</b>
3.1	Introduction	Part I
3.2	Deformation in a Circular Shaft	Part I
3.3	Stress in the Elastic Region	Part I
3.4	Angle of Twist in the Elastic Region	Part I
3.5	Statically indeterminate Shafts	Part I
3.6	Design of Transmission Shafts	Part I
3.7	Torsion of Non-Circular Members	Part I
3.8	Thin-Walled hollow Members	Part I
3.9	Examples, Solved and Unsolved Problems	Part I

© 2013 Accenture. All rights reserved.

be > your degree

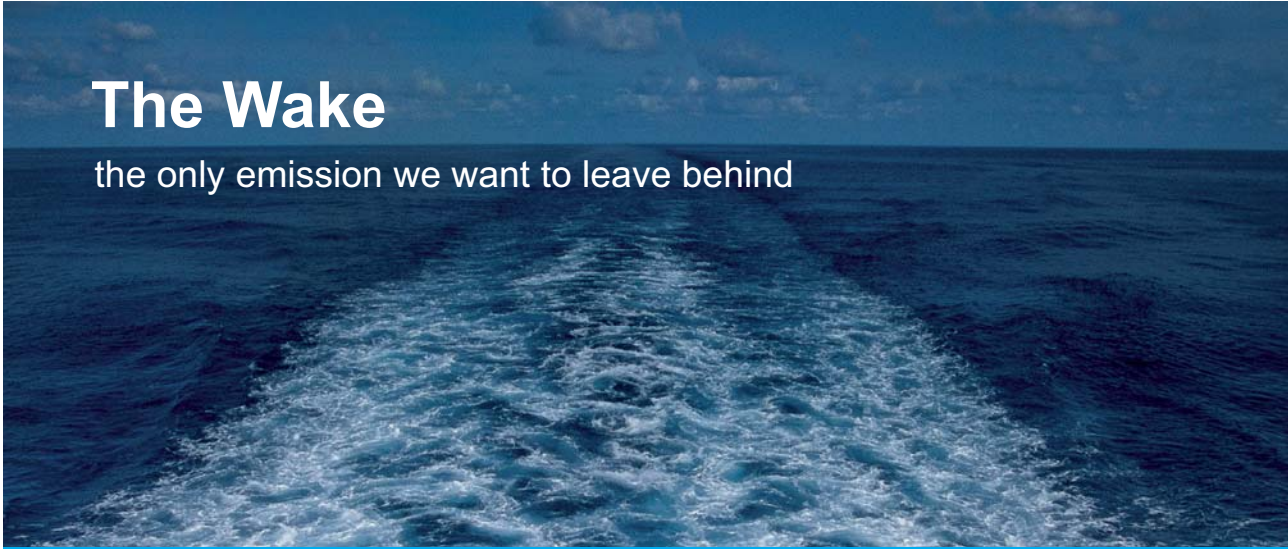
Bring your talent and passion to a global organization at the forefront of business, technology and innovation. Discover how great you can be.

Visit [accenture.com/bookboon](http://accenture.com/bookboon)

**Be greater than.**  
consulting | technology | outsourcing

**accenture**  
High performance. Delivered.

<b>4</b>	<b>Bending of Straight Beams</b>	<b>12</b>
4.1	Introduction	12
4.2	Supports and Reactions	13
4.3	Bending Moment and Shear Force	15
4.4	Shear and Bending Moment Diagrams	16
4.5	Relations among Load, Shear, and the Bending Moment	21
4.6	Definition of Normal and Shearing Stresses	23
4.7	Design of Straight Prismatic Beams	36
4.8	Examples, Solved and Unsolved Problems	46
<b>5</b>	<b>Deflection of Beams</b>	<b>89</b>
5.1	Introduction	89
5.2	Integration method	89
5.3	Using a Singularity Function to Determine the Slope and Deflection of Beams	94
5.4	Castigliano's Theorem	95
5.5	Deflections by Castigliano's Theorem	99
5.6	Statically Indeterminate Beams	102
5.7	Examples, solved and unsolved problems	103




**The Wake**  
the only emission we want to leave behind

Low-speed Engines Medium-speed Engines Turbochargers Propellers Propulsion Packages PrimeServ

The design of eco-friendly marine power and propulsion solutions is crucial for MAN Diesel & Turbo. Power competencies are offered with the world's largest engine programme – having outputs spanning from 450 to 87,220 kW per engine. Get up front!  
Find out more at [www.mandieselturbo.com](http://www.mandieselturbo.com)

Engineering the Future – since 1758.  
**MAN Diesel & Turbo**



<b>6</b>	<b>Columns</b>	<b>155</b>
6.1	Introduction	155
6.2	Stability of Structures	155
6.3	Euler's formulas for Columns	159
6.4	Design of Columns under a Centric Load	166
6.5	Design of Columns under an Eccentric Load	168
6.6	Examples, solved and unsolved problems	171
	<b>Appendix</b>	<b>208</b>
A.1	Centroid and first moment of areas	208
A.2	Second moment, moment of areas	211
A.3	Parallel axis theorem	217
A.4	Product of Inertia, Principal Axes	224
A.5	Strain energy for simple loads	226
	<b>References</b>	<b>233</b>

FREE  
30 days trial!


# SMS from your computer

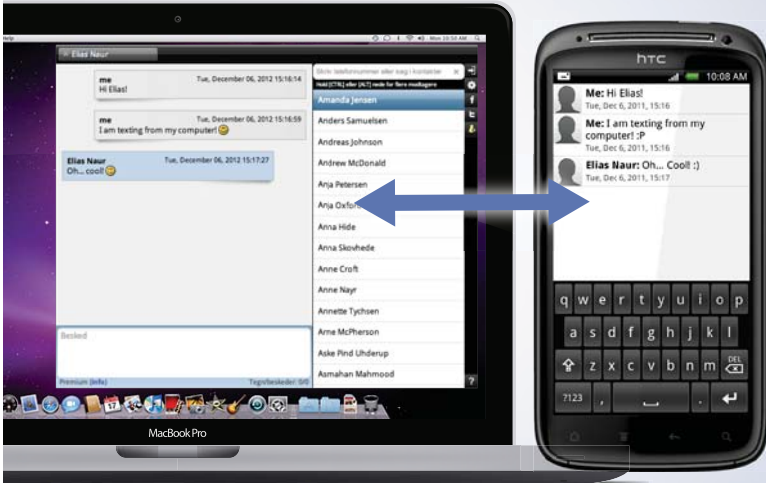
...Sync'd with your Android phone & number

Go to

[BrowserTexting.com](http://BrowserTexting.com)

and start texting from your computer!





The first part of this book is available in  
**"Introduction to Mechanics of Materials: Part I"**

# List Of Symbols

A	Area
b	width
B.C.	buckling coefficient
D	diameter
E	modulus of elasticity, Young's modulus
$f_s$	shearing factor
F	external force
F.S.	factor of safety
G	modulus of rigidity
h	height
$I_z, I_y$	second moment, or moment of inertia, of the area A respect to the z or y axis
$J_o$	polar moment of inertia of the area A
L	length
DL	elongation of bar
M	bending moment, couple
N	normal or axial force
$Q_z, Q_y$	first moment of area with respect to the z or y axis
$r_z$	radius of gyration of area A with respect to the z axis
R	radius
$R_i$	reaction at point i
s	length of centreline
T	torque
t	thickness
$\Delta T$	change of temperature
u	strain energy density
U	strain energy
V	volume
V	transversal force
w	uniform load
y(x)	deflection
A	area bounded by the centerline of wall cross-section area
$\alpha$	coefficient of thermal expansion (in chapter 2)
$\alpha$	parameter of rectangular cross-section in torsion
$\gamma$	shearing strain
$\epsilon$	strain
$\phi$	angle of twist
$\Theta_i$	slope at point i
$\tau$	shearing stress

$\tau_{\text{all}}$	allowable shearing stress
$\sigma$	stress or normal stress
$\sigma_{\text{all}}$	allowable normal stress
$\sigma_{\text{max}}$	maximum normal stress
$\sigma_{\text{Mises}}$	von Mises stress
$\sigma_{\text{N}}$	normal or axial stress

# Preface

This book presents a basic introductory course to the mechanics of materials for students of mechanical engineering. It gives students a good background for developing their ability to analyse given problems using fundamental approaches. The necessary prerequisites are the knowledge of mathematical analysis, physics of materials and statics since the subject is the synthesis of the above mentioned courses.

The book consists of six chapters and an appendix. Each chapter contains the fundamental theory and illustrative examples. At the end of each chapter the reader can find unsolved problems to practice their understanding of the discussed subject. The results of these problems are presented behind the unsolved problems.

Chapter 1 discusses the most important concepts of the mechanics of materials, the concept of stress. This concept is derived from the physics of materials. The nature and the properties of basic stresses, i.e. normal, shearing and bearing stresses; are presented too.

Chapter 2 deals with the stress and strain analyses of axially loaded members. The results are generalised into Hooke's law. Saint-Venant's principle explains the limits of applying this theory.

In chapter 3 we present the basic theory for members subjected to torsion. Firstly we discuss the torsion of circular members and subsequently, the torsion of non-circular members is analysed.

In chapter 4, the largest chapter, presents the theory of beams. The theory is limited to a member with at least one plane of symmetry and the applied loads are acting in this plane. We analyse stresses and strains in these types of beams.

Chapter 5 continues the theory of beams, focusing mainly on the deflection analysis. There are two principal methods presented in this chapter: the integration method and Castigliano's theorem.

Chapter 6 deals with the buckling of columns. In this chapter we introduce students to Euler's theory in order to be able to solve problems of stability in columns.

In closing, we greatly appreciate the fruitful discussions between our colleagues, namely prof. Pavel Élesztős, Dr. Michal Čekan. And also we would like to thank our reviewers' comments and suggestions.

Roland Jančo  
Branislav Hučko

# 4 Bending of Straight Beams

## 4.1 Introduction

In the previous Chapters we have discussed axial loading by vector analysis, i.e. the vectors of applied forces and moments coincide with the direction of the member's axes. Now we are going to investigate *transverse loading*, i.e. the applied loads cause that some of the internal force and moment vectors to be perpendicular to the axis of the member, see Fig. 4.1. The presented bar in the clamp, used for gluing sheets of plywood together, is subjected to the *bending moment*  $M = Fd$  and the normal force  $N = F$ . The cantilever beam is subjected to the bending moment  $M_{(x)} = Fx$  and the *shear* or *transverse force*  $V_{(x)} = Fx$ . In these cases, where perpendicular internal moment vectors are contained, the members are subjected to *bending*. Our discussion will be limited to the bending of straight prismatic members with at least one plane of symmetry at the cross-sections, see Fig. 4.2. The applied loads are exerted in the plane of symmetry, see Fig. 4.3. Under these limitations we will analyse stresses and strains in members subjected to bending and subsequently discuss the design of straight prismatic beams.

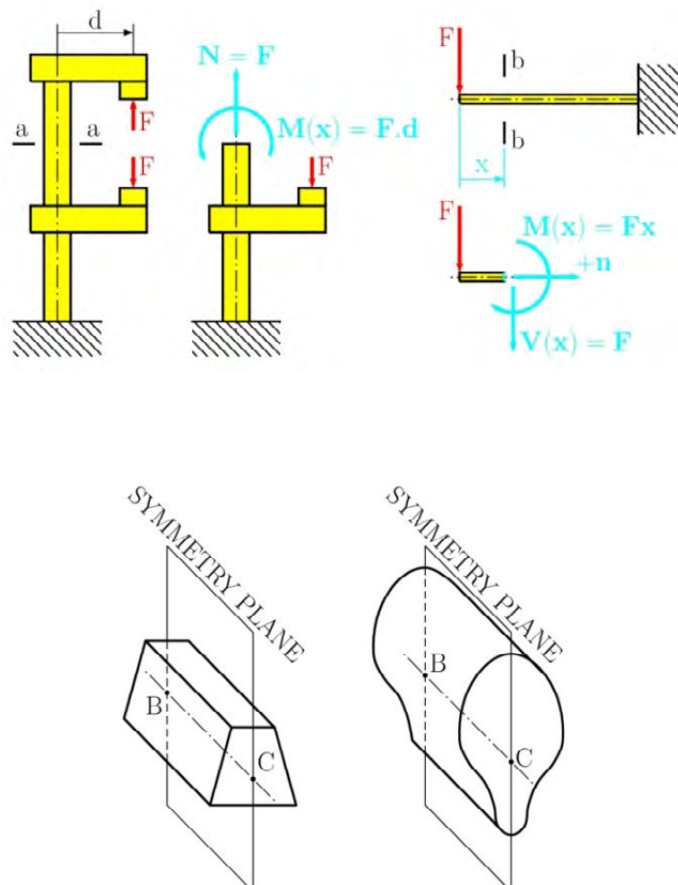


Fig. 4.2

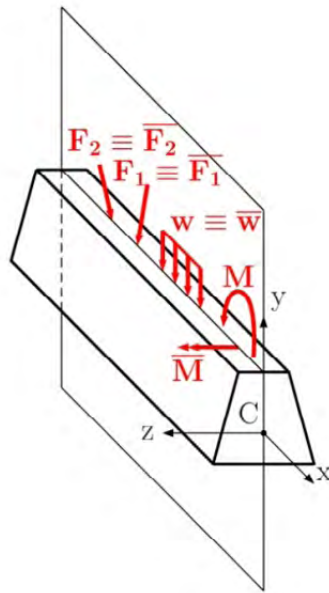


Fig. 4.3

## 4.2 Supports and Reactions

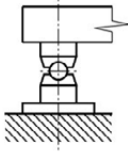
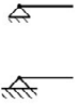
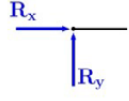
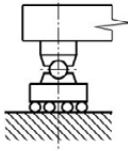


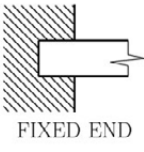

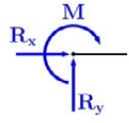



SUPPORTS	SYMBOL DRAWING	REACTIONS
 PIN CONNECTION		
 ROLLER		
 FIXED END		
 GUIDED SUPPORT		

Fig. 4.4 Basic supports

As we mentioned before in a step-by-step approach, the first step is to draw the free body diagram, where the removed supports are replaced by corresponding reactions. The four basic supports and reactions are represented in Fig. 4.4.

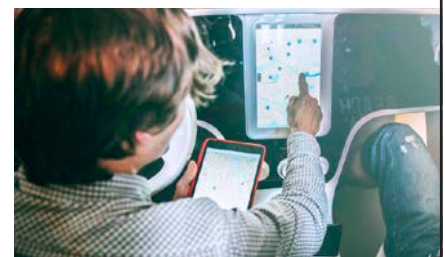
The next step in the step-by-step solution is to calculate the reactions using equilibrium equations. If the bending problem is in a plane, then the beam has three degrees of freedom (DOFs). To prevent motion of the beam, the supports must fix all three DOFs, see Fig. 4.5. Thus we obtain the equilibrium equations as follows

$$\begin{array}{ll} \Sigma F_x = 0 & \Sigma F_x = 0 \\ \Sigma F_y = 0 & \text{or} \quad \Sigma M_B = 0 \\ \Sigma M_B = 0 & \Sigma M_C = 0 \end{array} \quad (4.1)$$

**YOUR WORK AT TOMTOM WILL  
BE TOUCHED BY MILLIONS.  
AROUND THE WORLD. EVERYDAY.**

Join us now on [www.TomTom.jobs](http://www.TomTom.jobs)

follow us on **LinkedIn**



**#ACHIEVEMORE**

**TOMTOM** 

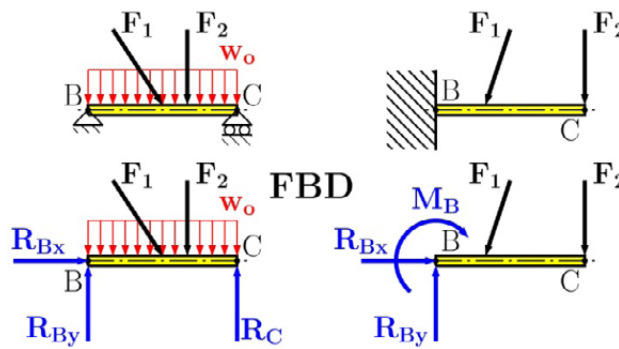


Fig. 4.5 Free-body-diagrams

### 4.3 Bending Moment and Shear Force

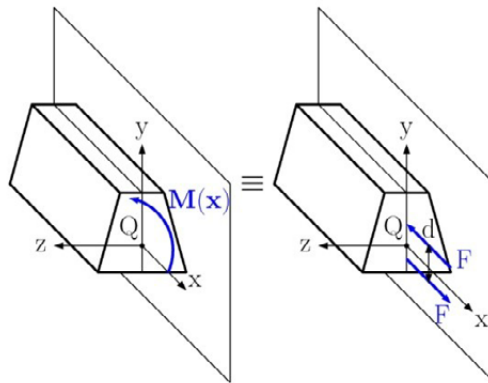


Fig. 4.6

The method of section is applied for determining the distribution functions of bending moments and shear forces. The positive orientation of shear force is explained in Section 1.2, see Fig. 1.7. The positive sign in the bending moment depends on the deformation. Let us consider only a bending moment exerted in the arbitrary section of a beam, see Fig. 4.6. This bending moment can be replaced with the moment couple  $M = Fd$ . These force systems are equivalent. The upper force  $F$  is the compressive force and the lower force  $F$  is tensile. Thus the positive bending moment causes a compression in the upper portion of the beam and simultaneously causes a tension in the lower portion of beam, see Fig. 4.7 and the negative bending moment results in an opposite beam deformation. The effects of positive and negative bending moments on beam deformations are also presented in Fig. 4.7.

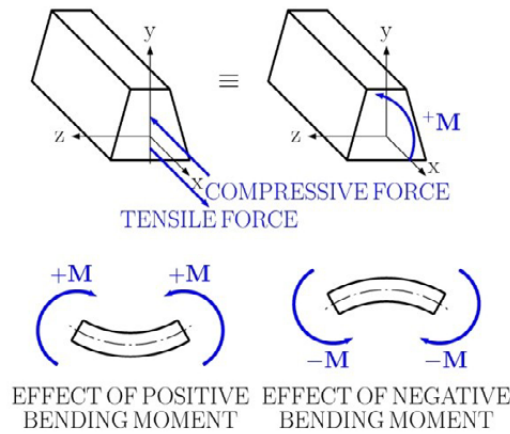


Fig. 4.7

#### 4.4 Shear and Bending Moment Diagrams

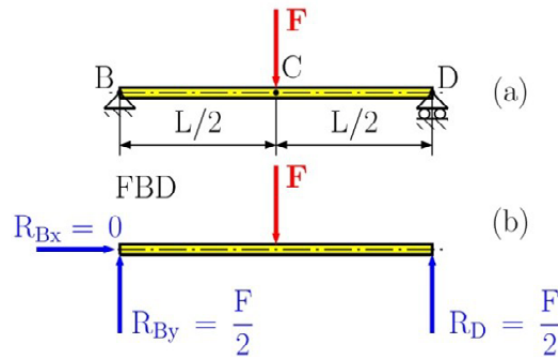


Fig. 4.8

For determining and drawing the shear force, or simple shear and bending moment diagram, we must strictly apply the step-by-step solution, for more details about this approach see Section 1.6. Let us explain the whole procedure on a simply supported beam, see Fig. 4.8(a). In this beam we have two portions, namely portion *BC* which we denote as the first and portion *CD* which we denote as the second. Drawing the free body diagram and solving the corresponding equilibrium equations we get the reactions, see Fig. 4.8(b). Then, cutting the beam at an arbitrary point *QQ* from the left side to the right one for portion *BC*, see Fig. 4.9(a) we draw this separated portion *BQ* and replace the effect of the removed part by adding positive internal forces in section *Q<sub>1</sub>Q<sub>1</sub>*, see Fig. 4.9(b) and thus get the following equilibrium equations

$$\begin{aligned}
 \sum F_V = 0 & & V_1(x_1) - R_{By} & = 0 \\
 \sum M_{Q_1} = 0 & & M_1(x_1) - R_{By}x_1 & = 0
 \end{aligned}
 \tag{4.2}$$

Solving for equations (4.2) we get

$$\begin{aligned}
 V_1(x_1) &= R_{By} = \frac{F}{2} \\
 M_1(x_1) &= R_{By}x_1 = \frac{F}{2}x_1
 \end{aligned}
 \tag{4.3}$$

Next, cutting portion  $CD$  at an arbitrary point  $Q_2$  from the right side to the left, see Fig 4.9(c), we get

$$\begin{aligned}
 \sum F_V = 0 & & V_2(x'_2) + R_D = 0 \\
 \sum M_{Q_2} = 0 & & M_2(x'_2) - R_D x'_2 = 0
 \end{aligned}
 \tag{4.4}$$

or

$$\begin{aligned}
 V_2(x'_2) &= -R_D = -\frac{F}{2} \\
 M_2(x'_2) &= R_D x'_2 = \frac{F}{2}x'_2
 \end{aligned}
 \tag{4.5}$$

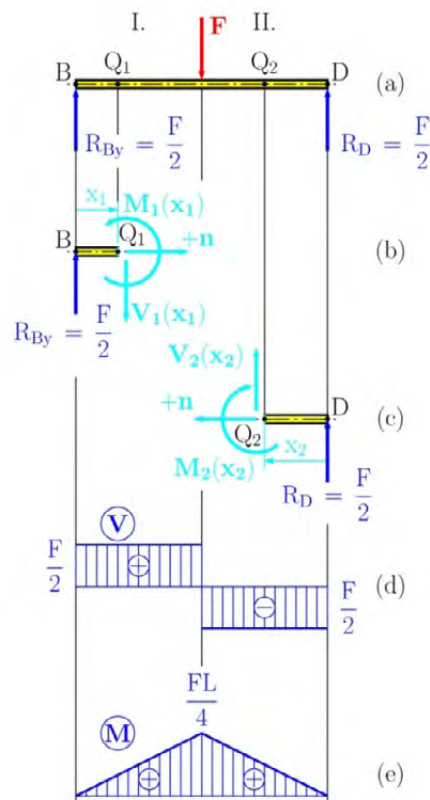


Fig. 4.9

Then we can draw the shear and bending moment diagrams, see Fig. 4.9(d) for the shear force and for the bending moment, Fig. 4.9(e).

A great disadvantage when using the above mentioned approach is the use of two functions for the shear forces and two functions for the bending moments. Considering the beam with ten different portions, then we will get ten different functions for the given variables! To overcome this inconvenience, we can apply singularity functions for determining the shear and bending moment diagrams. The use of singularity functions makes it possible to represent the shear  $V$  and the bending moment  $M$  by a single mathematical expression. Lets again consider the previous problem of the simply supported beam, see Fig. 4.8. Instead of applying two cuts in opposite directions we will now assume the same direction for both cuts. Thus we get the following shear and bending moment functions

$$V_1(x) = R_{By} = \frac{F}{2}$$

$$M_1(x) = R_{By}x = \frac{F}{2}x \quad \text{for } 0 \leq x \leq L/2 \quad (4.6)$$

and

$$V_2(x) = R_{By} - F = \frac{F}{2} - F = \frac{F}{2} - F \left(x - \frac{L}{2}\right)^0$$

$$M_2(x) = R_{By}x - F \left(x - \frac{L}{2}\right) = \frac{F}{2}x - F \left(x - \frac{L}{2}\right)^1 \quad \text{for } L/2 \leq x \leq L \quad (4.7)$$



**Brain power**

By 2020, wind could provide one-tenth of our planet's electricity needs. Already today, SKF's innovative know-how is crucial to running a large proportion of the world's wind turbines.

Up to 25 % of the generating costs relate to maintenance. These can be reduced dramatically thanks to our systems for on-line condition monitoring and automatic lubrication. We help make it more economical to create cleaner, cheaper energy out of thin air.

By sharing our experience, expertise, and creativity, industries can boost performance beyond expectations. Therefore we need the best employees who can meet this challenge!

The Power of Knowledge Engineering

Plug into The Power of Knowledge Engineering.  
Visit us at [www.skf.com/knowledge](http://www.skf.com/knowledge)

**SKF**

By simple comparison of equations (4.6) and (4.7) the presented functions can be expressed by the following representations

$$\begin{aligned} V(x) &= \frac{F}{2} - F \langle x - \frac{L}{2} \rangle^0 \\ M(x) &= \frac{F}{2} x - F \langle x - \frac{L}{2} \rangle^1 \end{aligned} \quad (4.8)$$

and we specify, that the second term in the above equation will be included into our computation if  $x \geq L/2$ , and ignored if  $x < L/2$ . In other words, *the brackets  $\langle \ \rangle$  should be replaced by ordinary parentheses  $( \ )$  when  $x \geq L/2$  and by zero if  $x < L/2$ .*

The functions  $\langle x - \frac{L}{2} \rangle^0$ ,  $\langle x - \frac{L}{2} \rangle^1$  are called *the singularity function* and by their definition we have

$$\langle x - a \rangle^n = \begin{cases} 0 & \text{when } x < a \\ (x - a)^n & \text{when } x \geq a \end{cases} \quad (4.9)$$

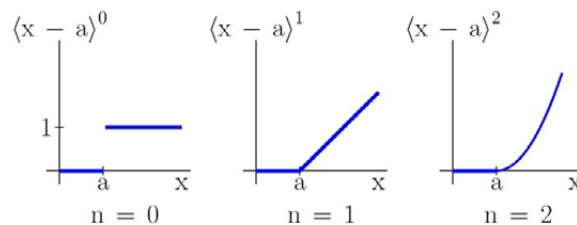


Fig. 4.10

The graphical representation of the constant, linear and quadratic functions are presented in Fig. 4.10. The basic mathematical operations with singularity functions, such as integrations and derivations, are exactly the same as with ordinary parenthesis, i.e.

$$\begin{aligned} \int \langle x - a \rangle^n dx &= \frac{1}{n+1} \langle x - a \rangle^{n+1} \\ \frac{d}{dx} \langle x - a \rangle^n &= n \langle x - a \rangle^{n-1} \end{aligned} \quad (4.10)$$

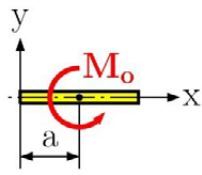
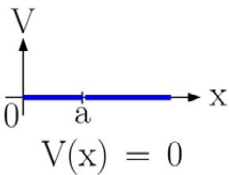
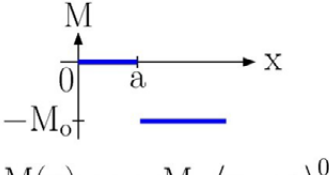
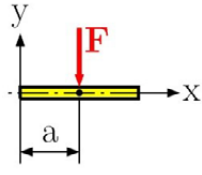
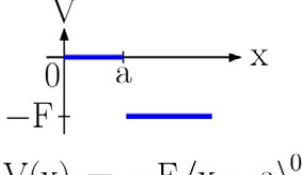
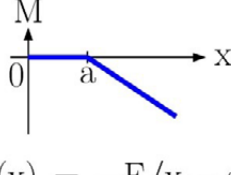
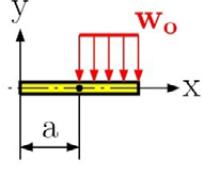
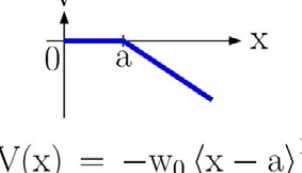
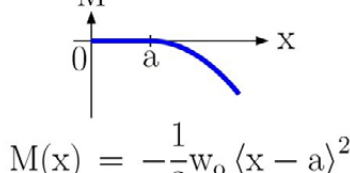
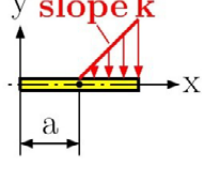
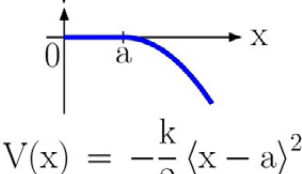
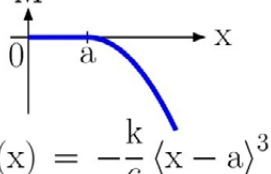
LOADING	SHEAR	BENDING MOMENT
	 $V(x) = 0$	 $M(x) = -M_o \langle x - a \rangle^0$
	 $V(x) = -F \langle x - a \rangle^0$	 $M(x) = -F \langle x - a \rangle^1$
	 $V(x) = -w_0 \langle x - a \rangle^1$	 $M(x) = -\frac{1}{2} w_0 \langle x - a \rangle^2$
	 $V(x) = -\frac{k}{2} \langle x - a \rangle^2$	 $M(x) = -\frac{k}{6} \langle x - a \rangle^3$

Fig. 4.11

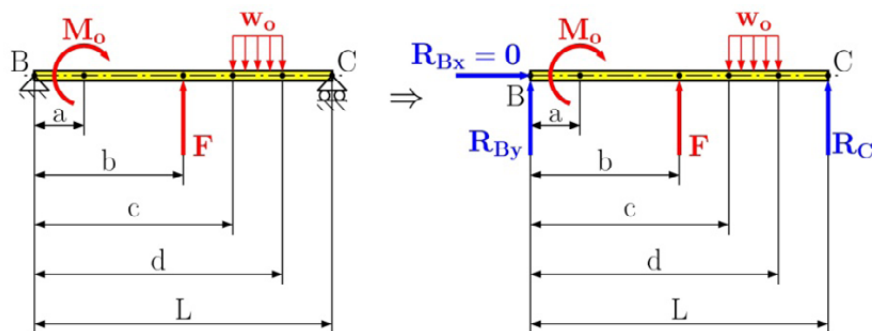


Fig. 4.12

Now when the beam is subjected to several loads, we can then divide them into individual basic loads using the principle of superposition. Thus the shear and bending moment at any point of the beam can be obtained by adding up the corresponding functions associated with each of the basic loads and reactions. The singularity functions for simple loads are represented in Fig. 4.11.

In the following problem Fig. 4.12, an illustrative application of the singularity functions can be seen. Our task is to find the distribution functions of shear and bending moment. At first we divide the applied load into basic loads according to Fig. 4.11 and then apply the principle of superposition to get

$$V(x) = R_{By} \langle x - 0 \rangle^0 + F \langle x - b \rangle^0 - w_0 \langle x - c \rangle^1 + w_0 \langle x - d \rangle^1$$

$$M(x) = R_{By} \langle x - 0 \rangle^1 + M_0 \langle x - a \rangle^0 + F \langle x - b \rangle^1 - \frac{1}{2} w_0 \langle x - c \rangle^2 + \frac{1}{2} w_0 \langle x - d \rangle^2$$

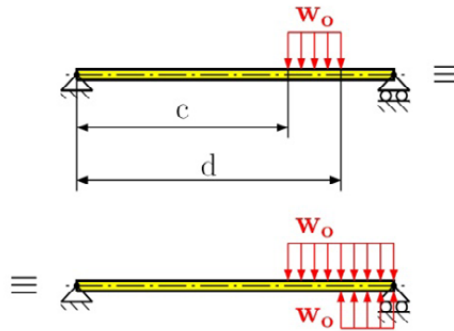


Fig. 4.13

The last two terms in the above equations represent the distributed load that does not finish at the end of beam as the corresponding singularity function assumes. The presented function in Fig. 4.11 is the open-ended one. Therefore we must modify it by adding two equivalent open-ended loadings. To clarify this statement, see Fig. 4.13.

#### 4.5 Relations among Load, Shear, and the Bending Moment

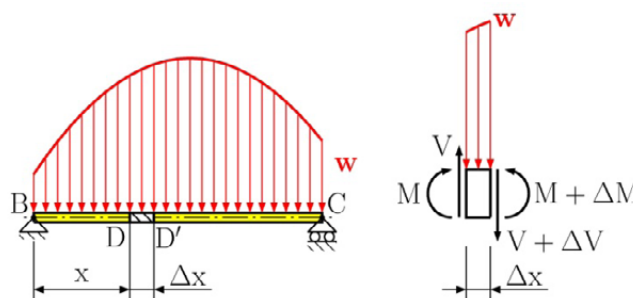


Fig. 4.14

Sometimes the determination of internal forces may be cumbersome when several different types of loading are applied on to the beam. This can be greatly facilitated if some relations between load, shear, and bending moment exist. Therefore, let us now consider the simply supported straight beam subjected to a distributed load  $w$ , see Fig. 4.14. We detach portion  $DD'$  of the beam by two parallel sections and draw the free body diagram of the detached portion. The effects of the removed parts are replaced by internal forces at both points, namely the bending moment  $M$  and the shear force  $V$  at  $D$ , and the bending moment  $M + \Delta M$  and the shear force  $V + \Delta V$  at  $D'$ . This detached portion has to be in equilibrium, then we can write the equilibrium equations as follows

$$\begin{aligned}\sum F_{V+\Delta V} = 0 & \quad (V + \Delta V) - V + w\Delta x = 0 \\ \sum M_{D'} = 0 & \quad (M + \Delta M) - M + w\frac{\Delta x^2}{2} - V\Delta x = 0\end{aligned}\quad (4.11)$$

after some mathematical manipulations we get

$$\begin{aligned}\Delta V = -w\Delta x & \quad \text{or} \quad \frac{\Delta V}{\Delta x} = -w \\ \Delta M = V\Delta x - w\frac{\Delta x^2}{2} & \quad \text{or} \quad \frac{\Delta M}{\Delta x} = V - w\frac{\Delta x}{2}\end{aligned}\quad (4.12)$$



**> Apply now**

REDEFINE YOUR FUTURE  
**AXA GLOBAL GRADUATE  
PROGRAM 2015**

redefining / standards 

agence.cdg. © Photonistop

approaching  $\Delta x$  to zero, we get

$$\begin{aligned}\frac{dV}{dx} &= -w \\ \frac{dM}{dx} &= V\end{aligned}\quad (4.13)$$

These relations between the applied load, shear force, and bending moment are known as *Zhuravsky's theorem* (D.I. Zhuravsky, 19<sup>th</sup> century). We should also note that the sections were made from the left to the right side. If we make the sections in the opposite direction, the results will have the opposite sign. Therefore the complete Zhuravsky theorem can be stated as follows

$$\begin{aligned}\frac{dV}{dx} &= \mp w \\ \frac{dM}{dx} &= \pm V\end{aligned}\quad (4.14)$$

#### 4.6 Definition of Normal and Shearing Stresses

Let us consider the cantilever beam  $BC$  subjected to an applied force at its free end, see Fig. 4.15. Applying the step-by-step solution, we get the shear function and bending moment function as  $V(x) = F$  and  $M(x) = Fx$  respectively. These two functions represent the combined load on the cantilever beam. The bending moment  $M(x)$  represents the effect of the normal stresses in the cross-section, while the shear force  $V(x)$  represents the effect of the shearing stresses. This allows us to simplify the determination of the normal stresses for pure bending. This is a special case when the whole beam, or its portion, is exerted on by only the bending moment, see the examples in Fig. 4.16.

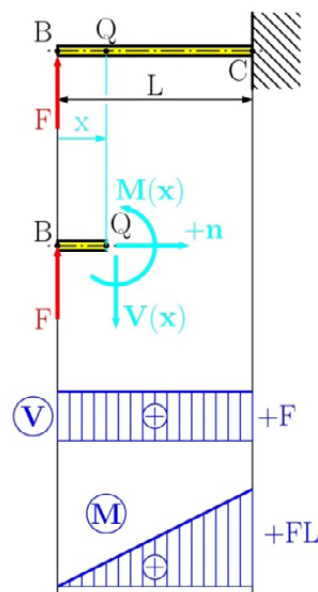


Fig. 4.15

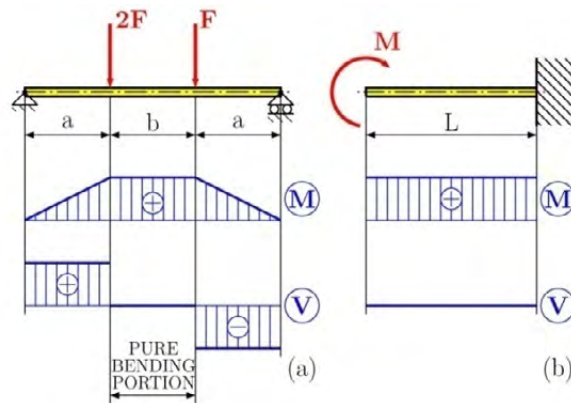


Fig. 4.16

Firstly, let us consider the effect of the pure bending moment  $M(x)$ . Let us consider the cantilever beam with a length  $L$  subjected to the moment couple  $M$ , see Fig. 4.16(b). The corresponding bending moment  $M(x) = M$  obtained by the method of section. This bending moment represents the resultant of all elementary forces acting on this section, see Fig. 4.17. For simplicity the bending moment considered is positive. Both force systems are equivalent, therefore we can write the equivalence equations

## LIGS University

based in Hawaii, USA

is currently enrolling in the  
Interactive Online **BBA, MBA, MSc,**  
**DBA and PhD** programs:

- ▶ enroll **by October 31st, 2014** and
- ▶ **save up to 11%** on the tuition!
- ▶ pay in 10 installments / 2 years
- ▶ Interactive **Online** education
- ▶ visit [www.ligsuniversity.com](http://www.ligsuniversity.com) to find out more!

Note: LIGS University is not accredited by any nationally recognized accrediting agency listed by the US Secretary of Education. More info [here](http://www.ligsuniversity.com).



$$\begin{aligned}
 \sum F_x &= 0 & \int \sigma_x dA &= 0 \\
 \sum M_y &= 0 & \text{or} & \int z \sigma_x dA = 0 \\
 \sum M_z &= M(x) & \int -y \sigma_x dA &= M(x)
 \end{aligned}
 \tag{4.15}$$

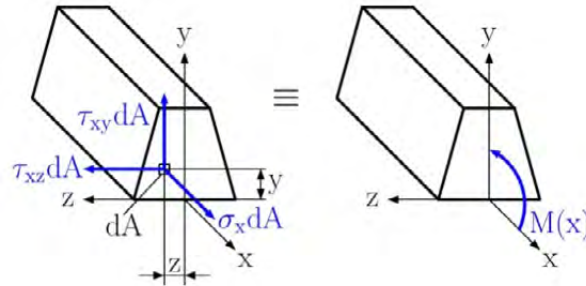


Fig. 4.17

The rest of the equivalence equations can be obtained by setting the sum of the  $y$  components,  $z$  components, and moments about the  $x$  axis to be equal to zero. But these equations would involve only the components of shearing stress and the components of the shearing stress are both equal to zero! As one can see, the determination of the normal stress is a statically indeterminate problem. Therefore it can be obtained only by analysing the deformation of the beam.

Let us analyse the deformation of the prismatic straight beam subjected to pure bending applied in the plane of symmetry, see Fig 4.18. The beam will bend uniformly under the action of the couples  $M$  and  $M'$ , but it will remain symmetric with respect to the plane of symmetry. Therefore each straight line of undeformed beam is transformed into the curve with constant curvature, i.e. into a circle with a common centre at  $C$ . The deformation analysis of the symmetric beam is based on the following assumptions proven by experiments:

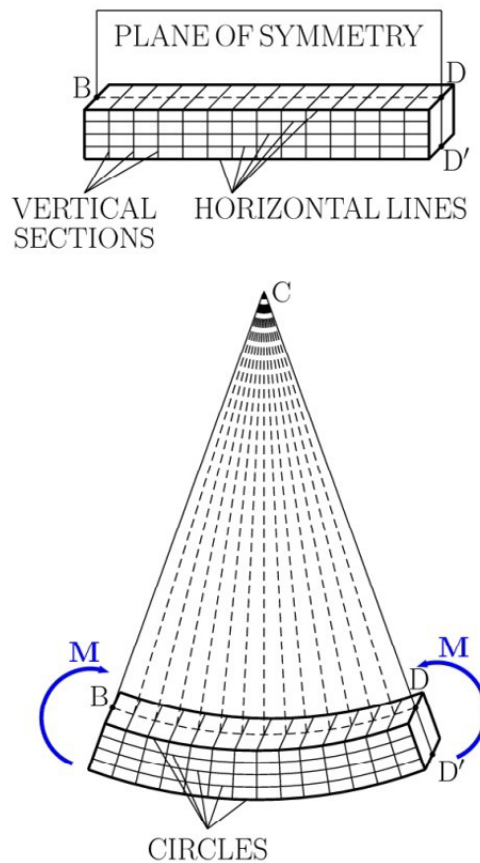


Fig. 4.18

- transverse sections remain plane after deformation and these sections pass through a common point at C;
- due to uniform deformation, the horizontal lines are either extended or contracted;
- the deformations of lines are not depend on their positions along the width of the cross-section, i.e. the stress distribution functions along the cross-sectional width are uniform;
- the material behaviour is linear and elastic, satisfying Hooke law, having the same response in tension and compression.

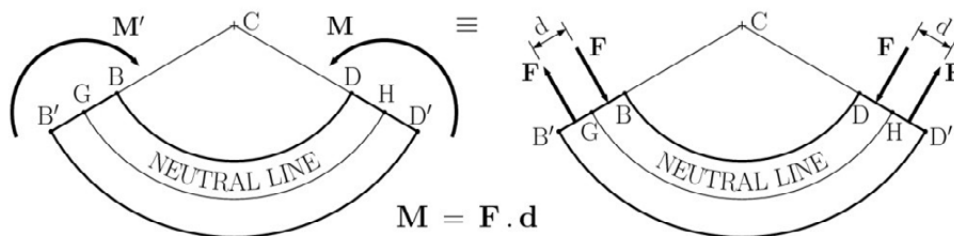


Fig. 4.19

Since the vertical sections are perpendicular to the circles after deformation, we can then conclude that  $\gamma_{xy} = \gamma_{xz} = 0$  and  $\tau_{xy} = \tau_{xz} = 0$ . Subsequently, due to the uniform deformations along the cross-sectional width, we get  $\sigma_y = \sigma_z = 0$  and  $\tau_{yz} = 0$ . Then, at any point of a member in pure bending, only the normal stress component  $\sigma_x$  is exerted. Therefore at any point of a member in pure bending, we have a uniaxial stress state. Recalling that, for  $M = Fd > 0$ , lines  $BD$  and  $B'D'$  decrease and increase in length, we note that the normal strain  $\epsilon_x$  and the corresponding normal stress  $\sigma_x$  are negative in the upper portion of the member (compression) and positive in the lower portion (tension), see Fig. 4.19.

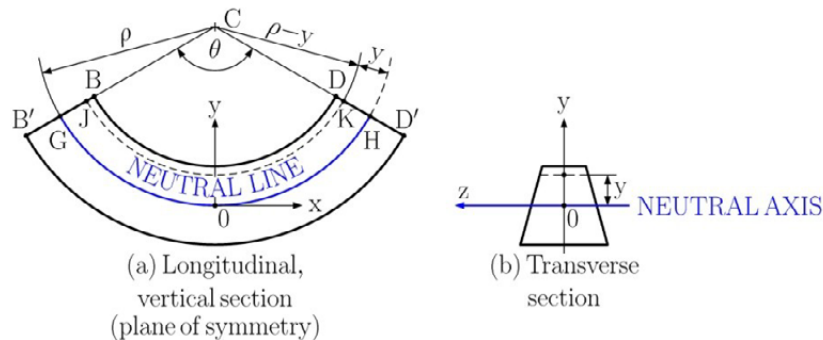


Fig. 4.20

## TURN TO THE EXPERTS FOR SUBSCRIPTION CONSULTANCY

Subscribe is one of the leading companies in Europe when it comes to innovation and business development within subscription businesses.

We innovate new subscription business models or improve existing ones. We do business reviews of existing subscription businesses and we develop acquisition and retention strategies.

Learn more at [linkedin.com/company/subscribe](https://www.linkedin.com/company/subscribe) or contact Managing Director Morten Suhr Hansen at [mha@subscribe.dk](mailto:mha@subscribe.dk)

**SUBSCR**✓**IBE** - to the future

From the above it follows that there must exist a *neutral line* (N.L.) with zero values of  $\sigma_x$  and  $\varepsilon_x$ . This neutral line represents the *neutral surface* (N.S) due to the uniform deformations along the cross-sectional width. The neutral surface intersects the plane of symmetry along the circular arc of  $GH$ , see Fig. 4.20(a), and intersects the transverse section along the straight line known as *the neutral axis* (N.A.), see Fig 4.20(b).

Denoting the radius of the neutral arc  $GH$  by  $\rho$ ,  $\theta$  becomes the central angle corresponding to  $GH$ . Observing that the initial length  $L$  of the undeformed member is equal to the deformed arc  $GH$ , we have

$$L = \rho\theta \quad (4.16)$$

now consider the arc  $JK$  located at a distance  $y$  from the neutral surface, the length  $L'$  can be expressed as follows

$$L' = (\rho - y)\theta \quad (4.17)$$

Since the initial length of the arc  $JK$  is equal to  $L$ , then its deformation is

$$\Delta L = L' - L = (\rho - y)\theta - \rho\theta = -y\theta \quad (4.18)$$

and we can calculate the longitudinal strain  $\varepsilon_x$  as follows

$$\varepsilon_x = \frac{\Delta L}{L} = \frac{-y\theta}{\rho\theta} = -\frac{y}{\rho} \quad (4.19)$$

The negative sign is due to the fact that we have assumed the bending moment to be positive and thus, the beam to be concave upward. We can now conclude that the longitudinal strain  $\varepsilon_x$  varies linearly with distance from the neutral surface. It is only natural that the strain  $\varepsilon_x$  reaches its absolute maximum value at the furthest distance from the neutral surface  $y_{max}$ , thus we get

$$\varepsilon_{max} = \frac{y_{max}}{\rho} \quad (4.20)$$

Solving equation (4.20) for  $\rho$  and substituting into equation (4.19) we obtain

$$\varepsilon_x = -\frac{y}{y_{max}} \varepsilon_{max} \quad (4.21)$$

This result is only qualitative though, due to the fact that, until now, we have not located the neutral surface or neutral axis. On the other hand, we can determine the normal stress distribution function along the vertical axis  $y$  so we can multiply equation (4.21) by Young's modulus  $E$ , since we are considering the linear elastic response, thus

$$E\varepsilon_x = -\frac{y}{y_{max}} E\varepsilon_{max} \quad \text{or} \quad \sigma_x = -\frac{y}{y_{max}} \sigma_{max} \quad (4.22)$$

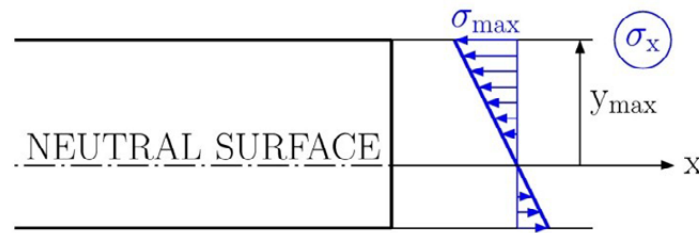


Fig. 4.21

This result shows that, in the elastic region, the normal stress varies linearly with the distance from the neutral surface as well, see Fig. 4.21.

But still the location of the neutral surface and the maximum absolute value  $\sigma_{max}$  are unknown! Therefore we recall equations (4.15) and substitute for  $\sigma_x$  into the first relation and get

$$\int \sigma_x dA = \int -\frac{y}{y_{max}} \sigma_{max} dA = -\frac{\sigma_{max}}{y_{max}} \int y dA = 0 \quad (4.23)$$

From which it follows that

$$\int y dA = 0 \quad (4.24)$$

The last equation shows that the first moment must be equal zero, or in the sense of statics, that the neutral axis passes through the centre of the cross-section.

Now we can recall the third equation in (4.15), after substituting for  $\sigma_x$  we obtain

$$\int -y \sigma_x dA = \int -y \left( -\frac{y}{y_{max}} \sigma_{max} \right) dA = \frac{\sigma_{max}}{y_{max}} \int y^2 dA = M(x) \quad (4.25)$$

The integral  $\int y^2 dA$  represents the moment of inertia, or the second moment of the cross-section with respect to the neutral axis, that coincides with the  $z$  axis. For more details about moments of inertia, see Appendix A. Denoting the moment of inertia by  $I$ , we have

$$M(x) = \frac{\sigma_{max}}{y_{max}} I \quad \text{or} \quad \sigma_{max} = \frac{M(x)}{I} y_{max} \quad (4.26)$$

After substituting for  $\sigma_{max}$  we can obtain the formula for normal stress  $\sigma_x$  at any distance from the neutral axis as follows

$$\sigma_x = -\frac{M(x)}{I} y \quad (4.27)$$

Returning to equation (4.26), the ratio  $I/y_{max}$  depends upon the geometry of the cross-section, thus this can be any other cross-sectional characteristic which is known as *the section modulus*  $S$

$$S = \frac{I}{y_{max}} \quad (4.28)$$

Substituting for the section modulus  $S$  into equation (4.26) we get

$$\sigma_{max} = \frac{M(x)}{S} \quad (4.29)$$

Finally we return to the second equation in (4.15) and substitute for  $\sigma_x$ , to obtain

$$\int z \sigma_x dA = \int z \left( -\frac{y}{y_{max}} \sigma_{max} \right) dA = -\frac{\sigma_{max}}{y_{max}} \int yz dA = 0 \quad (4.30)$$

From which it follows that

$$\int yz dA = 0 \quad (4.31)$$

The above equation represents *the product of inertia* and it must be equal to zero. This means that the neutral axis ( $z$  axis) and  $y$  axis are *principal axes of inertia*, for more details see Appendix A.

The deformation of a member as a result of a bending moment  $M(x)$  is usually measured by *the curvature* of the neutral surface. From mathematics the curvature is reciprocal to the radius of curvature  $\rho$ , and it can be derived from equation (4.20) as follows

$$\frac{1}{\rho} = \frac{\varepsilon_{max}}{y_{max}} \quad (4.32)$$

Recalling Hooke law  $\varepsilon_{max} = \frac{\sigma_{max}}{E}$  and equation (4.26) we get

$$\frac{1}{\rho} = \frac{\sigma_{max}}{Ey_{max}} = \frac{1}{Ey_{max}} \frac{M(x)}{I} y_{max} = \frac{M(x)}{EI} \quad (4.33)$$

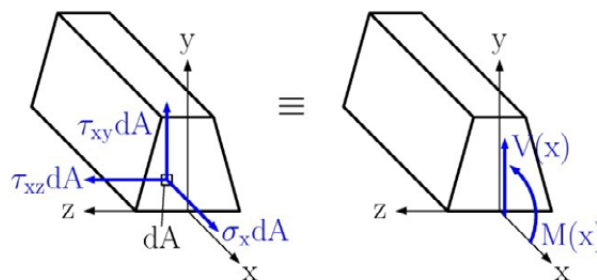


Fig. 4.22

Secondly, let us consider the effect of the shear force  $V(x)$ . As we mentioned before, the shear force  $V(x)$  represents the effect of the shearing stresses in the section. Let us consider the transversally loaded cantilever beam with a vertical plane of symmetry from Fig. 4.15. Fig. 4.22 graphically represents the distributions of elementary normal and shear forces on any arbitrary section of the cantilever beam. These elementary forces are equivalent to the bending moment  $M(x) = Fx$  and the shear force  $V(x) = F$ . Both systems of forces are equivalent, therefore we can write the equations of equivalence. Three of them involve the normal force  $\sigma_x dA$  only and have already been discussed in the previous subsection, see equations (4.15). Three more equations involving the shearing forces  $\tau_{xy} dA$  and  $\tau_{xz} dA$  can now be written. But one of them expresses that the sum of moments about the  $x$  axis is equal to zero and it can be dismissed due to the symmetry with respect of the  $xy$  plane. Thus we have

$$\begin{aligned} \sum F_y = 0 & \quad \text{or} \quad \int \tau_{xy} dA = -V(x) \\ \sum F_z = 0 & \quad \text{or} \quad \int \tau_{xz} dA = 0 \end{aligned} \quad (4.34)$$

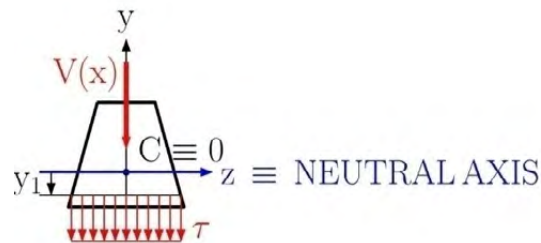


Fig. 4.23

"I studied English for 16 years but...  
...I finally learned to speak it in just six lessons"

Jane, Chinese architect

ENGLISH OUT THERE

Click to hear me talking before and after my unique course download

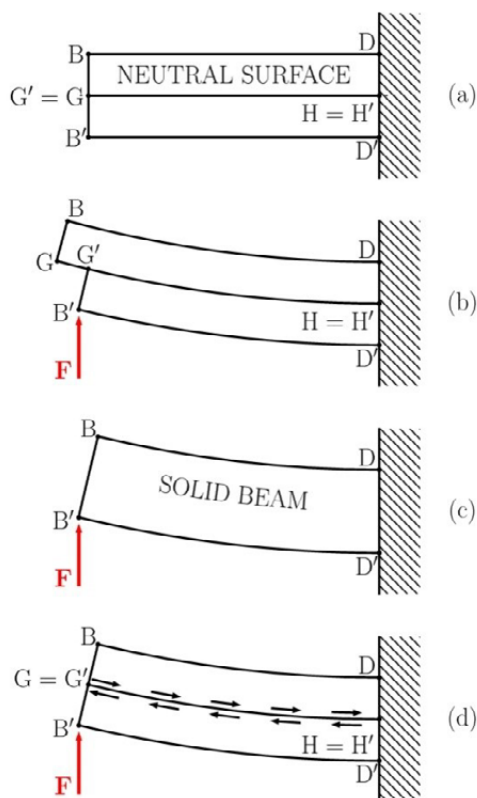


Fig. 4.24

The first equation above indicates that the shearing stress must exist in the transverse section. The second equation shows that the average value of the horizontal shearing stress  $\tau_{xz}$  is equal to zero. But this statement does not mean that the shearing stress  $\tau_{xz}$  is zero everywhere. Again as one can see, the determination of the shearing stress is a statically indeterminate problem. The following assumptions about the distribution of the shearing stress have been formulated by *Zhuravsky*:

- the direction of shearing stresses are parallel to the shear force;
- the shearing stresses acting on the surface at the distance  $y_1$  from the neutral surface are uniform, see Fig. 4.23.

The existence of shearing can be proven by the shear law. Let us build our cantilever beam from two portions that are clamped together, see Fig. 4.24(a). The cantilever beam is divided into two portions at the neutral surface  $GH$ . After applying a load  $F$  each portion will slide with respect to each other, see Fig. 4.24(b). In contrast, the free end of the solid cantilever beam is smooth after the deformation; see Fig. 4.24(c). To obtain the same response, i.e. the smooth end for the clamped cantilever beam, we must insert additional forces between portions to conserve the constant length of both arches  $GH$  and  $G'H'$ ; see Fig. 4.24(d). This represents the existence of shearing stresses on the neutral surface and the perpendicular cross-section (along the neutral axis).

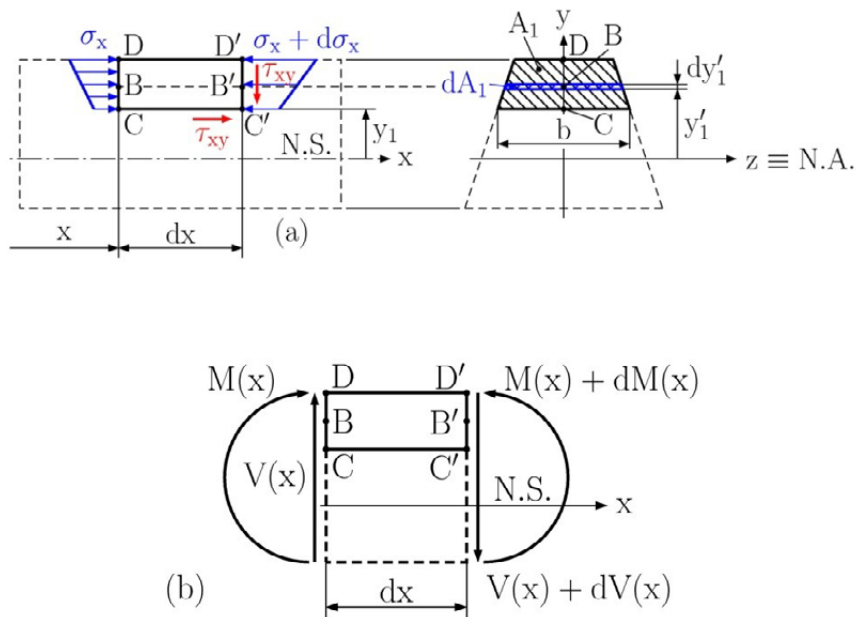


Fig. 4.25

For determining the shearing stress at a distance  $y_1$  from the neutral surface, we can detach a small portion  $C'D'DC$  with length  $dx$  at the distance  $xx$  from the free end of the cantilever beam, see Fig. 4.25. The width of the detached portion at the vertical distance  $y_1$  is denoted by  $b$ . Thus we can write the equilibrium equation in the  $x$  direction for the detached portions as follows

$$\sum F_x = 0 \quad - \int (\sigma_x + d\sigma_x) dA_1 + \int \sigma_x dA_1 + \tau_{xy} b dx = 0 \tag{4.35}$$

The normal stress at point  $B$  can be expressed by  $\sigma_x = -\frac{M(x)}{I_z} y_1'$  and its increment at point  $B'$  can be expressed as  $d\sigma_x = -\frac{dM(x)}{I_z} y_1'$ , see Fig. 4.25(b), after substituting into equation (4.35) we have

$$- \int \frac{dM(x)}{I_z} y_1' dA_1 = \tau_{xy} b dx \tag{4.36}$$

subsequently we can now get the shearing stress  $\tau_{xy}$  at the distance  $y_1$  from the neutral axis

$$\tau_{xy} = -\frac{dM(x)}{dx} \frac{1}{b I_z} \int y_1' dA_1 \tag{4.37}$$

or

$$\tau_{xy} = -\frac{V(x) Q_z}{b I_z} \tag{4.38}$$

The shear force is determined by the Zhuravsky theorem, i.e.  $V(x) = \frac{dM(x)}{dx}$ , and the first moment of the face  $CD'$  is calculated by  $Q_z = \int y'_1 dA_1$ . The negative sign in the above equations represents the opposite orientation of the positive shear force on the face  $CD'$  to the orientation of the  $y$  axis. Thus satisfying our positive definition of the shear force we can write

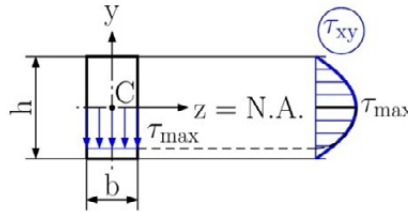


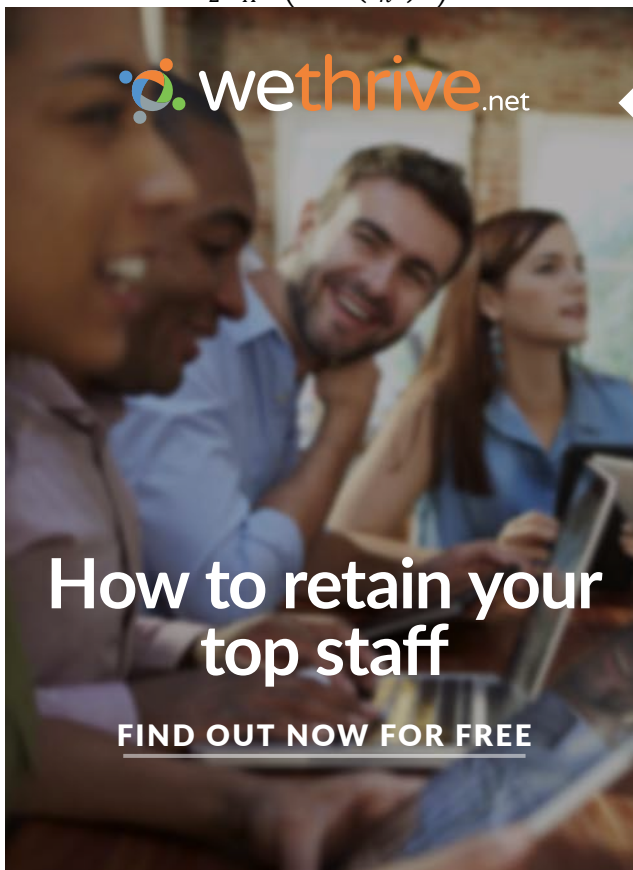
Fig. 4.26

$\tau_{xy} = \frac{V(x)Q_z}{bI_z}$  (4.39) For the rectangular cross-section of the beam with the dimensions  $b \times h$ , see Fig. 4.26, we have




$$Q_z = \int y'_1 dA_1 = \int_{y'_1}^{\frac{h}{2}} y'_1 b dy'_1 = \frac{b}{2} \left( \frac{h^2}{4} - y_1^2 \right) \tag{4.40}$$

knowing that  $I_z = \frac{1}{12}bh^3$  we can finally formulate the shearing stress distribution function

$$\tau_{xy} = \frac{3V(x)}{2A} \left( 1 - \left( \frac{2y_1}{h} \right)^2 \right) \tag{4.41}$$

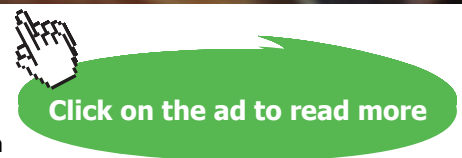


**DO YOU WANT TO KNOW:**

-  What your staff really want?
-  The top issues troubling them?
-  How to make staff assessments work for you & them, painlessly?

Get your free trial

Because happy staff get more done



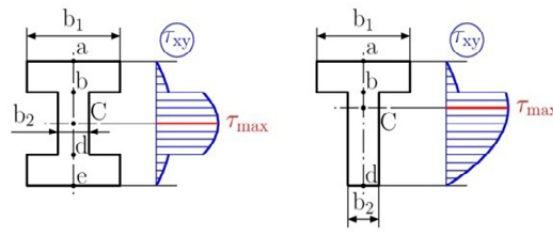


Fig. 4.27

This equation represents a parabolic distribution of the shearing stresses along the vertical axis with zero values at the top and bottom. The maximum value of the shearing stress, i.e.  $\tau_{max} = \frac{3}{2} \frac{V(x)}{A}$ , is at the neutral surface, see Fig. 4.26.

If we apply equations (4.39) for determining the distribution of shearing stresses  $\tau_{xy}$  along the vertical axis  $y$  of W-beams (wide flange beam) or S-beams (standard flange beams), we will get the distribution function presented in Fig. 4.27. The discontinuity of the distribution function is caused by the jump in width at the connection of the flange to the web.

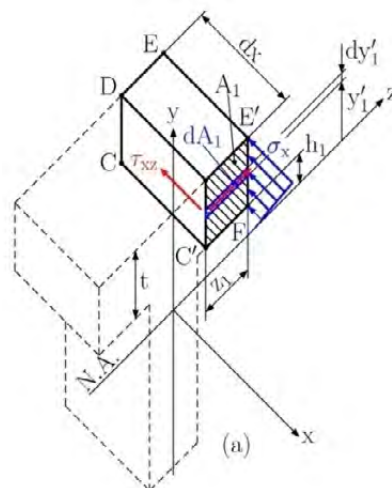


Fig. 4.28 continued

For determining the shearing stress  $\tau_{xz}$  in the flange of W-beams or S-beams we need to detach the portion  $C'D'E'F'$ , see Fig. 4.28(a). Again we can apply the above mentioned approach and we can write the equilibrium equation for the detached portion, in the  $x$  direction, as follows

$$\sum F_x = 0 \quad - \int (\sigma_x + d\sigma_x) dA_1 + \int \sigma_x dA_1 - \tau_{xz} t dx = 0 \quad (4.42)$$

Solving this equation we have

$$- \int \frac{dM(x)}{I_z} y_1' dA_1 = \tau_{xz} t dx \quad (4.43)$$

or

$$\tau_{xz} = -\frac{V(x)Q_z}{tI_z} \quad (4.44)$$

Then substituting for the first moment of the area  $C'D'E'F'$ ,  $Q_z = \int y_1' dA_1 = z_1 t \frac{h_1+t}{2}$  we get

$$\tau_{xz} = \frac{V(x)(h_1+t)}{2I_z} z_1 \quad (4.45)$$

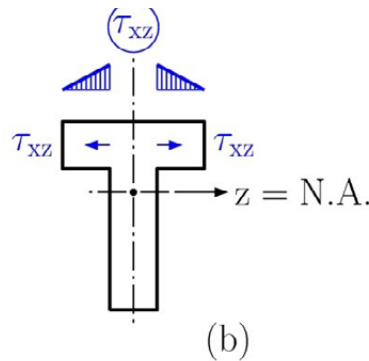


Fig. 4.28 end

This equation shows that the shearing stress  $\tau_{xz}$  is linearly dependent on the width of the detached portion, namely on  $z_1$ , see Fig. 4.28(b).

#### 4.7 Design of Straight Prismatic Beams

The design of straight prismatic beams is usually controlled by the maximum absolute value of the bending moment  $M_{max}$  in the beam. This value can be found from the bending moment diagram. The point with the absolute maximum value of bending moment  $M_{max}$  is known as *the critical point* of a beam. At the critical point the maximum normal stress can be calculated as follows

$$\sigma_{max} = \frac{M_{max}}{S} \quad \text{OR} \quad \sigma_{max} = \frac{M_{max}}{I} y_{max}$$

safe design requires that the strength condition  $\sigma_{max} \leq \sigma_{All}$  be satisfied. From this condition we can determine the minimum section modulus

$$S_{min} = \frac{M_{max}}{\sigma_{All}} \quad (4.46)$$

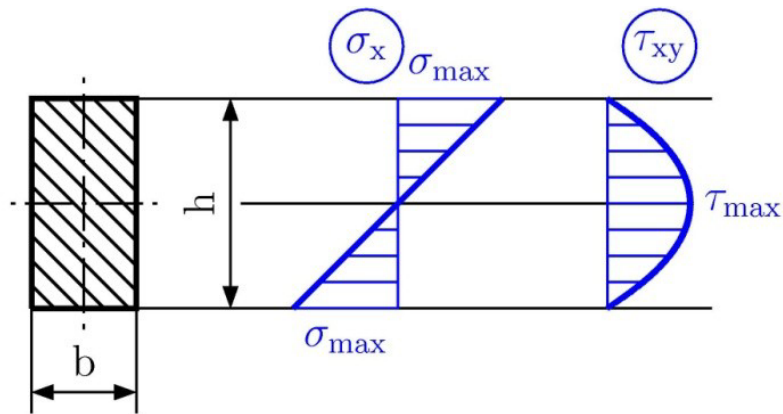


Fig. 4.29

Then we need to check our design in respect to the absolute maximum value of the shear force  $V_{max}$  obtained from the shear diagram. The reason is simple; the maximum absolute value of the normal stress is either on the top or the bottom of the section considered and the absolute value of the shearing stress is on the neutral axis, see Fig. 4.29. Therefore the shear strength condition  $\tau_{max} \leq \tau_{All}$  must be satisfied, where

$$\tau_{max} = \frac{V_{max} Q_z}{b I_z} \leq \tau_{All} \tag{4.47}$$

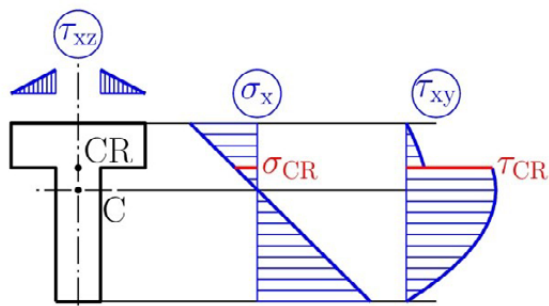


Fig. 4.30

The last step is more complicated, mainly for W-beams. If we draw the distribution functions of the normal and shearing stresses, see Fig. 4.30, the critical point will be at the connection between the flange and the web. At point CR, combined loading exists with relatively high values of both stresses. Therefore we need to discuss *the strength criterion of combined loading*.

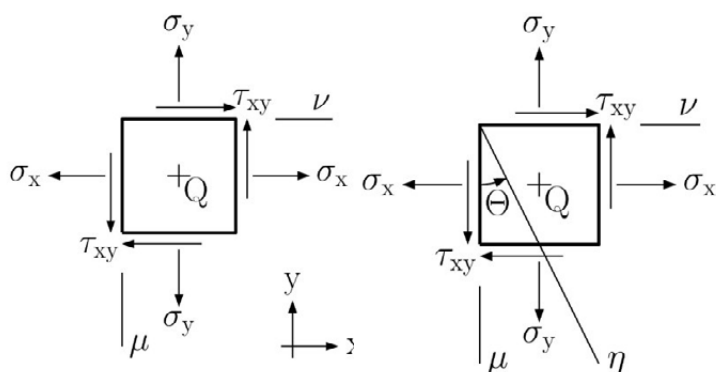


Fig. 4.31

Fig. 3.32

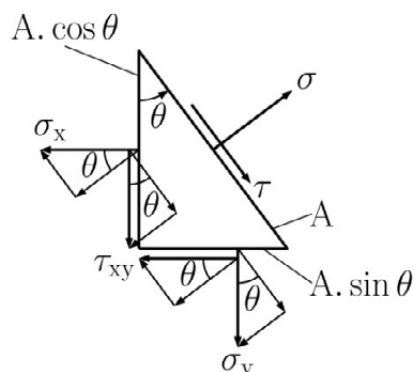


Fig. 3.33

For deriving the strength criterion of combined loading, we first have to analyse the stress transformation. For simplicity let us consider a plane stress state at any arbitrary point Q defined by two normal stresses  $\sigma_x, \sigma_y$  and one shearing component  $\tau_{xy}$ , see Fig. 4.31. The plane  $\mu$  is characterised by stress components and the plane  $\nu$  is characterised by stress components  $\sigma_y, \tau_{xy}$ . These planes correspond to the  $x, y$  coordinate system. Now our task is to determine the normal and shearing stresses at any arbitrary plane  $\eta$ , see Fig. 4.32. Making a section by plane  $\eta$  we get the triangle from the unit square, see Fig. 4.33. This triangle must also be in equilibrium and by inserting the normal stress  $\sigma$  and the shearing stress  $\tau$  into the plane  $\eta$  we can write the equilibrium equations

$$\begin{aligned}
 \sum F_o = 0 \quad & \sigma A - \sigma_x \cos \theta A \cos \theta - \sigma_y \sin \theta A \sin \theta - \tau_{xy} \sin \theta A \cos \theta - \\
 & - \tau_{xy} \cos \theta A \sin \theta = 0 \\
 \sum F_t = 0 \quad & \tau A - \sigma_x \sin \theta A \cos \theta + \sigma_y \cos \theta A \sin \theta + \tau_{xy} \cos \theta A \cos \theta - \\
 & - \tau_{xy} \sin \theta A \sin \theta = 0
 \end{aligned}
 \tag{4.48}$$

After some mathematical manipulation we obtain

$$\begin{aligned}\sigma &= \sigma_x \cos^2 \theta + \sigma_y \sin^2 \theta + 2\tau_{xy} \cos \theta \sin \theta \\ \tau &= \sigma_x \cos \theta \sin \theta - \sigma_y \cos \theta \sin \theta + \tau_{xy} \sin^2 \theta - \tau_{xy} \cos^2 \theta\end{aligned}\quad (4.48)$$

Applying the following relations

$$\cos^2 \theta = \frac{1 + \cos 2\theta}{2}, \quad \sin^2 \theta = \frac{1 - \cos 2\theta}{2}, \quad 2 \cos \theta \sin \theta = \sin 2\theta$$

we have

$$\begin{aligned}\sigma &= \frac{\sigma_x + \sigma_y}{2} + \frac{\sigma_x - \sigma_y}{2} \cos 2\theta + \tau_{xy} \sin 2\theta \\ \tau &= \frac{\sigma_x - \sigma_y}{2} \sin 2\theta - \tau_{xy} \cos 2\theta\end{aligned}\quad (4.50)$$

These equations show that the stress transformation depends upon the angle  $\theta$  and are independent to the material properties. Let us modify equations (4.50) to give

$$\begin{aligned}\sigma - \frac{\sigma_x + \sigma_y}{2} &= \frac{\sigma_x - \sigma_y}{2} \cos 2\theta + \tau_{xy} \sin 2\theta \\ \tau &= \frac{\sigma_x - \sigma_y}{2} \sin 2\theta - \tau_{xy} \cos 2\theta\end{aligned}\quad (4.51)$$

Squaring both equations and then adding them together we get

$$\left(\sigma - \frac{\sigma_x + \sigma_y}{2}\right)^2 + \tau^2 = \left(\frac{\sigma_x - \sigma_y}{2}\right)^2 + \tau_{xy}^2\quad (4.52)$$

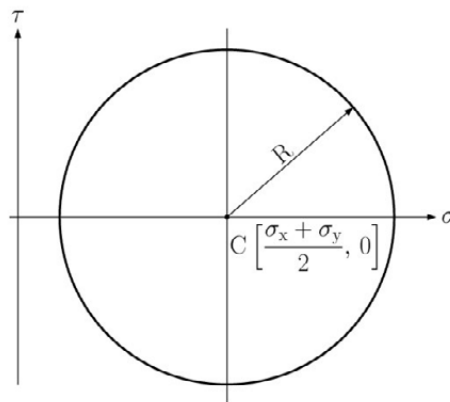


Fig. 4.34

The above equation represents a circle defined by its centre at  $\left[\frac{\sigma_x + \sigma_y}{2}, 0\right]$  and with a radius of  $R = \sqrt{\left(\frac{\sigma_x - \sigma_y}{2}\right)^2 + \tau_{xy}^2}$  in the space of  $\sigma$ ,  $\tau$ . This circle is the well-known *Mohr's circle*. The graphical representation of Mohr's circle is presented in Fig. 4.34. The physical meaning of Mohr's circle is that each point of this circle represents a plane characterised by the stresses  $\sigma$ ,  $\tau$ . Denoting the average stress as  $\sigma_{ave} = \frac{\sigma_x + \sigma_y}{2}$  we get

$$(\sigma - \sigma_{ave})^2 + \tau^2 = R^2 \quad (4.53)$$

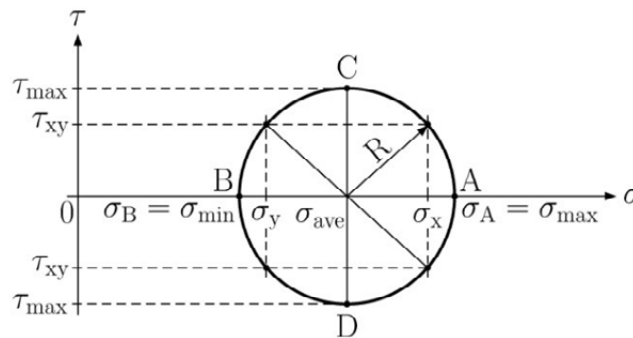


Fig. 4.35

This e-book  
is made with  
**SetaPDF**



PDF components for PHP developers

[www.setasign.com](http://www.setasign.com)

The Mohr circle has four important points denoted by  $B$ ,  $C$ , and  $D$ , see Fig. 4.35. Point  $A$  represents the plane which has the maximum normal stress  $\sigma_{max} = \sigma_A$ ; Point  $B$  represents the plane with minimum normal stress  $\sigma_{min} = \sigma_B$  and points  $C$ ,  $D$  represent the planes with maximum shearing stress  $\tau_{max}$ . Mathematically we have

$$\begin{aligned}\sigma_{max} &= \sigma_A = \sigma_{ave} + R \\ \sigma_{min} &= \sigma_B = \sigma_{ave} - R \\ \tau_{max} &= R\end{aligned}\tag{4.54}$$

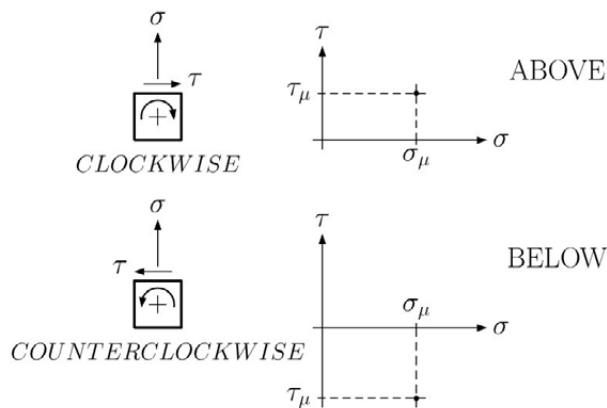


Fig. 4.36

The plane  $A$  contains the normal stress  $\sigma_A$  and zero shearing stress. This plane is known as *the principal plane* and the corresponding normal stress as *the principal stress*. Plane  $B$  is also a principal plane with a principal stress  $\sigma_B$ . Planes  $C$ ,  $D$  are known as *the planes of maximum shearing stresses*. The position of plane  $\mu$  in Mohr's circle depends on the value of the corresponding normal stress  $\sigma$  and the orientation of the shearing stress  $\tau$ . If the shearing stress tends to rotate the element in a *clockwise* manner, the point on Mohr's circle corresponding to that face is located *above* the  $\sigma$  axis. If the shearing stress tends to rotate the element *counterclockwise*, the point on Mohr's circle corresponding to that face is located *below* the  $\sigma$  axis, see Fig. 4.36. In our case (Fig. 3.32) the shearing stress  $\tau_{xy}$  in the plane  $\mu$  tends to rotate the element counterclockwise, so the plane is located below the  $\sigma$  axis, see Fig. 4.37. Pointing out the difference between the unit square and Mohr's circle, the angle  $\theta$  in the unit square is doubled in Mohr's circle. Therefore we have to rotate the plane  $\mu$  by  $2\theta$  in the same direction to get plane  $\eta$ , see Fig. 4.37. The principal planes  $A$ ,  $B$  can be found graphically in the unit square by rotating the plane  $\mu$  about *the principal angle*  $\theta_P$ , see Fig. 4.38. The principal angle can be determined from the condition that there is no shearing stress on the principal plane. Thus we get

$$\tan 2\theta_P = \frac{2\tau_{xy}}{\sigma_x - \sigma_y} \quad \text{or} \quad 2\theta_P = \tan^{-1} \left( \frac{2\tau_{xy}}{\sigma_x - \sigma_y} \right)\tag{4.55}$$

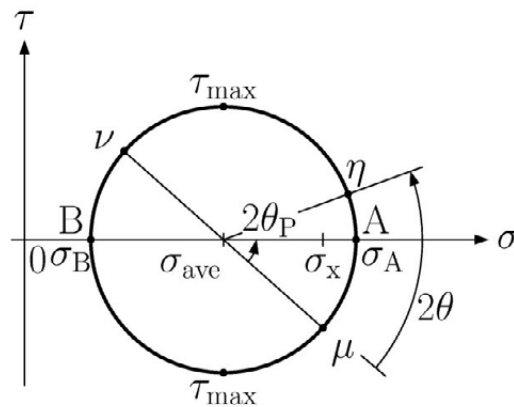


Fig. 4.37

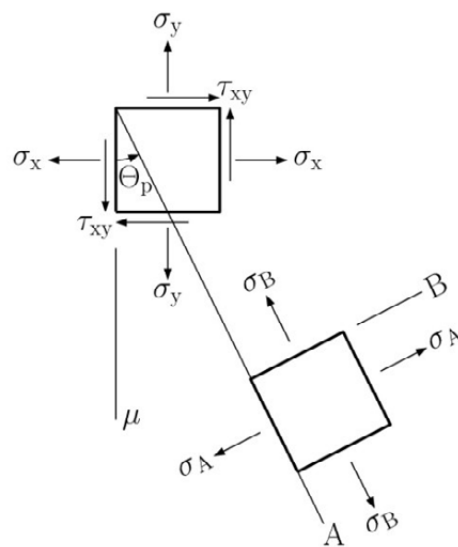


Fig. 4.38

The experimental observations show that the failure of brittle materials depends strongly on the maximum normal stress, i.e. they fail suddenly without any yielding prior. Therefore it is natural that we compare the ultimate normal stress caused by simple uniaxial loading  $\sigma_U$  to the maximum normal stress for a given spatial stress state, i.e. with the maximum principal stress  $\sigma_A$

$$|\sigma_A| \leq \sigma_U \tag{4.56}$$

This equation is known as *Coulomb's criterion* (Ch. Coulomb 1736–1806).

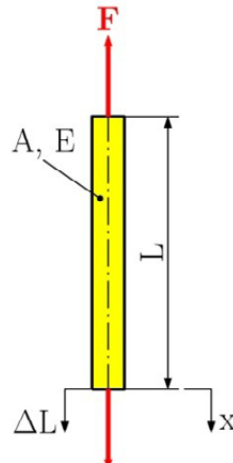


Fig. 4.39

For ductile materials this criterion doesn't apply therefore we must compare other quantities. Usually we compare *the strain energies* which is the energy accumulated in the body during the deformation process with no dissipation (no internal sources of energy). Firstly, we derive the strain energy for a member  $BC$  in tension, see Fig. 4.39. Since there is no dissipation during the deformation process, the strain energy  $U$  is equal to the work done by the external forces  $W$

$$U = W = \int F dx \quad (4.57)$$



Discover the truth at [www.deloitte.ca/careers](http://www.deloitte.ca/careers)

**Deloitte.**

© Deloitte & Touche LLP and affiliated entities.

Dividing equation (4.57) by the volume of the member  $V = AL$  we get *the strain energy density*

$$u = \frac{U}{V} = \int \frac{F}{A} \frac{dx}{L} = \int \sigma_x d\varepsilon_x = \int E \varepsilon_x d\varepsilon_x = E \frac{\varepsilon_x^2}{2} = \frac{\sigma_x \varepsilon_x}{2} = \frac{\sigma_x^2}{2E} \quad (4.58)$$

The total strain energy density for multiaxial loading is equal to the sum of individual strain energy densities for each load. Then we can conclude that

$$u = \frac{\sigma_x \varepsilon_x}{2} + \frac{\sigma_y \varepsilon_y}{2} + \frac{\sigma_z \varepsilon_z}{2} + \frac{\tau_{xy} \gamma_{xy}}{2} + \frac{\tau_{xz} \gamma_{xz}}{2} + \frac{\tau_{yz} \gamma_{yz}}{2} \quad (4.59)$$

For the plane stress state we analogically get

$$u = \frac{\sigma_x \varepsilon_x}{2} + \frac{\sigma_y \varepsilon_y}{2} + \frac{\tau_{xy} \gamma_{xy}}{2} \quad (4.60)$$

Substituting the equations of elasticity (2.10) into equation (4.60) results in

$$u = \frac{1}{E} (\sigma_x^2 + \sigma_y^2 - 2\nu \sigma_x \sigma_y) + \frac{\tau_{xy}^2}{2G} \quad (4.61)$$

and in the terms of the principal stresses we obtain

$$u = \frac{1}{E} (\sigma_A^2 + \sigma_B^2 - 2\nu \sigma_A \sigma_B) \quad (4.62)$$

From the theory of elasticity, the total strain energy density can be decomposed additively in *the volumetric and the distortion parts*. The volumetric part  $u_V$  causes a volumetric change in the body and the distortion part  $u_D$  causes the body's change in shape. Then

$$u = u_V + u_D \quad (4.63)$$

Let us introduce the average value of principal stresses assuming the spatial stress state

$$\bar{\sigma} = \frac{\sigma_A + \sigma_B + \sigma_C}{3}$$

and define that

$$\sigma_A = \bar{\sigma} + \sigma'_A, \quad \sigma_B = \bar{\sigma} + \sigma'_B, \quad \sigma_C = \bar{\sigma} + \sigma'_C \quad (4.64)$$

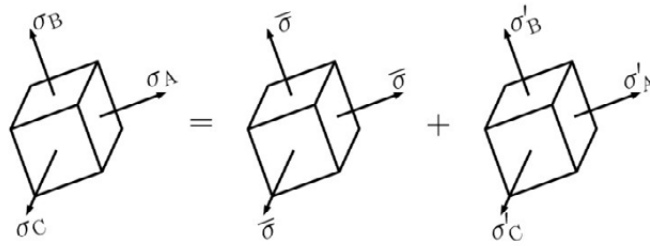


Fig. 4.40

we can then make this decomposition graphically, see Fig. 4.40. From the drawing, it is clear that the stress  $\bar{\sigma}$  causes the volumetric change and the stresses  $\sigma'_A$ ,  $\sigma'_B$ ,  $\sigma'_C$  cause the shape of the body to change. For the plane stress state  $\sigma_C = 0$  and knowing that  $u_D = u - u_V$  we can derive the distortion energy density

$$u_D = \frac{1}{6G} (\sigma_A^2 - \sigma_A \sigma_B + \sigma_B^2) \quad (4.65)$$

Considering the simple tensile test for which  $\sigma_A = \sigma_Y$  and  $\sigma_B = 0$  applies at yield, then the distortion energy  $(u_D)_Y = \sigma_Y^2/6G$ . The maximum distortion energy (Mises criterion), for plane stress, indicates that a given state of stress is safe as long as  $u_D < (u_D)_Y$ . Substituting the strain energy density from equation (4.65) we then get

$$\sigma_A^2 - \sigma_A \sigma_B + \sigma_B^2 < \sigma_Y^2 \quad (4.66)$$

Considering a special case of the plane stress state defined by  $\sigma_x \neq 0, \sigma_y = 0, \tau_{xy} \neq 0$  we can derive the corresponding principal stresses as follows

$$\sigma_A = \frac{\sigma_x}{2} + \sqrt{\left(\frac{\sigma_x}{2}\right)^2 + \tau_{xy}^2} \quad \text{and} \quad \sigma_B = \frac{\sigma_x}{2} - \sqrt{\left(\frac{\sigma_x}{2}\right)^2 + \tau_{xy}^2} \quad (4.67)$$

Then substituting the above equations into equation (4.66), we obtain

$$\sqrt{\sigma_x^2 + 3\tau_{xy}^2} < \sigma_Y \quad (4.68)$$

Now we can apply Mises criterion for checking the connection between the flange and the web, see Fig. 4.29 and assuming a factor of safety  $F.S$  we get the allowable stress for a given material

$$\sigma_{All} = \frac{\sigma_Y}{F.S.} \quad (4.69)$$

and finally we have

$$\sigma_A^2 - \sigma_A \sigma_B + \sigma_B^2 < \sigma_{All}^2 \quad \text{or} \quad \sqrt{\sigma_A^2 - \sigma_A \sigma_B + \sigma_B^2} < \sigma_{All} \quad (4.70)$$

If our design satisfies Mises criterion (4.70) at the flange-web connection, then our design is considered to be safe.

## 4.8 Examples, Solved and Unsolved Problems

### Problem 4.1

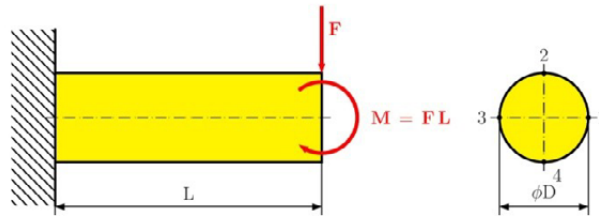


Fig. 4.41

A beam with a circular cross-section acted on by a force  $F$  and bending moment  $M=FL$  seen in the Fig. 4.41. Determine, and draw along its length, the internal moment  $M$  and transversal force  $V$ . Draw the stress distribution over the cross-section at the location of maximum bending moment and determine the von Mises stress at point 1, 2, 3, 4.

### Solution

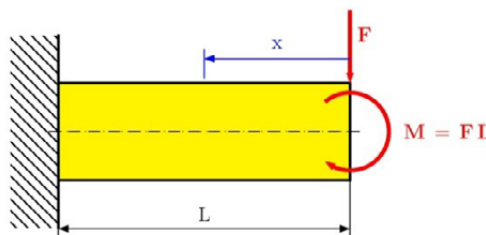


Fig. 4.42

$$x \in \langle 0, L \rangle$$

The shaft consist of one portion (see Fig. 4.42), which has a uniform cross-section area, constant internal bending moment, and constant transversal load. See the free body diagram in Fig. 4.43, from which we find

$$\sum M_{iQ} = 0: M(x) + M + Fx = 0 \Rightarrow M(x) = -M - Fx$$

$$M(x) = -FL - Fx = -F(L + x) \tag{a}$$

$$\sum F_{ix} = 0: N(x) = 0$$

$$\sum F_{iy} = 0: V(x) - F = 0 \Rightarrow V(x) = F \tag{b}$$

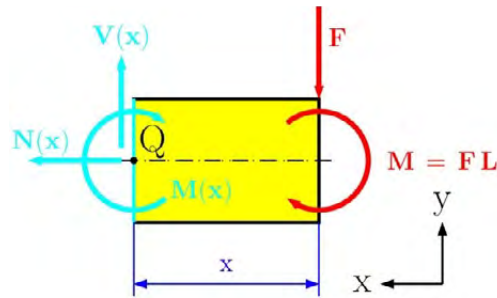


Fig. 3.43

The maximum internal moment in the beam is  $M = 2FL$  at  $x = L$  and the transverse load is constant  $V = F$  along the length of the beam in Fig. 4.44.

Moment of inertia about the neutral axis is

$$I = \frac{\pi D^4}{64}$$

*Maximum bending stress.* The maximum bending stress occurs at the point farthest away from the neutral axis. This is at the top (point 2) and bottom (point 4) of the beam  $c = D/2$ . Thus,

© 2013 Accenture. All rights reserved.

be > your degree

Bring your talent and passion to a global organization at the forefront of business, technology and innovation. Discover how great you can be.

Visit [accenture.com/bookboon](http://accenture.com/bookboon)

Be greater than.  
consulting | technology | outsourcing

accenture  
High performance. Delivered.



$$\sigma_{\max} = \frac{M}{I} c = \frac{M D}{I 2}$$

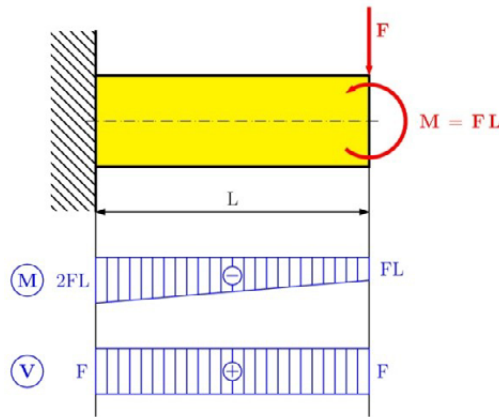


Fig. 4.44

$s_{\max}$  is the maximum absolute value from Eq. (a), which is located at  $x = L$  and we get

$$\sigma_{\max} = \frac{2FL D}{\pi D^4 \frac{2}{64}} = \frac{64 FL}{\pi D^3} = 20.37 \frac{FL}{D^3}$$

The maximum shear stress occurs at the neutral axis for a circular cross-section which is

$$\tau_{\max} = \frac{V Q}{I t} = \frac{4 Q}{3 A} = \frac{4 Q}{3 \pi D^2} = \frac{16 Q}{3 \pi D^2}$$

Graphically, the bending stress and shearing stress are shown in Fig. 4.45. Von Mises criterion says

$$\sigma_{\text{Mises}} = \sqrt{\sigma^2 + 3\tau^2} \leq \sigma_{\text{all}} \tag{c}$$

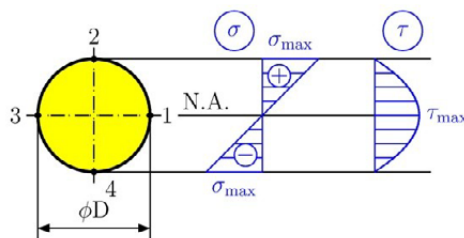


Fig. 4.45

The Mises stress at point 1 and 3 in Fig. 4.45 is the same, because from the diagram in the Fig. the bending stress is  $s = 0$  and the shearing stress is at its maximum  $\tau = \tau_{\max}$ , which is

$$\sigma_{\text{Mises}} = \sqrt{(0)^2 + 3\left(\frac{16}{3\pi} \frac{Q}{D^2}\right)^2} = \sqrt{3} \frac{16}{3\pi} \frac{Q}{D^2}$$

The Mises stress at point 2 and 4 in Fig. 4.45 is the same because, from the diagram in the figure, the bending moment is at its maximum  $\sigma = \sigma_{\text{max}}$  and the shearing stress is

$\tau = 0$ , which is

$$\sigma_{\text{Mises}} = \sqrt{\left(\frac{64}{\pi} \frac{FL}{D^3}\right)^2 + 3(0)^2} = \frac{64}{\pi} \frac{FL}{D^3}$$

### Problem 4.2

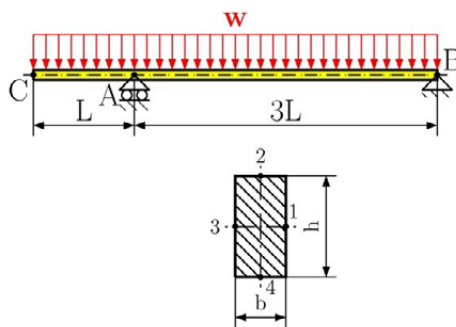


Fig. 4.46

For the beam with a load shown in Fig. 4.46, determine (a) the equation defining the transversal load and bending moment at any point (b) draw the shear and bending moment diagram (c) locate the maximum bending moment and maximum transversal load (d) determine the von Mises stress at point 1, 2, 3, 4 for a rectangular cross-section area

### Solution

The shaft consists of two portions, AB and AC (see Fig. 4.47), and each portion has uniform cross-section and constant external forces.

#### Reactions

Considering the free body diagram of the entire beam (Fig. 4.47), we write

$$\sum F_{ix} = 0: -R_{Bx} = 0 \quad \Rightarrow \quad R_{Bx} = 0$$

$$\sum M_{iA} = 0: R_B 3L - w 3L \frac{3L}{2} + wL \frac{L}{2} = 0 \quad \Rightarrow \quad R_{Bx} = \frac{4}{3} wL$$

$$\sum F_{iy} = 0: R_A + R_B - 4wL = 0 \quad \Rightarrow \quad R_A = 4wL - R_B = \frac{8}{3} wL$$

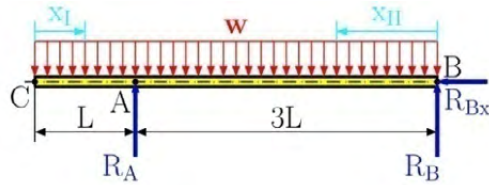


Fig. 4.47

*Solution of portion AC*

Passing a section through the beam between A and C and using the free body diagram shown in Fig. 4.48, we find

$$\sum M_{iQ} = 0: M_1(x_1) + w x_1 \frac{x_1}{2} = 0$$

$$M_1(x_1) = -\frac{w x_1^2}{2}$$

$$\sum F_{iy} = 0: -V_1(x_1) - w x_1 = 0$$

$$V_1(x_1) = -w x_1$$

# The Wake

the only emission we want to leave behind

Low-speed Engines Medium-speed Engines Turbochargers Propellers Propulsion Packages PrimeServ

The design of eco-friendly marine power and propulsion solutions is crucial for MAN Diesel & Turbo. Power competencies are offered with the world's largest engine programme – having outputs spanning from 450 to 87,220 kW per engine. Get up front! Find out more at [www.mandieselturbo.com](http://www.mandieselturbo.com)

Engineering the Future – since 1758.

## MAN Diesel & Turbo

The diagram of transversal load and bending moment is shown in Fig. 4.50.

$$x_I \in \langle 0, L \rangle$$

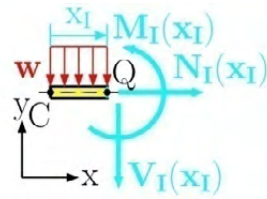


Fig. 4.48

$$x_{II} \in \langle 0, 3L \rangle$$

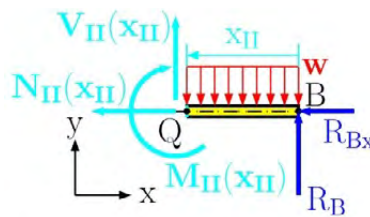


Fig. 4.49

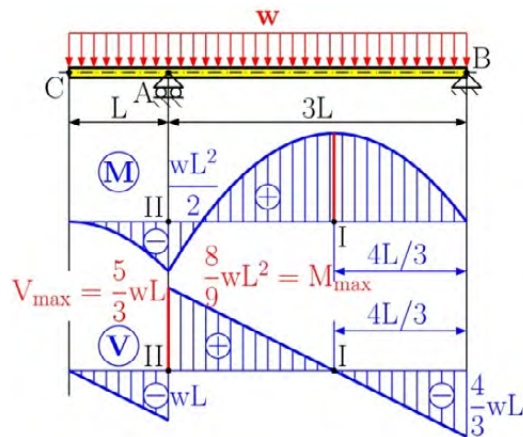


Fig. 4.50

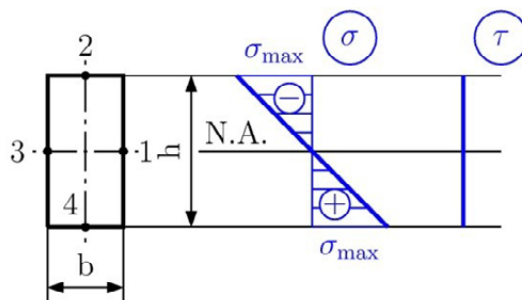


Fig. 4.51

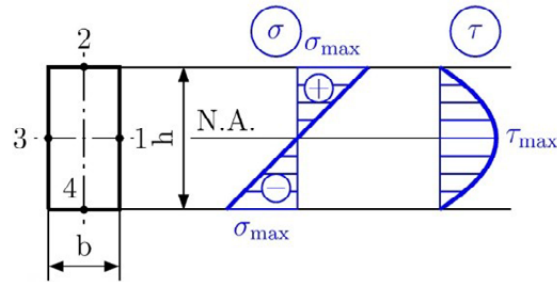


Fig. 4.52

### Solution of portion AB

Now passing a section between A and B, we have (see Fig. 4.49)

$$\sum M_{iQ} = 0: -M_{II}(x_{II}) + R_B - \frac{w x_{II}^2}{2} = 0$$

$$M_{II}(x_{II}) = R_B - \frac{w x_{II}^2}{2} = \frac{4}{3} w L x_{II} - \frac{w x_{II}^2}{2}$$

$$\sum F_{iy} = 0: V_{II}(x_{II}) - w x_{II} + R_B = 0$$

$$V_{II}(x_{II}) = w x_{II} - R_B = w x_{II} - \frac{4}{3} w L$$

Graphically the transversal load and bending moment is shown in Fig. 4.50. We have two points with the local maximum values. At point I we have the maximum bending moment while the transversal load is zero. At point II we have a nonzero bending moment and the maximum transversal load. We will control the rectangular cross-section area at both points.

### Von Mises stress at point I in Fig. 4.50.

At this location we only have a nonzero maximum value of the bending moment. At this point we have pure bending. The maximum value of stress is at points 2 and 4 (see Fig. 4.51), which are

$$\sigma_{\max} = \frac{|M_{\max}|}{S} = \frac{|M_{\max}|}{I_z} y_{\max} = \frac{|M_{\max}|}{\frac{1}{12} b h^3} \frac{h}{2} = \frac{6 |M_{\max}|}{b h^2}$$

$$\sigma_{\max} = \frac{6 |M_{\max}|}{b h^2} = \frac{6 \left| \frac{8}{9} w L^2 \right|}{b h^2} = \frac{16}{3} \frac{w L^2}{b h^2} \leq \sigma_{\text{all}}$$

Von Mises stress at point II in Fig. 4.50.

At this location, we have a nonzero value of the bending moment and the maximum transversal load. The maximum bending stress is at points 2 and 4 (see Fig. 4.52) , which are

$$\sigma_{\max} = \frac{|M|}{S} = \frac{|M|}{I_z} y_{\max} = \frac{|M|}{\frac{1}{12}bh^3} \frac{h}{2} = \frac{6|M|}{bh^2}$$

$$\sigma_{\max} = \frac{6|M|}{bh^2} = \frac{6wL}{bh^2},$$

Where the shearing stress is zero. The Von Mises stress at points 2 and 4 are

$$\sigma_{\text{Mises}} = \sqrt{\sigma^2 + 3\tau^2} = \sqrt{\left(\frac{6wL}{bh^2}\right)^2 + 3 \times 0^2}$$

$$\sigma_{\text{Mises}} = \frac{6wL}{bh^2} \leq \sigma_{\text{all}}.$$

FREE  
30 days trial!

## SMS from your computer

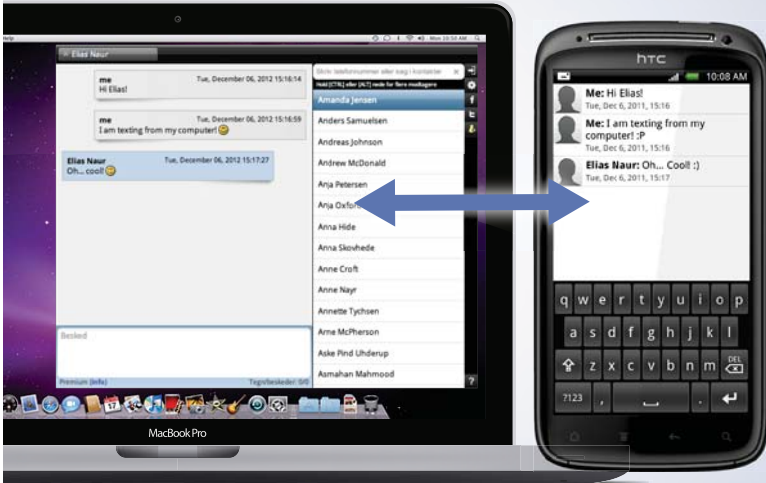
...Sync'd with your Android phone & number

Go to

[BrowserTexting.com](http://BrowserTexting.com)

and start texting from your computer!

BrowserTexting



At points 1 and 3, the bending stress is zero and we only have the maximum shearing stress, which is

$$Q = A\bar{y} = \left(b \times \frac{h}{2}\right) \times \frac{h}{4} = \frac{bh^2}{8}$$

$$\tau_{\max} = \frac{|V|Q}{t I_z} = \frac{V \times \frac{bh^2}{8}}{b \times \frac{1}{12}bh^3} = \frac{3V}{2bh} = \frac{3}{2} \frac{\frac{5}{3}wL}{bh} = \frac{5wL}{2bh}$$

The Von Mises stress at points 1 and 3 are

$$\sigma_{\text{Mises}} = \sqrt{\sigma^2 + 3\tau^2} = \sqrt{(0)^2 + 3 \times \left(\frac{5wL}{2bh}\right)^2}$$

$$\sigma_{\text{Mises}} = \sqrt{3}\tau = \sqrt{3} \left(\frac{5wL}{2bh}\right) \leq \sigma_{\text{all}}$$

### Problem 4.3

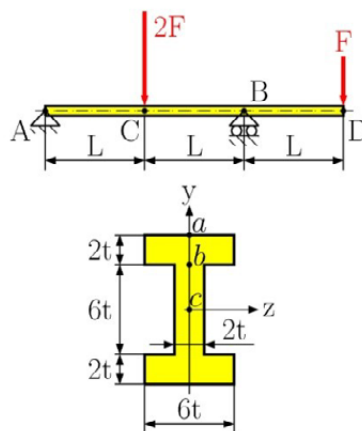


Fig. 4.53

For the beam with a load shown in Fig. 4.53, determine (a) the equation defining the transverse load and bending moment at any point (b) draw the shear and bending moment diagram (c) locate the maximum bending moment and maximum transverse load. (d) design the cross-section area at point *a*, *b* and *c*.

### Solution

The shaft consists of three portions AC, CB, and BD (see Fig. 4.53), each with a uniform cross-section and constant external forces.

*Reactions*

Considering the free body diagram of the entire beam (Fig. 4.54), we write

$$\sum F_{ix} = 0: R_{Ax} = 0$$

$$\sum M_{iA} = 0: 2FL - R_B 2L + F3L = 0 \quad \Rightarrow \quad R_B = \frac{5}{2}F$$

$$\sum F_{iy} = 0: R_A + R_B - 2F - F = 0 \quad \Rightarrow \quad R_A = 3F - R_B = 3F - \frac{5}{2}F = \frac{F}{2}$$

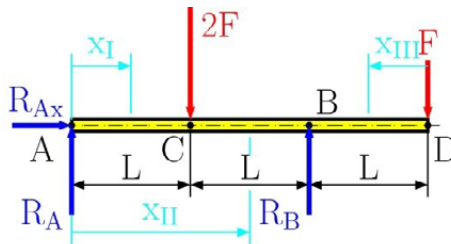


Fig. 4.54

$$x_I \in \langle 0, L \rangle$$

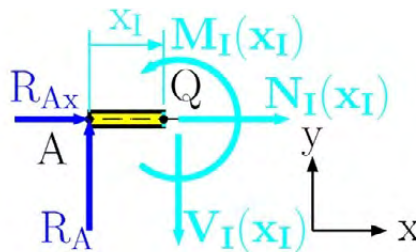


Fig. 4.55

*Solution of part AC.*

At position  $x_I$  we assign the internal forces and moment to be positive as shown in Fig. 4.55. We find the internal forces and bending moment from the following equilibrium equations:

$$\sum M_{iQ} = 0: M_I(x_I) - R_A x_I = 0$$

$$M_I(x_I) = R_A x_I = \frac{F}{2} x_I$$

$$\sum F_{iy} = 0: -V_I(x_I) + R_A = 0$$

$$V_I(x_I) = R_A = \frac{F}{2}$$

$$\sum F_{ix} = 0: N_I(x_I) + R_{Ax} = 0 \quad N_I(x_I) = 0$$

*Solution of part CB.*

In the same way as the solution of part AC, we write the equilibrium equations for part CB (Fig. 4.56), which are

$$\sum M_{iQ} = 0: M_{II}(x_{II}) - R_A x_{II} + 2F(x_{II} - L) = 0$$

$$M_{II}(x_{II}) = R_A x_{II} - 2F(x_{II} - L) = -\frac{3}{2}Fx_{II} + 2FL$$

$$\sum F_{iy} = 0: -V_{II}(x_{II}) + R_A - 2F = 0$$

$$V_{II}(x_{II}) = R_A - 2F = \frac{F}{2} - 2F = -\frac{3}{2}F$$

$$\sum F_{ix} = 0: N_{II}(x_{II}) + R_{Ax} = 0 \quad N_{II}(x_{II}) = 0$$

*Solution of part BD.*

$$x_{II} \in \langle L, 2L \rangle$$

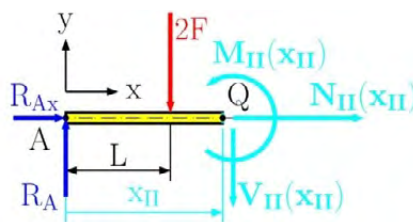


Fig. 4.56

$$x_{III} \in \langle 0, L \rangle$$

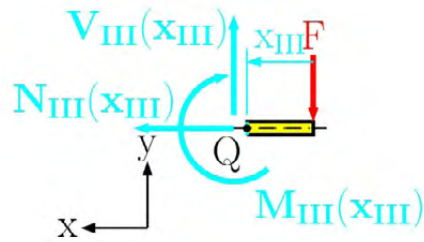


Fig. 4.57

Part BD is shown in Fig. 4.57 with the internal forces (transversal  $V$  and normal  $N$  force) and internal bending moment located at point  $Q$ . We solve these internal forces and moment from the following equation

$$\sum M_{iQ} = 0: M_{III}(x_{III}) + F x_{III} = 0$$

$$M_{III}(x_{III}) = -F x_{III}$$

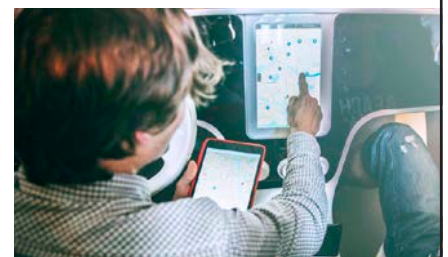
$$\sum F_{iy} = 0: V_{III}(x_{III}) - F = 0$$

$$V_{III}(x_{III}) = F$$

**YOUR WORK AT TOMTOM WILL  
BE TOUCHED BY MILLIONS.  
AROUND THE WORLD. EVERYDAY.**

Join us now on [www.TomTom.jobs](http://www.TomTom.jobs)

follow us on **LinkedIn**



**#ACHIEVEMORE**

**TOMTOM** 

$$\sum F_{ix} = 0: -N_{III}(x_{III}) = 0 \quad N_{III}(x_{III}) = 0$$

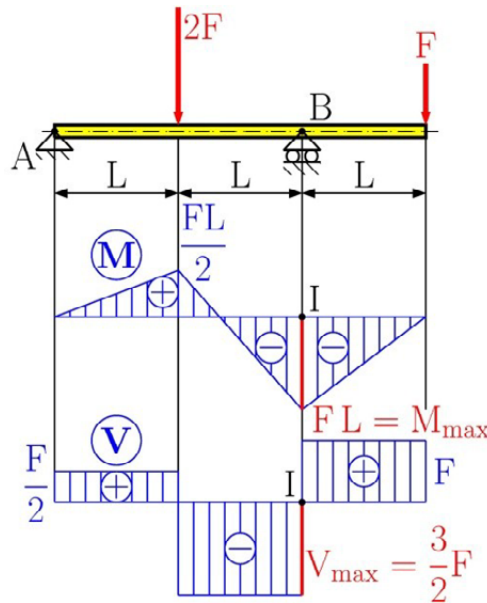


Fig. 4.58

Graphically the transversal load and bending moment for all parts can be seen in Fig. 4.58. From this Fig. 4.58, the maximum transversal load and bending moment can be found at  $x_{II} = 2L$ . Maximum values at this location (point I) are

$$M_{\max} = M_{II}(x_{II}=2L) = -F L$$

$$V_{\max} = V_{II}(x_{II}=2L) = -\frac{3}{2} F$$

Normal Stress on the Transverse Plane. (see Fig. 4.59)

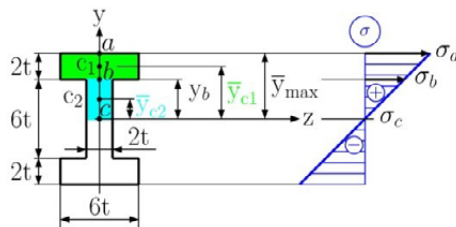


Fig. 4.59

For the cross-sectional area in Fig. 4.59 we have  $I_z = 428 t^4$  from Appendix – Example A.06. We determine the stresses  $\sigma_a$ ,  $\sigma_b$  and  $\sigma_c$ .

at point  $a$ :

$$\sigma_a = \frac{|M_{\max}|}{S} = \frac{|M_{\max}|}{I_z} y_{\max} = \frac{FL}{428 t^4} 5t = \frac{5}{428} \frac{FL}{t^3}$$

and at point  $b$ :

$$\sigma_b = \sigma_a \frac{y_b}{y_{\max}} = \frac{5}{428} \frac{FL}{t^3} \frac{3t}{5t} = \frac{3}{428} \frac{FL}{t^3}$$

and at point  $c$ :

$$\sigma_c = \sigma_a \frac{y_c}{y_{\max}} = \frac{5}{428} \frac{FL}{t^3} \frac{0}{5t} = 0$$

*Shearing Stress on the Transverse Plane.*

At point  $a$ :  $Q = 0$   $\tau_a = 0$

At point  $b$ :  $Q = A\bar{y}_{c1} = (6t \times 2t) \times 4t = 48t^3$

$$\tau_b = \frac{|V|Q}{t I_z} = \frac{\frac{3}{2}F \times 48t^3}{2t \times 428t^4} = \frac{9}{107} \frac{F}{t^2}$$

At point  $c$ :

$$Q = A_1\bar{y}_{c1} + A_2\bar{y}_{c2} = (6t \times 2t) \times 4t + (2t \times 3t) \times \frac{3}{2}t = 57t^3$$

$$\tau_c = \frac{|V|Q}{t I_z} = \frac{\frac{3}{2}F \times 57t^3}{2t \times 428t^4} = \frac{171}{1712} \frac{F}{t^2}$$

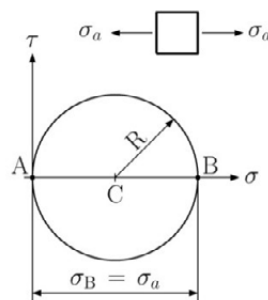


Fig. 4.60

*Principal stress at Point a.* The stress state at point  $a$  consists of the normal stress  $\sigma_a$  and the shearing stress  $\tau_a = 0$ . Drawing Mohr's circle (Fig. 4.60) we find

$$\sigma_{\max} = \sigma_a = \frac{5}{428} \frac{FL}{t^3} \leq \sigma_{\text{all}}$$

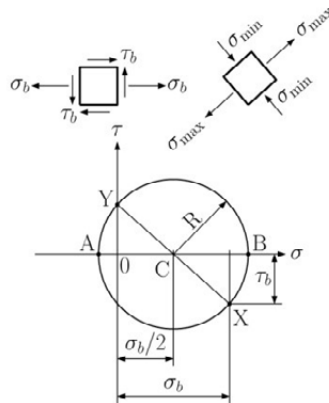


Fig. 4.61

*Principal stress at Point b.* The stress state at point *b* consists of the normal stress  $s_b$  and the shearing stress  $t_b$ . We draw Mohr's circle (Fig. 4.61) and find

$$\sigma_{\max} = \frac{\sigma_b}{2} + R = \frac{\sigma_b}{2} + \sqrt{\left(\frac{\sigma_b}{2}\right)^2 + \tau_b^2}$$

# Brain power



Plug into The Power of Knowledge Engineering.  
Visit us at [www.skf.com/knowledge](http://www.skf.com/knowledge)

By 2020, wind could provide one-tenth of our planet's electricity needs. Already today, SKF's innovative know-how is crucial to running a large proportion of the world's wind turbines.

Up to 25 % of the generating costs relate to maintenance. These can be reduced dramatically thanks to our systems for on-line condition monitoring and automatic lubrication. We help make it more economical to create cleaner, cheaper energy out of thin air.

By sharing our experience, expertise, and creativity, industries can boost performance beyond expectations. Therefore we need the best employees who can meet this challenge!

The Power of Knowledge Engineering



$$\sigma_{\max} = \frac{1}{2} \frac{3}{428} \frac{FL}{t^3} + \sqrt{\left(\frac{1}{2} \frac{3}{428} \frac{FL}{t^3}\right)^2 + \left(\frac{9}{107} \frac{F}{t^2}\right)^2} \leq \sigma_{\text{all}}$$

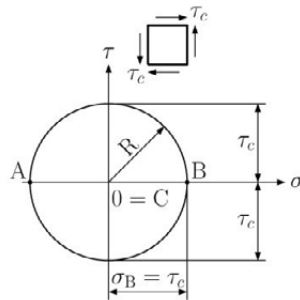


Fig. 4.62

Principal stress at Point *c*. The stress state at point *c* consists of the normal stress  $\sigma_c = 0$  and shearing stress  $\tau_c$ . Drawing Mohr's circle (Fig. 4.62) we find

$$\sigma_{\max} = R = \tau_c = \frac{171}{1712} \frac{F}{t^2} \leq \sigma_{\text{all}}$$

**Problem 4.4**

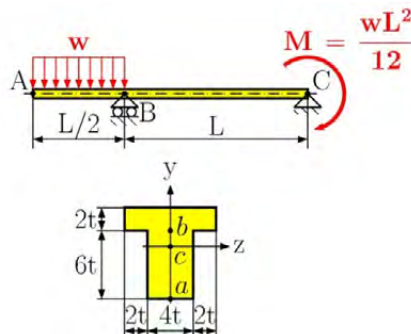


Fig. 4.63

For the loaded beam in Fig. 4.63, determine (a) the equation defining the transversal load and bending moment at any point, (b) the location of the maximum bending moment and maximum transversal load (c) draw the shear and bending moment diagram and design, for the given cross-section area, using von Mises criterion. (d) calculate the principal stresses at point *a*, *b* and *c*.

**Solution**

*Reactions*

Considering the free body diagram (Fig. 4.64), we write

$$\sum F_{ix} = 0: R_{Bx} = 0$$

$$\sum M_{iB} = 0: w \frac{L}{2} \left( L + \frac{L}{4} \right) - R_A L - M = 0 \quad \Rightarrow \quad R_B = 0.542wL$$

$$\sum F_{iy} = 0: -\frac{wL}{2} + R_A + R_B = 0 \quad \Rightarrow \quad R_A = \frac{wL}{2} - R_B = -0.042wL$$

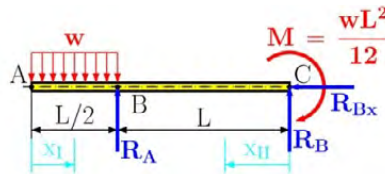


Fig. 4.64

$$x_I \in \langle 0, L/2 \rangle$$

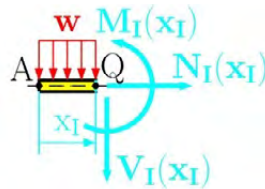


Fig. 4.65

(a) the equation defining the transversal load and bending moment at any point

We must consider the solution of two parts (part AB and BC). For both parts we find the bending moment and transversal load. The normal load is equal to zero for all parts because we don't have an axial load.

*Solution of part AB in the Fig. 4.65.*

$$\sum M_{iQ} = 0: M_I(x_I) + w x_I \frac{x_I}{2} = 0$$

$$M_I(x_I) = -\frac{w x_I^2}{2}$$

$$\sum F_{iy} = 0: -V_I(x_I) - w x_I = 0$$

$$V_I(x_I) = -w x_I$$

$$\sum F_{ix} = 0: N_I(x_I) = 0$$

$$x_{II} \in \langle 0, L \rangle$$

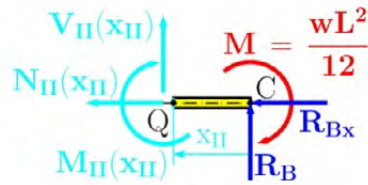


Fig. 4.66

*Solution of part BC in the Fig. 4.66.*

$$\sum M_{iQ} = 0: -M_{II}(x_{II}) - M + R_B x_{II} = 0$$

$$M_{II}(x_{II}) = -M + R_B x_{II} = -\frac{wL^2}{12} - 0.042wLx_{II}$$

$$\sum F_{iy} = 0: V_{II}(x_{II}) + R_B = 0$$

$$V_{II}(x_{II}) = -R_B = 0.042wL$$

$$\sum F_{ix} = 0: N_{II}(x_{II}) = 0$$

**> Apply now**

REDEFINE YOUR FUTURE  
**AXA GLOBAL GRADUATE  
 PROGRAM 2015**

redefining / standards 

agence.cdg. © Photonistop

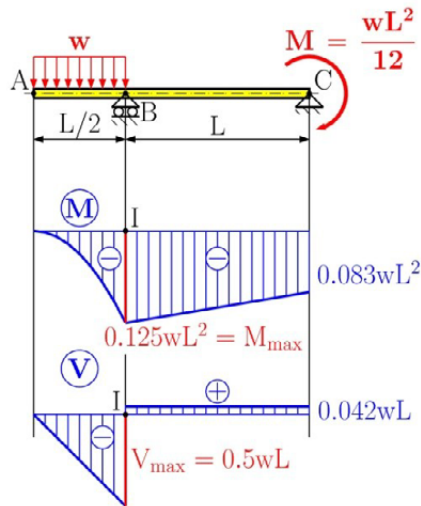


Fig. 4.67

(b) location of maximum bending moment and maximum transversal load

Graphically, the transversal load and bending moment can be seen in Fig. 4.67. From the graphical solution, the position of maximum bending moment and transversal load is at the same point, point I (or point B) at

$$x_I = \frac{L}{2}$$

where the maximum value of bending moment and transversal load is

$$M_{\max} = M_I(x_I=L/2) = -0.125wL^2$$

$$V_{\max} = V_I(x_I=L/2) = -0.5wL$$

(d) Design the cross-section area at point *a*, *b* and *c*.

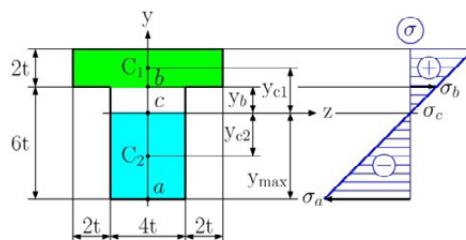


Fig. 4.68

*Normal stress on Transverse Plane.* (see Fig. 4.68)

For cross-section area in the Fig. 4.68 we have  $I_z = 230.9t^4$  and  $y_c = 4.6t$  from the Appendix – Example A.05. Determining the stresses  $\sigma_a$ ,  $\sigma_b$  and  $\sigma_c$ , we write for point  $a$ :

$$\sigma_a = \frac{|M_{\max}|}{S} = \frac{|M_{\max}|}{I_z} y_{\max} = \frac{0.125 wL^2}{230.9 t^4} 4.6t = 2.5 \times 10^{-3} \frac{wL^2}{t^3}$$

point  $b$ :

$$\sigma_b = \sigma_a \frac{y_b}{y_{\max}} = 2.5 \times 10^{-3} \frac{wL^2}{t^3} \frac{1.4t}{4.6t} = 7.61 \times 10^{-4} \frac{wL^2}{t^3}$$

point  $c$ :

$$\sigma_c = \sigma_a \frac{y_c}{y_{\max}} = 2.5 \times 10^{-3} \frac{wL^2}{t^3} \frac{0}{4.6t} = 0$$

*Shearing stress on the Transverse Plane.*

At point  $a$ :  $Q = 0$   $\tau_a = 0$

At point  $b$ :

$$Q = A \bar{y}_{c1} = (8t \times 2t) \times 2.4t = 38.4t^3$$

$$\tau_b = \frac{|V|Q}{t I_z} = \frac{0.5wL \times 38.4t^3}{4t \times 230.9t^4} = 0.021 \frac{wL}{t^2}$$

At point  $c$ :

$$Q = A_2 \bar{y}_{c2} = (4.6t \times 4t) \times 2.3t = 42.32t^3$$

$$\tau_c = \frac{|V|Q}{t I_z} = \frac{0.5wL \times 42.32t^3}{4t \times 230.9t^4} = 0.023 \frac{wL}{t^2}$$

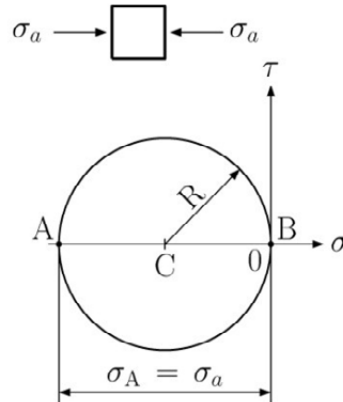


Fig. 4.69

*Principal stress at Point a.* The stress state at point  $a$  consists of the normal stress  $\sigma_a$  and the shearing stress  $\sigma_a = 0$ . drawing Mohr's circle (Fig. 4.69) we find

$$\sigma_{\max} = \sigma_a = 2.5 \times 10^{-3} \frac{wL^2}{t^3} \leq \sigma_{\text{all}}$$

## LIGS University

based in Hawaii, USA

is currently enrolling in the  
Interactive Online **BBA, MBA, MSc,**  
**DBA and PhD** programs:

- ▶ enroll **by October 31st, 2014** and
- ▶ **save up to 11%** on the tuition!
- ▶ pay in 10 installments / 2 years
- ▶ Interactive **Online** education
- ▶ visit [www.ligsuniversity.com](http://www.ligsuniversity.com) to find out more!

Note: LIGS University is not accredited by any nationally recognized accrediting agency listed by the US Secretary of Education. More info [here](#).



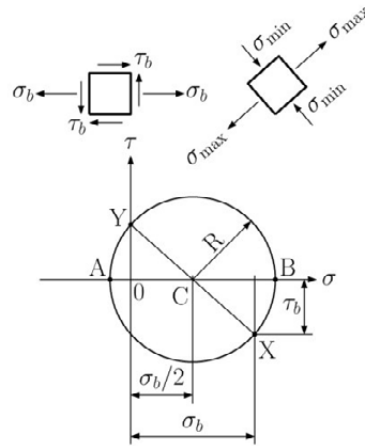


Fig. 4.70

*Principal stress at Point b.* The stress state of point  $b$  consists of the normal stress  $\sigma_b$  and shearing stress  $\tau_b$ . Drawing Mohr's circle (Fig. 4.70) we find

$$\sigma_{\max} = \frac{\sigma_b}{2} + R = \frac{\sigma_b}{2} + \sqrt{\left(\frac{\sigma_b}{2}\right)^2 + \tau_b^2}$$

$$\sigma_{\max} = \frac{2.5 \times 10^{-3} wL^2}{2 t^3} + \sqrt{\left(\frac{2.5 \times 10^{-3} wL^2}{2 t^3}\right)^2 + \left(0.021 \frac{wL}{t^2}\right)^2}$$

$$\sigma_{\max} \leq \sigma_{\text{all}}$$

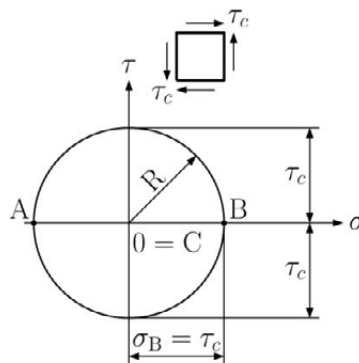


Fig. 4.71

*Principal stress at Point c.* The stress state at point  $c$  consists of the normal stress  $\sigma_c = 0$  and shearing stress  $\tau_c$ . Drawing Mohr's circle (Fig. 4.71) we find

$$\sigma_{\max} = R = \tau_c = 0.023 \frac{wL}{t^2} \leq \sigma_{\text{all}}$$

## Problem 4.5

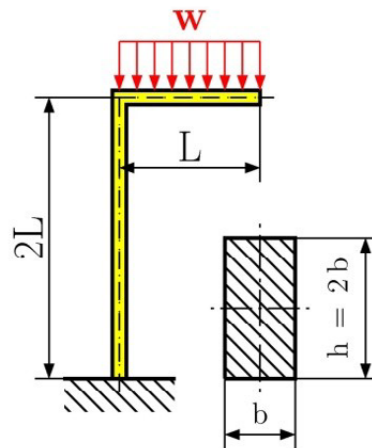


Fig. 4.72

For the loaded beam in Fig. 4.72 determine (a) the equation defining the transversal, normal (axial) load, and bending moment at any point, (b) location of maximum bending moment, maximum transversal load, and maximum normal load (c) draw the normal and transversal load and bending moment diagram and design for the given cross-section area in the critical location using von Mises criterion.

## Solution

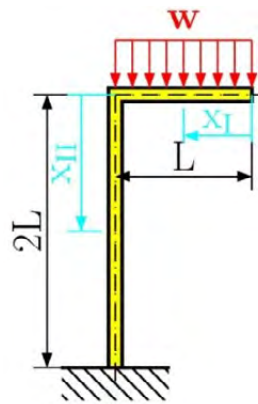


Fig. 4.73

$$x_1 \in \langle 0, L \rangle$$

(a) the equation defining the transversal and normal (axial) load and bending moment at any point

We have a beam with a free end. From the free end, we have constant cross-section area, constant bending moment, transversal load, and normal load. Thus we do not need to find the reactions at the support. The division into the parts is shown in the Fig. 4.73.

Solution of the first part in Fig. 4.74.

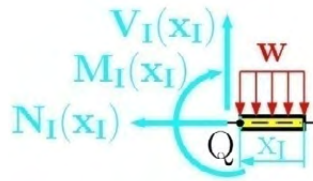


Fig. 4.74

$$x_{II} \in \langle 0, 2L \rangle$$

At location  $x_I$  we assign the positive orientation of the normal force  $N_I$ , transversal force  $V_I$  and bending moment  $M_I$ . We find these forces and moments from the following equilibrium equations:

$$\sum M_{iQ} = 0: -M_I(x_I) - w x_I \frac{x_I}{2} = 0$$

$$M_I(x_I) = -\frac{w x_I^2}{2}$$

$$\sum F_{iy} = 0: V_I(x_I) - w x_I = 0$$

$$V_I(x_I) = w x_I$$

$$\sum F_{ix} = 0: N_I(x_I) = 0$$

## TURN TO THE EXPERTS FOR SUBSCRIPTION CONSULTANCY

Subscribe is one of the leading companies in Europe when it comes to innovation and business development within subscription businesses.

We innovate new subscription business models or improve existing ones. We do business reviews of existing subscription businesses and we develop acquisition and retention strategies.

Learn more at [linkedin.com/company/subscribe](https://www.linkedin.com/company/subscribe) or contact Managing Director Morten Suhr Hansen at [mha@subscribe.dk](mailto:mha@subscribe.dk)

**SUBSCR**✓**BE** - to the future

Solution of the second part in Fig. 4.75.

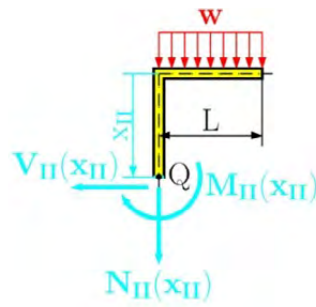


Fig. 4.75

The second part starts from the 90° bend in the beam see Fig. 4.73. For solution we use the positive normal force  $N_{II}$ , transversal force  $V_{II}$  and bending moment  $M_{II}$ , see Fig. 4.75. Equilibrium equations at point Q are

$$\sum M_{iQ} = 0: -M_{II}(x_{II}) - wL \frac{L}{2} = 0$$

$$M_{II}(x_{II}) = -\frac{wL^2}{2}$$

$$\sum F_{iy} = 0: -V_{II}(x_{II}) = 0$$

$$V_{II}(x_{II}) = 0$$

$$\sum F_{ix} = 0: -N_{II}(x_{II}) - wL = 0$$

$$N_{II}(x_{II}) = -wL$$

(b) location of maximum bending moment, maximum transversal load and maximum normal load

The graphical diagram of the normal load, transversal load, and bending moment for both parts can be seen in Fig. 4.76. the design has its maximum values in point I at location

$$x_I = L$$

with values

$$M_{\max} = M_I(x_I=L) = -\frac{wL^2}{2}$$

$$V_{\max} = V_I(x_I=L) = wL$$

$$N_I(x_I=L) = 0$$

and second position (because here the maximum normal load occurs) is in the same point I at location

$$x_{II} = 0$$

with values

$$M_{\max} = M_{II}(x_{II}=0) = -\frac{wL^2}{2}$$

$$V_{II}(x_{II}=0) = 0$$

$$N_{\max} = N_{II}(x_{II}=0) = -wL$$

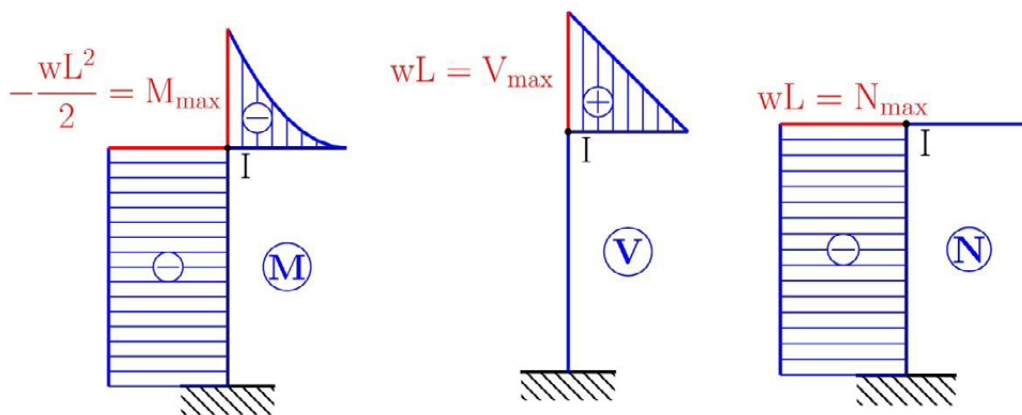


Fig. 4.76

For the given cross-section area we design for both positions.

*Design of rectangular cross-section at point I, when  $x_I = L$ .*

The maximum bending stress is

$$\sigma_{\max} = \frac{|M_{\max}|}{S} = \frac{|M_{\max}|}{I_z} y_{\max} = \frac{|M_{\max}|}{\frac{1}{12}bh^3} \frac{h}{2} = \frac{6|M_{\max}|}{bh^2}$$

$$\sigma_{\max} = \frac{3 \left| -\frac{wL^2}{2} \right|}{2b^3} = \frac{3wL^2}{4b^3}$$

The shearing stress is (from Problem 4.2)

$$\tau_{\max} = \frac{|V|Q}{t I_z} = \frac{3}{2} \frac{V}{bh} = \frac{3}{2} \frac{wL}{bh} = \frac{3}{4} \frac{wL}{b^2},$$

and the normal stress is

$$\sigma_N = \frac{|N|}{A} = \frac{|N|}{bh} = 0.$$

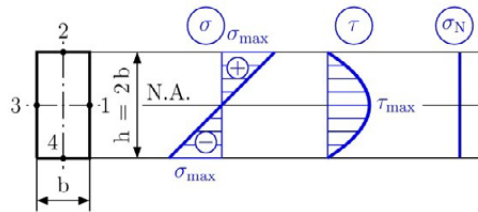


Fig. 4.77

The bending, normal and shearing stress diagram is shown in Fig. 4.77. Von Mises stress at point 2 and 4, when the bending stress is nonzero, is

$$\sigma_{\text{Mises}} = \sqrt{\sigma^2 + 3 \times 0^2} = \sigma = \frac{3wL^2}{4b^3} \leq \sigma_{\text{all}},$$

and at point 1 and 3, when the shearing stress is nonzero, we get

$$\sigma_{\text{Mises}} = \sqrt{0^2 + 3\tau^2} = \sqrt{3} \times \tau = \sqrt{3} \frac{3}{4} \frac{wL}{b^2} \leq \sigma_{\text{all}}.$$

*Design of rectangular cross-section at point I, when  $x_{II} = 0$ .*

The maximum bending stress is

$$\sigma_{\text{max}} = \frac{|M_{\text{max}}|}{S} = \frac{|M_{\text{max}}|}{I_z} y_{\text{max}} = \frac{|M_{\text{max}}|}{\frac{1}{12}bh^3} \frac{h}{2} = \frac{6|M_{\text{max}}|}{bh^2}$$

$$\sigma_{\text{max}} = \frac{3 \left| \frac{wL^2}{2} \right|}{2b^3} = \frac{3wL^2}{4b^3}$$

The shearing stress is (from Problem 4.2)

$$\tau_{\text{max}} = \frac{|V|Q}{t I_z} = \frac{3}{2} \frac{V}{bh} = \frac{3}{2} \frac{0}{bh} = 0,$$

and the normal stress is

$$\sigma_N = \frac{|N|}{A} = \frac{|N|}{bh} = \frac{wL}{bh}.$$

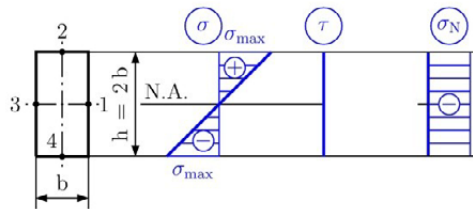


Fig. 4.78

The bending, normal and shearing stress diagram is in Fig. 4.78. The Von Mises stress at point 2 is

$$\sigma_{\text{Mises}} = \sqrt{(\sigma_{\text{max}} - \sigma_N)^2 + 3 \times 0^2} = |\sigma_{\text{max}} - \sigma_N|$$

$$\sigma_{\text{Mises}} = \left| \frac{3wL^2}{4b^3} - \frac{wL}{bh} \right| \leq \sigma_{\text{all}}$$

Note that in this point we have a different sign for the bending and normal stress.

The Von Mises stress at point 4 is

$$\sigma_{\text{Mises}} = \sqrt{(\sigma_{\text{max}} + \sigma_N)^2 + 3 \times 0^2} = |\sigma_{\text{max}} + \sigma_N|$$

$$\sigma_{\text{Mises}} = \left| \frac{3wL^2}{4b^3} + \frac{wL}{bh} \right| \leq \sigma_{\text{all}}$$

Note that, in this point we have the same sign as the bending and normal stress.

At point 1 and 3, all stresses are zero and we get

$$\sigma_{\text{Mises}} = \sqrt{0^2 + 3 \times 0^2} = 0.$$

**Problem 4.6**

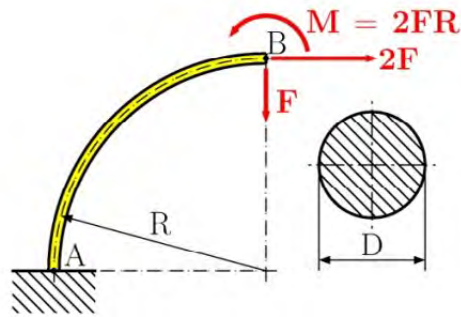


Fig. 4.79

For the curved beam in Fig. 4.79 determine: (a) the equation defining the transversal and normal (axial) load and bending moment at any point, (b) location of the maximum bending moment, maximum transversal load and maximum normal load (c) draw the normal load, transversal load, and bending moment diagram and check a given cross-section area in critical points using von Mises criterion.

**Solution**

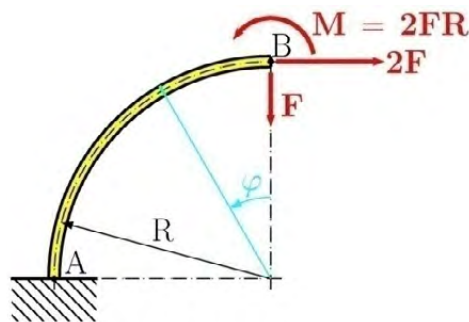


Fig. 4.80

$$\varphi \in \langle 0, \pi/2 \rangle$$

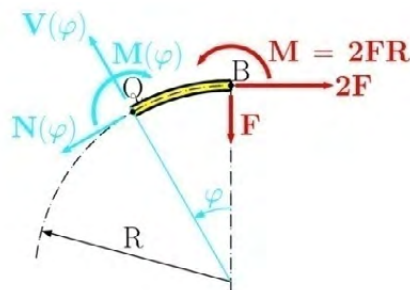


Fig. 4.81

(a) the equation defining the transversal load, normal (axial) load and bending moment at any point

Starting from the free end at point B we can define, in cylindrical coordinates, the angle  $\varphi$ . The bending moment in position j at point Q, seen in Fig 4.81 and Fig. 4.83, we find the moment equilibrium at point Q which is

$$\sum M_{iQ} = 0: -M(\varphi) + M - FR \sin \varphi - 2FR(1 - \cos \varphi) = 0$$

$$M(\varphi) = 2FR \cos \varphi - FR \sin \varphi$$

We find the normal and transversal loads at point Q from the decomposition of all forces to the new coordinate system  $x'y'$  in Fig. 4.82. We write the equilibrium equations for the force in the  $x'$  direction

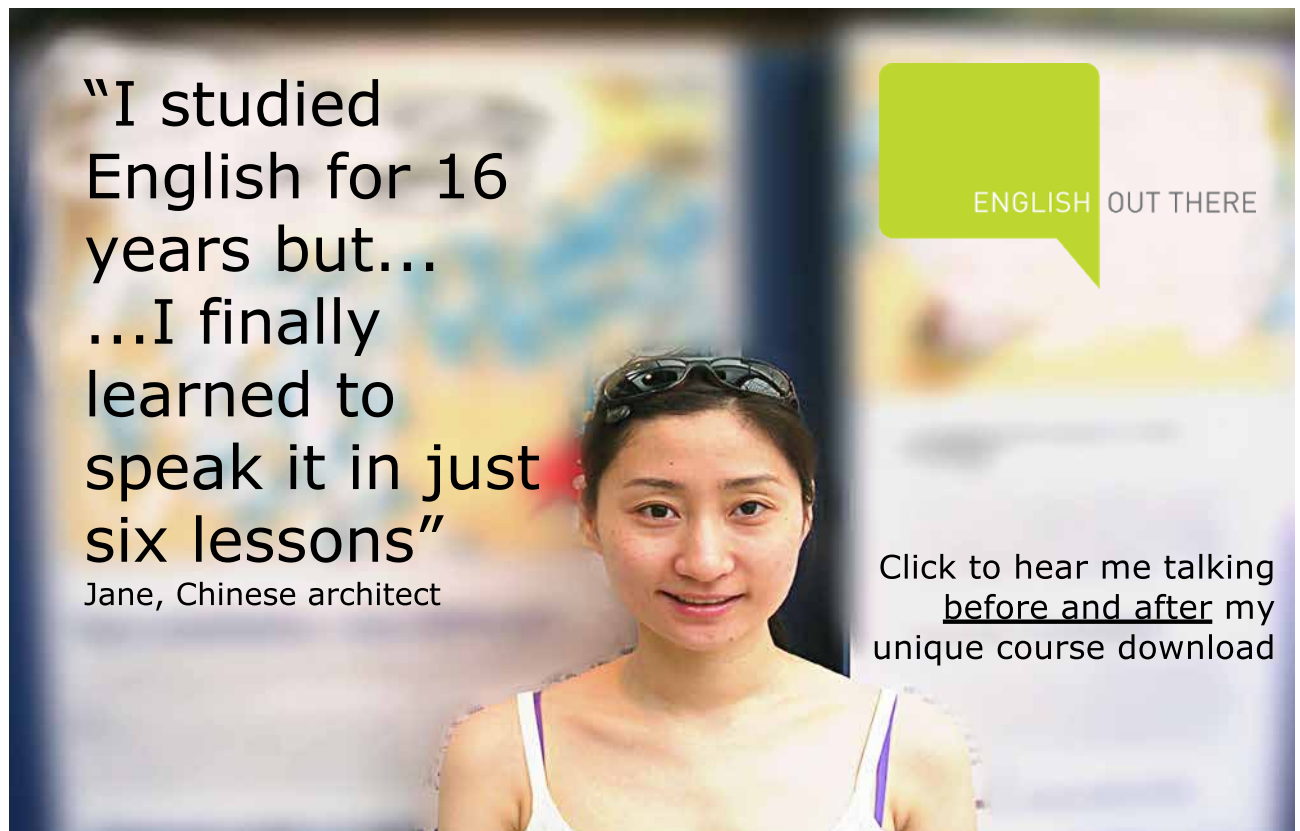
$$\sum F_{ix'} = 0: -N(\varphi) - F \sin \varphi + 2F \cos \varphi = 0$$

from which we have a normal force

$$N(\varphi) = -F \sin \varphi + 2F \cos \varphi.$$

The equilibrium equation in the  $y'$  direction is

$$\sum F_{iy'} = 0: V(\varphi) - F \cos \varphi - 2F \sin \varphi = 0$$



"I studied English for 16 years but...  
...I finally learned to speak it in just six lessons"  
Jane, Chinese architect

ENGLISH OUT THERE

Click to hear me talking before and after my unique course download

from which we have a transversal load

$$V(\varphi) = F \cos \varphi + 2F \sin \varphi .$$

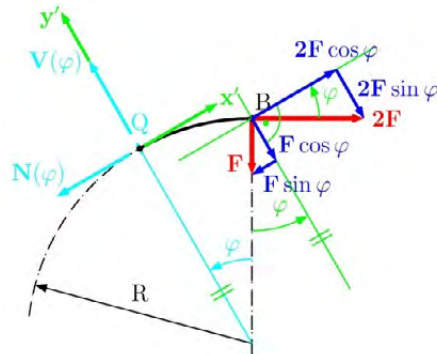


Fig. 4.82

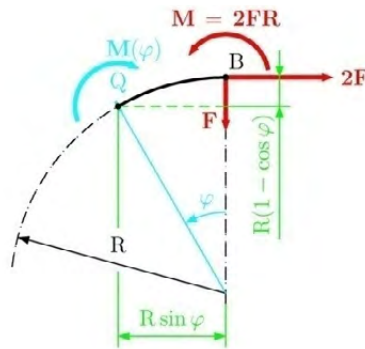


Fig. 4.83

- (b) location of the maximum bending moment, maximum transversal load, maximum normal load, and  
 (c) draw the normal and transversal load and bending moment diagram

The graphical presentations of the results are shown in Fig. 4.84. From these diagrams we have two locations which have maximum values (point I and II).

at location  $\varphi = 0$  (point I) we have

$$M_{\max} = M(\varphi = 0) = 2FR$$

$$N_{\max} = N(\varphi = 0) = 2F$$

$$V(\varphi = 0) = F$$

at location  $\varphi = \pi/2$  (point II) we have

$$M(\varphi = \pi/2) = -FR$$

$$N(\varphi = \pi/2) = -F$$

$$V_{\max} = V(\varphi = \pi/2) = 2F$$

(c) check a given cross-section area in critical points using von Mises criterion

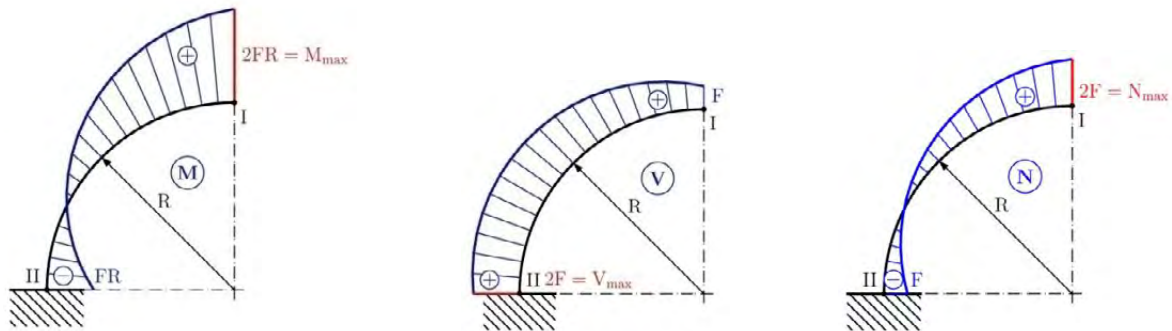


Fig. 4.84

*Design of cross-section area in point I.*

The maximum bending stress is

$$\sigma_{\max} = \frac{|M_{\max}|}{S} = \frac{|M_{\max}|}{I_z} y_{\max} = \frac{|M_{\max}|}{\pi D^4} \frac{D}{2} = \frac{32 |M_{\max}|}{\pi D^3}$$

$$\sigma_{\max} = \frac{32 |-FR|}{\pi D^3} = \frac{32 FR}{\pi D^3}$$

The shearing stress is (see, Timoshenko et al)

$$\tau_{\max} = \frac{|V|Q}{t I_z} = \frac{4 V}{3 A} = \frac{4}{3} \frac{2F}{\pi D^2} = \frac{32}{3} \frac{F}{\pi D^2},$$

and the normal stress is

$$\sigma_N = \frac{|N|}{A} = \frac{|N|}{\pi D^2} = \frac{4 |-F|}{\pi D^2} = \frac{4F}{\pi D^2}.$$

A diagram of the bending, normal and shearing stress can be seen in Fig. 4.85.

Von Mises stress at point 2 is

$$\sigma_{\text{Mises}} = \sqrt{(\sigma_{\text{max}} - \sigma_{\text{N}})^2 + 3 \times 0^2} = |\sigma_{\text{max}} - \sigma_{\text{N}}|$$

$$\sigma_{\text{Mises}} = \left| \frac{64FR}{\pi D^3} + \frac{8F}{\pi D^2} \right| \leq \sigma_{\text{all}}$$

Note that, in this point we have a different sign for the bending and normal stress.

Von Mises stress at point 4 is

$$\sigma_{\text{Mises}} = \sqrt{(\sigma_{\text{max}} + \sigma_{\text{N}})^2 + 3 \times 0^2} = |\sigma_{\text{max}} + \sigma_{\text{N}}|$$

$$\sigma_{\text{Mises}} = \left| \frac{64FR}{\pi D^3} - \frac{8F}{\pi D^2} \right| \leq \sigma_{\text{all}}$$

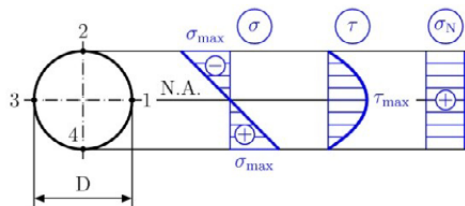


Fig. 4.85

Note that, in this point we have the same sign for the bending and normal stress.

At point 1 and 3 from Fig. 4.85 we get

$$\sigma_{\text{Mises}} = \sqrt{\sigma_{\text{N}}^2 + 3\tau_{\text{max}}^2} = \sqrt{\left(\frac{8F}{\pi D^2}\right)^2 + 3\left(\frac{16}{3} \frac{F}{\pi D^2}\right)^2} \leq \sigma_{\text{all}}$$

*Design of cross-section area in point II.*

The maximum bending stress is

$$\sigma_{\text{max}} = \frac{|M_{\text{max}}|}{S} = \frac{|M_{\text{max}}|}{I_z} y_{\text{max}} = \frac{|M_{\text{max}}|}{\frac{\pi D^4}{64}} \frac{D}{2} = \frac{32|M_{\text{max}}|}{\pi D^3}$$

$$\sigma_{\max} = \frac{32|-FR|}{\pi D^3} = \frac{32FR}{\pi D^3}$$

The shearing stress is (see, Timoshenko et al)

$$\tau_{\max} = \frac{|V|Q}{t I_z} = \frac{4}{3} \frac{V}{A} = \frac{4}{3} \frac{2F}{\pi D^2} = \frac{32}{3} \frac{F}{\pi D^2},$$

and the normal stress is

$$\sigma_N = \frac{|N|}{A} = \frac{|N|}{\pi D^2} = \frac{4|-F|}{\pi D^2} = \frac{4F}{\pi D^2}.$$

The bending, normal and shearing stress diagram can be seen in Fig. 4.86.

**wethrive.net**

**How to retain your top staff**

**FIND OUT NOW FOR FREE**

**DO YOU WANT TO KNOW:**

- What your staff really want?
- The top issues troubling them?
- How to make staff assessments work for you & them, painlessly?

**Get your free trial**

Because happy staff get more done

The Von Mises stress at point 2 is

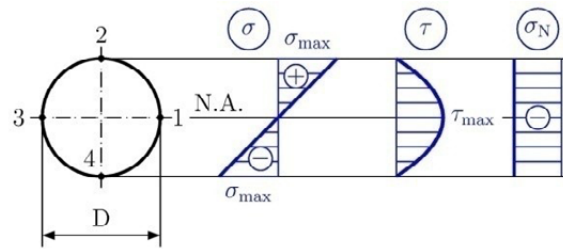


Fig. 4.86

$$\sigma_{\text{Mises}} = \sqrt{(\sigma_{\text{max}} - \sigma_{\text{N}})^2 + 3 \times 0^2} = |\sigma_{\text{max}} - \sigma_{\text{N}}|$$

$$\sigma_{\text{Mises}} = \left| \frac{32FR}{\pi D^3} - \frac{4F}{\pi D^2} \right| \leq \sigma_{\text{all}}$$

Note that, in this point, we have a different sign for the bending and normal stress.

The Von Mises stress at point 4 is

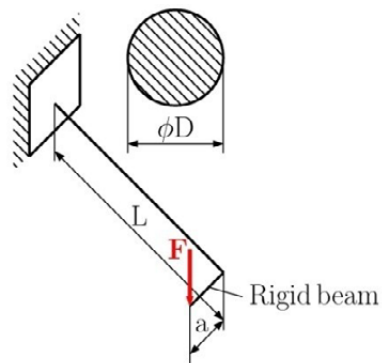
$$\sigma_{\text{Mises}} = \sqrt{(\sigma_{\text{max}} + \sigma_{\text{N}})^2 + 3 \times 0^2} = |\sigma_{\text{max}} + \sigma_{\text{N}}|$$

$$\sigma_{\text{Mises}} = \left| \frac{32FR}{\pi D^3} + \frac{4F}{\pi D^2} \right| \leq \sigma_{\text{all}}$$

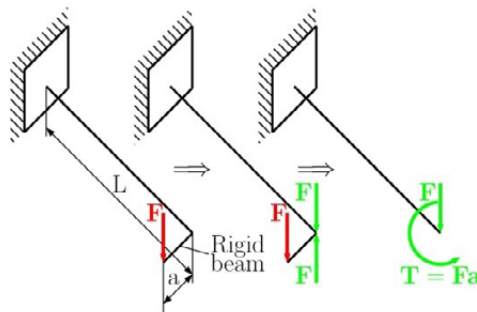
Note that, In this point, we have the same sign for the bending and normal stress.

At point 1 and 3 from Fig. 4.86 we get

$$\sigma_{\text{Mises}} = \sqrt{\sigma_{\text{N}}^2 + 3\tau_{\text{max}}^2} = \sqrt{\left(\frac{4F}{\pi D^2}\right)^2 + 3\left(\frac{32}{3} \frac{F}{\pi D^2}\right)^2} \leq \sigma_{\text{all}}$$

**Problem 4.7****Fig. 4.87**

For the beam in Fig. 4.87 determine the maximum values of bending moment, torque, and transversal load. Draw the diagram of bending moment, torque and transversal load and check the circular cross-section for strength using Mises criterion. The length  $L$ ,  $a$ , diameter  $D$ , force  $F$ , and allowable stress  $\sigma_{\text{all}}$  are given.

**Solution****Fig. 4.88**

The equivalent force system is determined by the torque  $T$  and the transversal load  $F$  shown in Fig. 4.88. After this transformation we have a cantilever beam, which has a  $T = Fa$  and force  $F$  at its free end, see Fig. 4.89 (last view).

This problem is a combination of torsion and bending. The solution is to divide the problem into two parts, the torsion solution and bending solution. Then we sum the results from both parts.

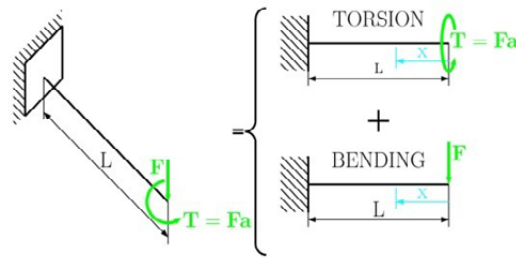


Fig. 4.89

*Solution for torsion* (see chapter 3 Torsion)

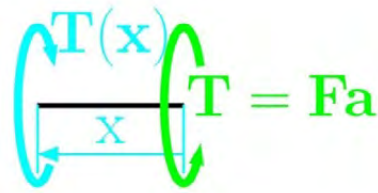
We solve for the part with length  $x$ , see Fig. 4.90, where, in the cutting plane area, we assign the positive torque moment  $T(x)$ . The value of  $T(x)$  is found from the equilibrium equation of moment about the  $x$  axis, which is

**gaiteye**  
Challenge the way we run

**EXPERIENCE THE POWER OF FULL ENGAGEMENT...**

**RUN FASTER.  
RUN LONGER..  
RUN EASIER...**

**READ MORE & PRE-ORDER TODAY  
WWW.GAITEYE.COM**



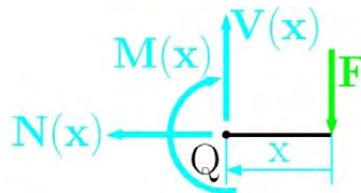
$$x \in \langle 0, L \rangle$$

Fig. 4.90

$$\sum M_{ix} = 0: T(x) - T = 0$$

$$T(x) = T = Fa$$

The torque diagram along the length of the beam can be seen in Fig. 4.93.



$$x \in \langle 0, L \rangle$$

Fig. 4.91

*Solution for bending.*

For the part of the beam at length  $x$  and with internal forces and moment at point  $Q$ , see Fig. 4.91. We find the bending moment from the equilibrium equation

$$\sum M_{iQ} = 0: -M(x) - F x = 0$$

$$M(x) = -F x,$$

transversal load

$$\sum F_{iy} = 0: V(x) - F = 0$$

$$V(x) = F,$$

and normal (axial) load

$$\sum F_{ix} = 0: N(x) = 0.$$

The bending moment and transversal load diagrams are shown in Fig. 4.92.

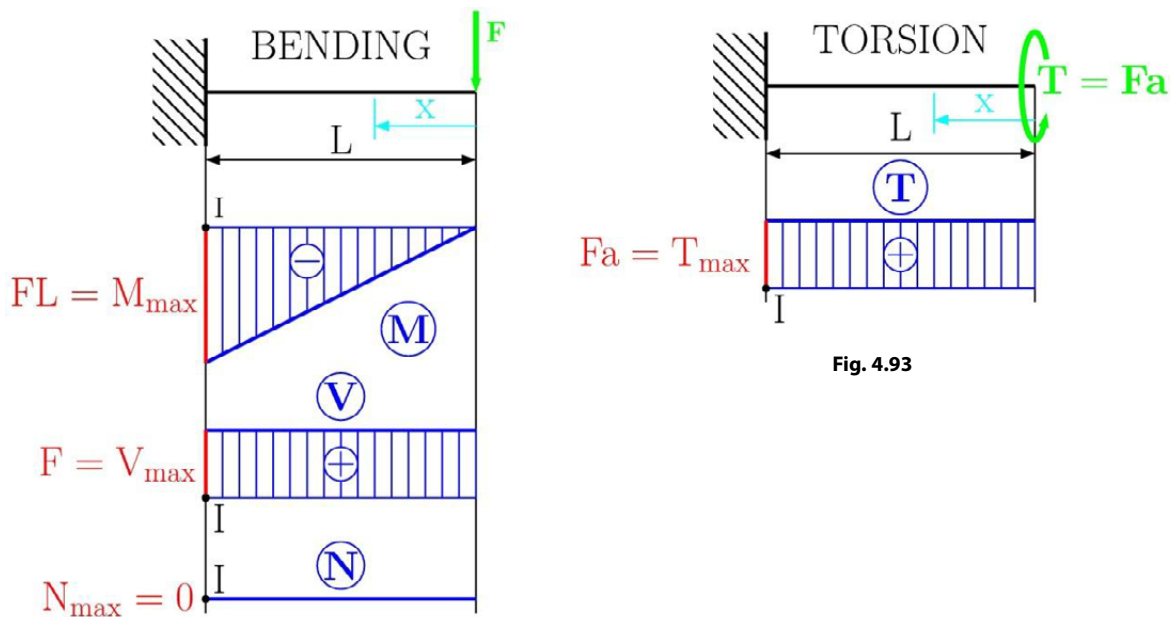


Fig. 4.92

Fig. 4.93

Check of the circular cross-section.

The maximum bending stress is

$$\sigma_{\max} = \frac{|M_{\max}|}{S} = \frac{|M_{\max}|}{I_z} y_{\max} = \frac{|M_{\max}| D}{\frac{\pi D^4}{64} \cdot 2} = \frac{32 |M_{\max}|}{\pi D^3}$$

$$\sigma_{\max} = \frac{32 |-FL|}{\pi D^3} = \frac{32 FL}{\pi D^3}$$

The shearing stress is (see, Timoshenko et al)

$$\tau_{\max} = \frac{|V| Q}{t I_z} = \frac{4 V}{3 A} = \frac{4 F}{3 \frac{\pi D^2}{4}} = \frac{16 F}{3 \pi D^2},$$

and the maximum shearing stress in torsion is (from chapter 3)

$$\tau_{T \max} = \frac{|T|}{J} \rho_{\max} = \frac{|T| D}{J} \frac{D}{2} = \frac{|T| D}{\pi D^4} \frac{D}{2}$$

$$\tau_{T \max} = \frac{16 T}{\pi D^3}$$

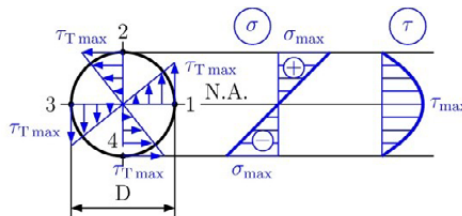


Fig. 4.94

The bending, normal, and shearing stress diagrams are shown in Fig. 4.94.

This e-book  
is made with  
**SetaPDF**



PDF components for PHP developers

[www.setasign.com](http://www.setasign.com)



The Von Mises stress at point 2 and 4 is

$$\sigma_{\text{Mises}} = \sqrt{\sigma_{\text{max}}^2 + 3\tau_{\text{Tmax}}^2}$$

$$\sigma_{\text{Mises}} = \sqrt{\left(\frac{32 FL}{\pi D^3}\right)^2 + 3\left(\frac{16 T}{\pi D^3}\right)^2} \leq \sigma_{\text{all}}$$

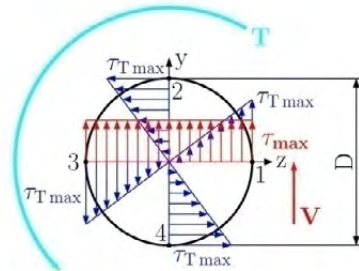


Fig. 4.95

At point 1, the shearing stress from the transversal load and torque are in the same directions (see Fig. 4.95), and we get

$$\sigma_{\text{Mises}} = \sqrt{\sigma^2 + 3(\tau_{\text{max}} + \tau_{\text{Tmax}})^2} = \sqrt{0^2 + 3(\tau_{\text{max}} + \tau_{\text{Tmax}})^2}$$

$$\sigma_{\text{Mises}} = \sqrt{3} |\tau_{\text{max}} + \tau_{\text{Tmax}}|$$

$$\sigma_{\text{Mises}} = \sqrt{3} \left| \frac{16}{3} \frac{F}{\pi D^2} + \frac{16 T}{\pi D^3} \right| \leq \sigma_{\text{all}}$$

At point 3 the shearing stress from the transversal load and torque are in the opposite directions (see Fig. 4.95), we get

$$\sigma_{\text{Mises}} = \sqrt{\sigma^2 + 3(\tau_{\text{max}} - \tau_{\text{Tmax}})^2} = \sqrt{0^2 + 3(\tau_{\text{max}} - \tau_{\text{Tmax}})^2}$$

$$\sigma_{\text{Mises}} = \sqrt{3} |\tau_{\text{max}} - \tau_{\text{Tmax}}|$$

$$\sigma_{\text{Mises}} = \sqrt{3} \left| \frac{16}{3} \frac{F}{\pi D^2} - \frac{16 T}{\pi D^3} \right| \leq \sigma_{\text{all}}$$

Unsolved problems

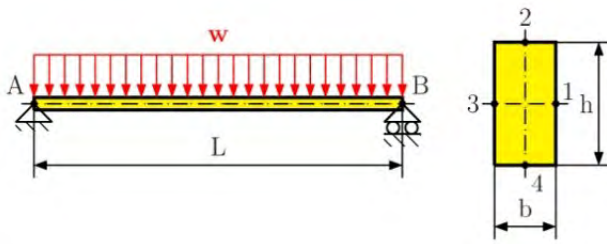


Fig. 4.96

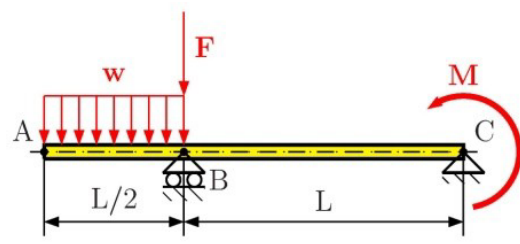


Fig. 4.97

Problem 4.8

For the beam in Fig. 4.96, Determine (a) the equation of the transversal and bending curve, (b) the absolute maximum value of the bending moment and transversal load in the beam, (c) the Von Mises stress for the rectangular cross-section area at point 1, 2, 3 and 4 at the position of the maximum bending moment. Assume that  $L = 500 \text{ mm}$ ,  $w = 12 \text{ kN/m}$ ,  $b = 20 \text{ mm}$  and  $h = 30 \text{ mm}$ .

$$[R_{Ax} = 0 \text{ N}, R_A = 3000 \text{ N}, R_B = 3000 \text{ N}, M_{\max} = 375 \text{ Nm}, V_{\max} = 3000 \text{ N}, \sigma_{\text{Mises } 1} = \sigma_{\text{Mises } 3} = 0 \text{ MPa}, \sigma_{\text{Mises } 2} = \sigma_{\text{Mises } 4} = 125 \text{ MPa}]$$



Discover the truth at [www.deloitte.ca/careers](http://www.deloitte.ca/careers)

**Deloitte.**

© Deloitte & Touche LLP and affiliated entities.



**Problem 4.9**

For the beam in Fig. 4.97, which has a length  $L = 300$  mm and is loaded by the uniform load  $w = 5$  kN/m, force  $F = 1.2$  kN applied at point B and bending moment  $M = 1.5$  kNm at point C, determine (a) the maximum absolute value of the bending moment and transversal load, (b) design the diameter  $D$  of the circular cross-section area for the given allowable stress of 250 MPa. The beam has a circular cross-section area along its whole length.

$$[R_{Bx} = 0 \text{ N}, R_{By} = 5187.5 \text{ N}, R_A = 7137.5 \text{ N}, M_{\max} = 1500 \text{ Nm}, V_{\max} = 5187.5 \text{ N}, D \geq 39.4 \text{ mm}]$$

**Problem 4.10**

For the curved beam in Fig. 4.98 determine (a) the reaction at the supports (b) the maximum absolute value of the bending moment, transversal and normal load, (c) design the rectangular cross-section area with a width  $b$  and height  $h$ , when the ratio between  $h / b = 2$  for a given allowable stress  $\sigma_{\text{all}}$ . For the solution used the parameters  $R = 1$  m,  $M = 0.5$  kNm, and  $\sigma_{\text{all}} = 150$  MPa.

$$[R_{Ax} = 0 \text{ N}, R_A = 803.85 \text{ N}, R_B = 803.85 \text{ N}, M_{\max} = 696.15 \text{ Nm}, \\ V_{\max} = 803.85 \text{ N}, N_{\max} = 803.85 \text{ N}, b \geq 17.1 \text{ mm}]$$

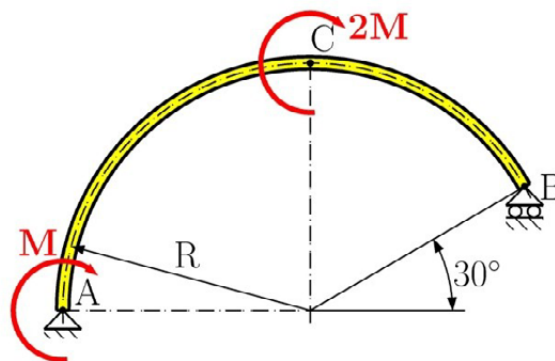


Fig. 4.98

# 5 Deflection of Beams

## 5.1 Introduction

In the previous Section we talked about the stress and strain analyses of beams under transverse loading. Safe design requires that we satisfy not only the strength criteria but also the deformation response. The deformation response involves the acceptable strains, deflections and slopes which fit the requirements of the structure. Deriving the formula for calculating the radius of curvature of the neutral surface we have

$$\frac{1}{\rho} = \frac{M(x)}{EI} \quad (5.1)$$

This equation is valid if Saint Venant's principle is satisfied for a beam transversely loaded. The bending moment varies from section to section and therefore the curvature of the neutral surface will vary as well.

This will constitute the basis for the integration method used to calculate deflections and slopes. There are several other methods based on different approaches like the energy method (Castigliano's theorem). Both methods are discussed in this Chapter.

## 5.2 Integration method

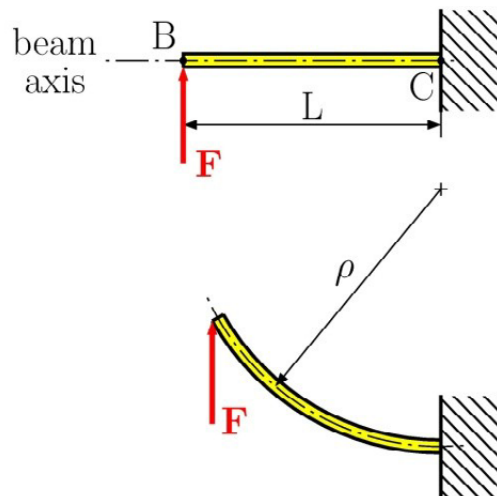


Fig. 5.1 Cantilever beam

Equation (5.1) represents information about the shape of the deformed beam only, for example consider the cantilever beam  $BC$  of length  $L$  acted on by the applied load  $F$ , see Fig. 5.1. Usually the analysis and design of such a beam would require more precise information about the beam's deformation, i.e. detailed information about *the deflection* and *the slope* at various points of the beam. The problem of calculating *the maximum deflection* has particular importance in beam design. Therefore our task is to find any relation between the position of an arbitrary point, determined by the distance  $x$  from the end of the beam, and the deflection  $y$  measured from the axis of the undeformed beam at this point, see Fig 5.2.

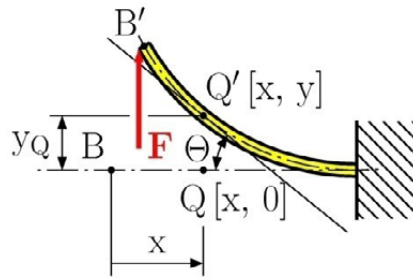


Fig. 5.2

From mathematics we get the curvature at point  $Q'[x, y]$  to be

$$\frac{1}{\rho} = \frac{\frac{d^2y}{dx^2}}{\left(1 + \left(\frac{dy}{dx}\right)^2\right)^{\frac{3}{2}}} \tag{5.2}$$

where  $dy/dx$  and  $d^2y/dx^2$  are the first and second derivatives of the function  $y(x)$  representing the elastic curve. Assuming the elastic response to loading, we can expect a very small value of beam slope  $\theta(x)=dy/dx$  and its square is negligible compared to unity. Thus we get

$$\frac{d^2y}{dx^2} = \frac{M(x)}{EI} \tag{5.3}$$

© 2013 Accenture. All rights reserved.

be > your degree

Bring your talent and passion to a global organization at the forefront of business, technology and innovation. Discover how great you can be.

Visit [accenture.com/bookboon](http://accenture.com/bookboon)

Be greater than.  
consulting | technology | outsourcing

accenture  
High performance. Delivered.



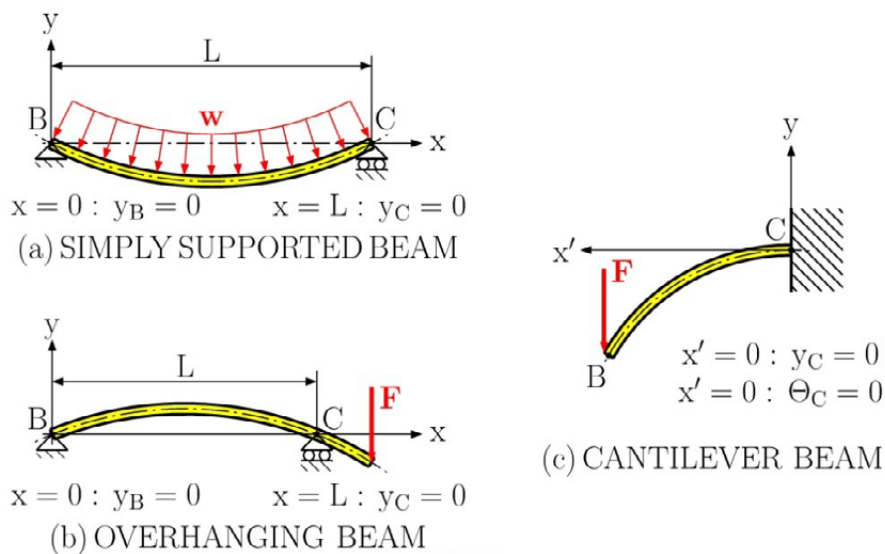
The equation obtained is a second-order linear differential equation; it is the governing differential equation for the *elastic curve*. Using the double integration in  $x$  for this differential equation we will obtain the elastic curve. For the prismatic beam we can consider the constant *flexural rigidity*  $EI$  so we have

$$EI \frac{dy}{dx} = EI\theta(x) = \int_0^x M(x) dx + C_1 \quad (5.4)$$

where  $C_1$  is the integration constant. By integrating the above equation we obtain

$$EIy(x) = \int_0^x \left[ \int_0^x M(x) dx + C_1 \right] dx + C_2$$

$$EIy(x) = \int_0^x \left[ \int_0^x M(x) dx \right] dx + C_1 x + C_2$$



**Fig. 5.3** Boundary conditions

where  $C_2$  is also an integration constant. With respect to mathematics we get an infinite number of solutions. To obtain the solution for the beam considered we need to apply *boundary conditions*, or more precisely, from the conditions imposed on the beam by its supports. In this Section we will limit ourselves to *statically determinate beams*, i.e. the corresponding reactions can be determined by methods of statics directly. Possible boundary conditions are presented in Fig. 5.3.

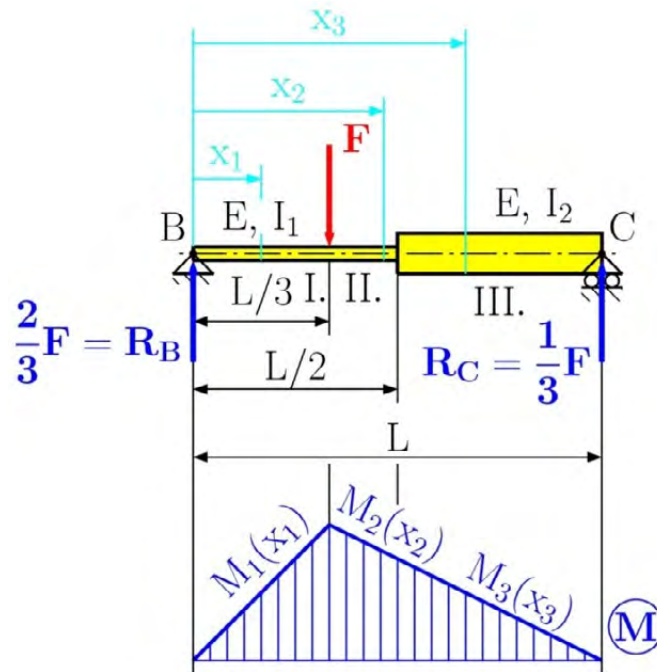


Fig. 5.4 Simply supported beam

The problem of searching for the maximum deflection can be mathematically formulated as the problem of searching for the maximum value within the interval. For example in Fig. 5.1 the maximum deflection is at the free end of the cantilever beam.

Let us consider the simply supported beam  $BC$  of length  $L$ , see Fig. 5.4. Our task is to calculate the deflection at point  $D$ . The solution can be obtained using the step-by-step approach, see Chapter 1. Thus we get  $R_B = \frac{2}{3}F$  and  $R_C = \frac{1}{3}F$ . The beam has three homogeneous parts due to the load and sections. For each part one can easily determined the bending moment distribution functions as follows

$$M_1(x_1) = R_B x_1 = \frac{2}{3}F x_1 \quad 0 \leq x_1 \leq \frac{L}{3}$$

$$M_2(x_2) = R_B x_2 - F(x_2 - L) = \frac{1}{3}F(L - x_2) \quad \frac{L}{3} \leq x_2 \leq \frac{L}{2}$$

$$M_3(x_3) = R_B x_3 - F(x_3 - L) = \frac{1}{3}F(L - x_3) \quad \frac{L}{2} \leq x_3 \leq L$$

Subsequently we get three differential equations using equation (5.3) because this is not the case of the prismatic beam, then

$$\frac{d^2 y_1}{dx_1^2} = \frac{M_1(x_1)}{EI_1} \quad ; \quad \frac{d^2 y_2}{dx_2^2} = \frac{M_2(x_2)}{EI_1} \quad ; \quad \frac{d^2 y_3}{dx_3^2} = \frac{M_3(x_3)}{EI_2}$$

Integration of the above equations we get

$$y_1 = \frac{F}{9EI_1} x_1^3 + C_1 x_1 + C_2 \quad y_2 = \frac{FL}{6EI_1} x_2^2 + \frac{F}{18EI_1} x_2^3 + C_3 x_2 + C_4$$

$$y_3 = \frac{FL}{6EI_2} x_3^2 + \frac{F}{18EI_2} x_3^3 + C_5 x_3 + C_6$$

For this problem we get six integration constants. Therefore we need boundary conditions

$$x_1 = 0 \quad y_1(0) = 0; \quad x_3 = L \quad y_3(L) = 0$$

*the connectivity conditions* between parts of the beam

$$x_1 = x_2 = \frac{L}{3} \quad y_1\left(\frac{L}{3}\right) = y_2\left(\frac{L}{3}\right); \quad x_2 = x_3 = \frac{L}{2} \quad y_2\left(\frac{L}{2}\right) = y_3\left(\frac{L}{2}\right);$$

$$x_1 = x_2 = \frac{L}{3} \quad \theta_1\left(\frac{L}{3}\right) = \theta_2\left(\frac{L}{3}\right); \quad x_2 = x_3 = \frac{L}{2} \quad \theta_2\left(\frac{L}{2}\right) = \theta_3\left(\frac{L}{2}\right);$$

Solving the boundary and connectivity conditions we can get the integration constants as follows

$$C_1 = -\frac{FL^2}{648EI_1I_2} (9I_1 + 31I_2)$$

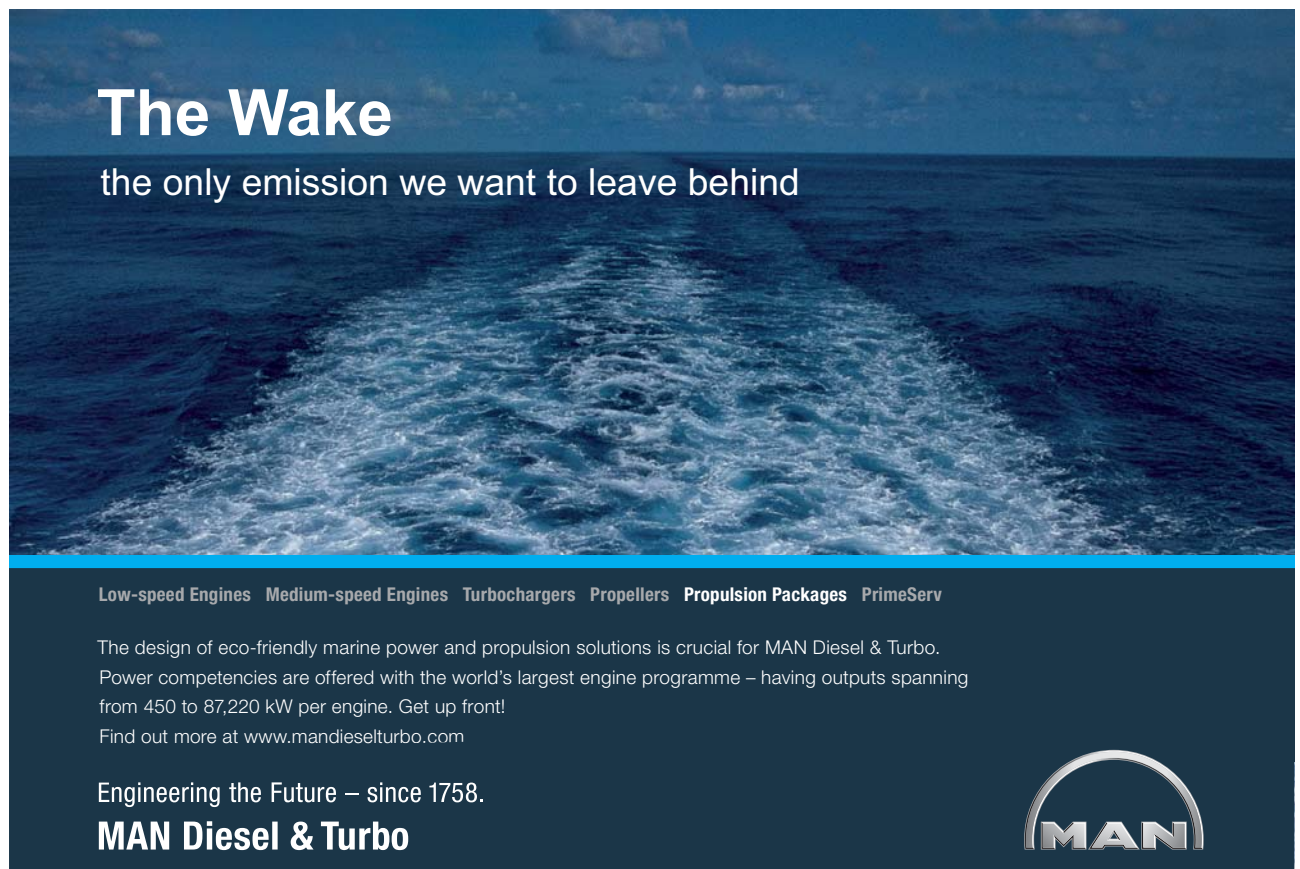
$$C_2 = 0$$

$$C_3 = -\frac{FL^2}{648EI_1I_2} (9I_1 + 67I_2)$$

$$C_4 = -\frac{FL^3}{162EI_1}$$

$$C_5 = -\frac{FL^2}{648EI_1I_2} (90I_1 - 14I_2)$$

$$C_6 = -\frac{FL^3}{648EI_1I_2} (14I_2 - 18I_1)$$




**The Wake**  
the only emission we want to leave behind

Low-speed Engines Medium-speed Engines Turbochargers Propellers **Propulsion Packages** PrimeServ

The design of eco-friendly marine power and propulsion solutions is crucial for MAN Diesel & Turbo. Power competencies are offered with the world's largest engine programme – having outputs spanning from 450 to 87,220 kW per engine. Get up front! Find out more at [www.mandieselturbo.com](http://www.mandieselturbo.com)

Engineering the Future – since 1758.  
**MAN Diesel & Turbo**



Click on the ad to read more

Then substituting the integration constants and  $x_1 = \frac{L}{3}$  into the elastic curve of the first part, the deflection at point  $D$  becomes

$$y_1\left(\frac{L}{3}\right) = y_D = -\frac{FL^3}{1944EI_1I_2}(9I_1 + 23I_2)$$

For the prismatic beam  $I_1 = I_2 = I$  we will get a solution of  $y_1\left(\frac{L}{3}\right) = y_D = -\frac{4FL^3}{243EI}$ .

### 5.3 Using a Singularity Function to Determine the Slope and Deflection of Beams

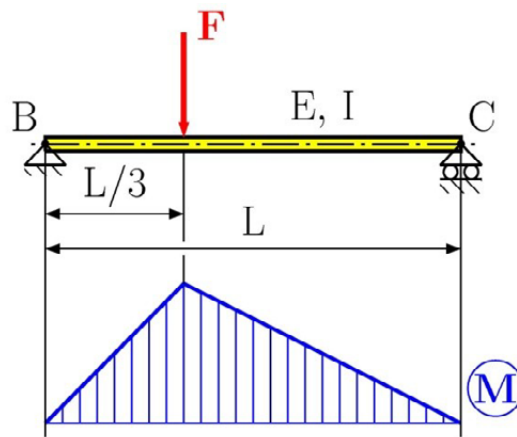


Fig. 5.5 Prismatic simply supported beam

As we discussed before in Chapter 4, the application of singularity functions is a very progressive methodology. The method can be applied for prismatic beams only. Let us apply the singularity function a modification of the previous example that has constant flexural rigidity, see Fig. 5.5. We can then write the bending moment

$$M(x) = R_B x - F \left\langle x - \frac{L}{3} \right\rangle \quad (5.5)$$

Then we have

$$EIy(x) = R_B \frac{x^3}{6} - F \frac{\langle x - \frac{L}{3} \rangle^3}{6} + C_1 x + C_2 \quad (5.6)$$

after integrating we obtain

$$EIy(x) = R_B \frac{x^3}{6} - F \frac{\langle x - \frac{L}{3} \rangle^3}{6} + C_1 x + C_2 \quad (5.7)$$

This equation contains only two integration constants that can be determined from boundary conditions

$$x = 0 \quad y(0) = 0; \quad x = L \quad y(L) = 0$$

or

$$0 = R_B \cdot 0 - F \cdot 0 + C_1 \cdot 0 + C_2; \quad 0 = R_B \cdot L - F \cdot \frac{(L-\frac{L}{3})^3}{6} + C_1 L + C_2$$

Solving these boundary conditions, we get the integration constants  $C_1 = -\frac{5FL^2}{81}$  and  $C_2 = 0$  and subsequently we can determine the deflection at point  $D$ ,  $y\left(\frac{L}{3}\right) = y_D = -\frac{4FL^3}{243EI}$ .

The reduction of the number of integration constants is a great advantage of using singularity functions.

#### 5.4 Castigliano's Theorem

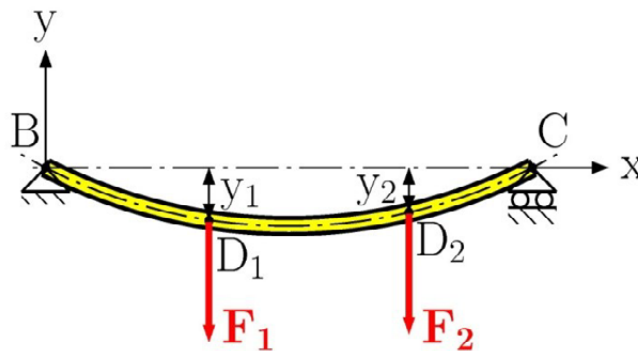


Fig. 5.6

Let us consider the simply supported beam  $BC$  of length  $L$  acted on by two concentrated forces  $F_1$  and  $F_2$  at points  $D_1$  and  $D_2$ , see Fig. 5.6. The strain energy accumulated in the beam is equal to the work done by the applied forces since they are applied slowly. To evaluate this work we need to first express the deflections  $y_1$  and  $y_2$  in terms of the loads  $F_1$  and  $F_2$ .

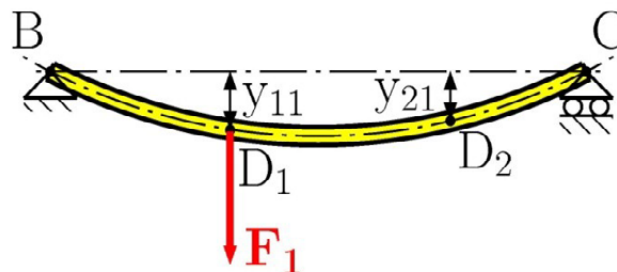


Fig. 5.7

Let us assume that only  $F_1$  is applied to the beam, see Fig. 5.7. The deflection at both points is proportional to the applied load  $F_1$ . Denoting these deflections by  $y_{11}$  and  $y_{21}$  we have

$$y_{11} = \alpha_{11}F_1 \quad \text{and} \quad y_{21} = \alpha_{21}F_1 \quad (5.8)$$

where  $\alpha_{11}$  and  $\alpha_{21}$  are *the influence coefficients*. These constants represent the deflection at points  $D_1$  and  $D_2$ .

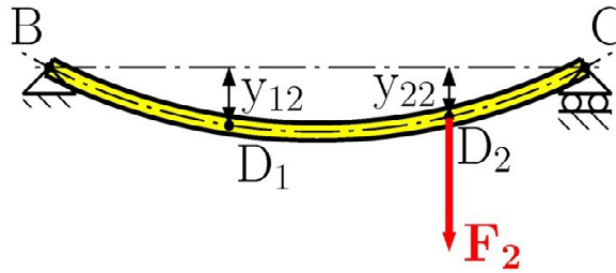


Fig. 5.8

Now we apply the load  $F_2$  separately to the beam, see Fig. 5.8. Denoting deflections at points  $D_1$  and  $D_2$  by  $y_{12}$  and  $y_{22}$  we have

$$y_{12} = \alpha_{12}F_2 \quad \text{and} \quad y_{22} = \alpha_{22}F_2 \quad (5.9)$$

## SMS from your computer

...Sync'd with your Android phone & number

**FREE**  
30 days trial!

Go to

BrowserTexting.com

and start texting from your computer!

**BrowserTexting**

**Click on the ad to read more**

Applying the principle of superposition we get the total deflection at these points as follows

$$\begin{aligned} y_1 &= y_{11} + y_{12} = \alpha_{11}F_1 + \alpha_{12}F_2 \\ y_2 &= y_{21} + y_{22} = \alpha_{21}F_1 + \alpha_{22}F_2 \end{aligned} \tag{5.10}$$

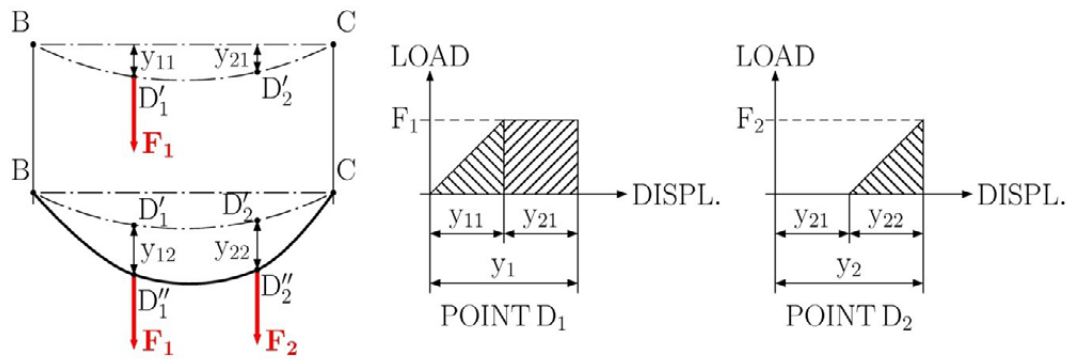


Fig. 5.9

To compute the work done by forces  $F_1$  and  $F_2$  and thus the strain energy of the beam, it is convenient to apply the force  $F_1$  first and then to add the force  $F_2$  after, see Fig. 5.9. Then we have

$$W = U = \frac{1}{2}F_1y_{11} + F_1y_{12} + \frac{1}{2}F_2y_{22} = \frac{1}{2}\alpha_{11}F_1^2 + \alpha_{12}F_1F_2 + \frac{1}{2}\alpha_{22}F_2^2 \tag{5.11}$$

If the load  $F_2$  had been applied first and then the load  $F_1$ , the work done by those forces would be calculated as

$$W = U = \frac{1}{2}F_1y_{11} + F_2y_{21} + \frac{1}{2}F_2y_{22} = \frac{1}{2}\alpha_{11}F_1^2 + \alpha_{21}F_1F_2 + \frac{1}{2}\alpha_{22}F_2^2 \tag{5.12}$$

This can be illustrated in Fig. 5.10. Comparing equations (5.11) and (5.12) we get  $\alpha_{12} = \alpha_{21}$ .

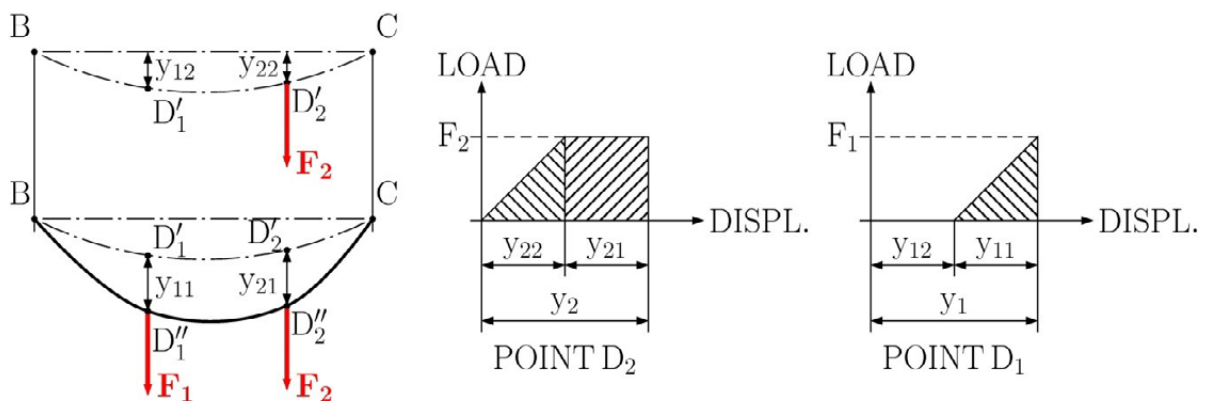


Fig. 5.10

Thus we can conclude that the deflection produced at  $D_1$  by the unit load applied at  $D_2$  is equal to the deflection produced at  $D_2$  by the unit load applied at  $D_1$ . This is known as *Maxwell's reciprocal theorem* (Maxwell 1831–1879).

Now differentiating equation (5.11) with respect to  $F_1$  we get

$$\frac{\partial U}{\partial F_1} = \alpha_{11}F_1 + \alpha_{12}F_2 = y_1 \quad (5.13)$$

Differentiating equation (5.11) with respect to  $F_2$ , while keeping in mind that  $\alpha_{12} = \alpha_{21}$ , we obtain

$$\frac{\partial U}{\partial F_2} = \alpha_{12}F_1 + \alpha_{22}F_2 = y_2 \quad (5.13)$$

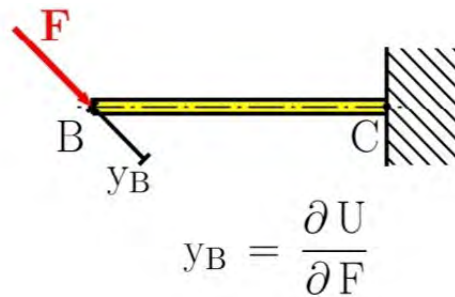


Fig. 5.11

The physical meaning of the last equations is that, the deflection or the displacement of the applied load point is in the direction of the applied load and is equal to the partial derivative of the strain energy with respect to the applied load, see Fig. 5.11, namely

$$\frac{\partial U}{\partial F} = y_B \quad (5.14)$$

This is the well-known *Castigliano's theorem*, (Castigliano 1847–1884). This formulation can be extended to the applied bending couple  $M$  and torque  $T$ , i.e.

$$\frac{\partial U}{\partial M} = \theta \quad \text{and} \quad \frac{\partial U}{\partial T} = \varphi \quad (5.15)$$

We need to emphasise that Castigliano's theorem can only be used for calculating the deflection  $y$ , the slope,  $\theta$  or the angle of twist  $\varphi$  at the points where the concentrated forces or bending couples (torques) are acting.

## 5.5 Deflections by Castigliano's Theorem

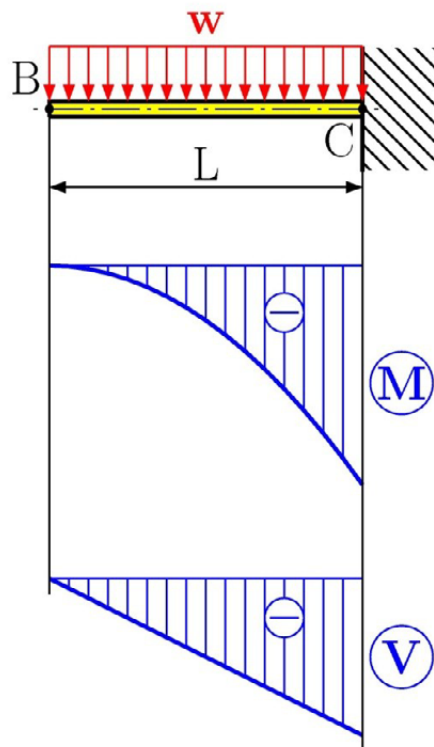
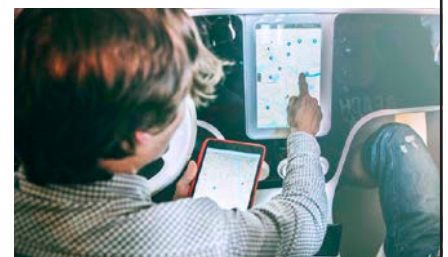


Fig. 5.12

YOUR WORK AT TOMTOM WILL  
BE TOUCHED BY MILLIONS.  
**AROUND THE WORLD.** EVERYDAY.

Join us now on [www.TomTom.jobs](http://www.TomTom.jobs)

follow us on **LinkedIn**



**#ACHIEVEMORE**

**TOMTOM** 

In the previous Section we have discussed Castigliano's theorem that is based on the determination of the strain energy. The strain energy has been defined in Chapter 4. The individual strain energies for each basic loading are presented in Appendix A. Then using the principle of superposition we can express the total accumulated strain energy as the sum of individual energies accumulated for each load in the structure, i.e.

$$U = U_M + U_V + U_T + U_N \quad (5.16)$$

where  $U_M, U_V, U_T, U_N$  are strain energies caused by the bending moments, shear forces, torques and normal forces.

Let us consider the cantilever beam  $BC$  of length  $L$  subjected to the distributed load  $w$ , see Fig. 5.12. Our task is to calculate the deflection and the slope at its free end  $B$ . Castigliano's theorem can not be apply directly, because there are no concentrated forces, nor is there any applied couple at point  $B$ . To overcome this problem we apply a fictitious or dummy load in the required direction. Thus we can calculate the deflection as follows

$$\frac{\partial U}{\partial Q} = y_Q \quad (5.17)$$

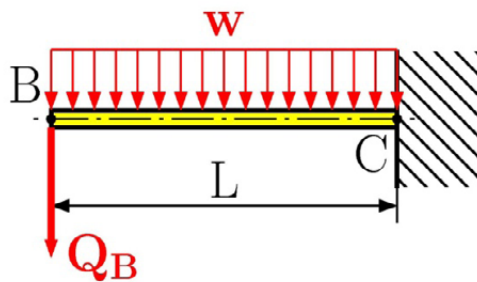


Fig. 5.13

Then making  $Q = 0$  in this equation, the deflection reaches a value corresponding to the given load. In our case we can apply a fictitious downwards force  $Q_B$  at point  $B$ , see Fig. 5.13. Then the bending moment distribution function is

$$M(x) = -Q_B - \frac{1}{2}wx^2 \quad (5.18)$$

using  $U \cong U_M$ , the effect of shear force contribution can be neglected and we have

$$y_B = \frac{\partial U}{\partial Q_B} = \int_0^L \frac{M(x)}{EI} \frac{\partial M(x)}{\partial Q_B} dx \quad (5.19)$$

The derivative of the bending moment with respect to the fictitious load is

$$\frac{\partial M(x)}{\partial Q_B} = -x \quad (5.20)$$

Substituting for  $M(x)$  and  $\frac{\partial M(x)}{\partial Q_B}$  from (5.18) and (5.20) into equation (5.19), and making  $Q_B = 0$  we obtain the deflection at point  $B$  for a given load

$$y_B = \frac{1}{EI} \int_0^L \left( -\frac{1}{2} wx^2 \right) (-x) dx = \frac{wL^4}{8EI} \quad (5.21)$$

The positive sign indicates the downwards direction since we assumed the fictitious downward load.

$$y_B = \frac{wL^4}{8EI} \downarrow \quad (5.22)$$

For determining the slope  $\theta_B$  we can apply a fictitious counterclockwise couple  $M_B$ , see Fig. 5.14. Then we have

$$M(x) = -M_B - \frac{1}{2} wx^2 \quad (5.23)$$

$$\theta_B = \frac{\partial U}{\partial M_B} = \int_0^L \frac{M(x)}{EI} \frac{\partial M(x)}{\partial M_B} dx \quad (5.24)$$

$$\frac{\partial M(x)}{\partial M_B} = -1 \quad (5.25)$$

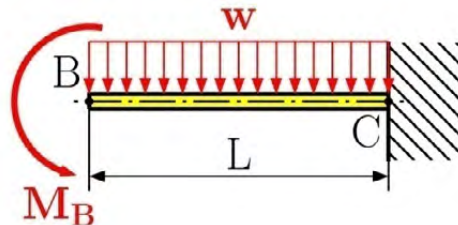


Fig. 5.15

Substituting for  $M(x)$  and  $\frac{\partial M(x)}{\partial M_B}$  from (5.23) and (5.25) into the equation (5.24), and making  $M_B = 0$  we obtain the slope at point  $B$  for a given load

$$\theta_B = \frac{1}{EI} \int_0^L \left( -\frac{1}{2} wx^2 \right) (-1) dx = \frac{wL^3}{6EI} \quad (5.26)$$

The positive sign indicates the counterclockwise direction since we assumed the fictitious counterclockwise load.

$$\theta_B = \frac{wL^3}{6EI} \curvearrowright \quad (5.27)$$

## 5.6 Statically Indeterminate Beams

Statically indeterminate problems can be solved in the usual way by removing the redundant supports and replacing them by unknown reactions. Then we can apply the step-by-step approach for determining internal force distribution functions. But these functions involve unknown reactions. To determine those reactions we can apply deformation conditions that correspond to the removed supports.

Let us consider the cantilever beam  $BC$  with a length  $L$  subjected to the distributed load  $w$ , see Fig. 5.15. The presented beam is statically indeterminate to the first degree. We replace the redundant support at  $B$  by the unknown reaction  $R_B$ . To get the same deformation response we need to impose the deformation condition

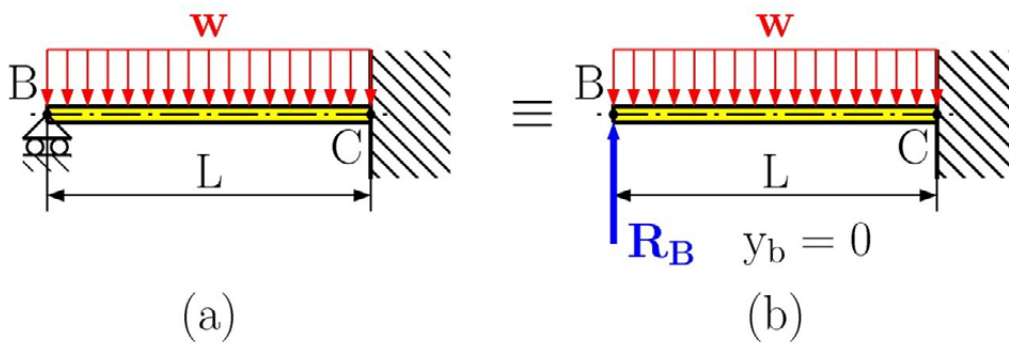


Fig. 5.15

$$y_B = \frac{\partial U}{\partial R_B} = \int_0^L \frac{M(x)}{EI} \frac{\partial M(x)}{\partial R_B} dx = 0 \quad (5.28)$$

The bending moment and its derivative can be expressed as

$$M(x) = R_B x - \frac{1}{2} w x^2 \quad (5.29)$$

$$\frac{\partial M(x)}{\partial R_B} = x \quad (5.30)$$

Substituting for  $M(x)$  and  $\frac{\partial M(x)}{\partial R_B} = x$  from (5.29) and (5.30) into equation (5.28) we get

$$0 = \frac{1}{EI} \int_0^L \left( R_B x - \frac{1}{2} w x^2 \right) (x) dx = \frac{R_B L^3}{3EI} - \frac{wL^4}{8EI} \quad (5.31)$$

Solving the above equation for the unknown reaction  $R_B$  we obtain

$$R_B = \frac{3}{8} wL \uparrow \quad (5.32)$$

The same problem can be solved by the integration method. We can use the same bending moment distribution function  $M(x) = R_B x - \frac{1}{2} w x^2$ , after substituting into equation (5.3) we have

$$\frac{d^2 y}{dx^2} = \frac{M(x)}{EI} = \frac{1}{EI} \left( R_B x - \frac{1}{2} w x^2 \right) \quad (5.33)$$

and by integrating we get

$$\frac{dy}{dx} = \theta(x) = \frac{1}{EI} \left( R_B \frac{x^2}{2} - \frac{1}{6} w x^3 \right) + C_1 \quad (5.34)$$

$$y(x) = \frac{1}{EI} \left( R_B \frac{x^3}{6} - \frac{1}{24} w x^4 \right) + C_1 x + C_2 \quad (5.35)$$

The equation (5.35) contains three unknowns: two integration constants  $C_1, C_2$  and the reaction  $R_B$ . Therefore we must impose three equations: two boundary conditions and one deformation condition as follows

$$\begin{aligned} x = L & & y_C = y(L) = 0 \\ x = L & & \theta_C = \theta(L) = 0 \\ x = 0 & & y_B = y(0) = 0 \end{aligned} \quad (5.36)$$

Solving this system of equations, we obtain the integration constants  $C_1 = -\frac{wL^3}{48EI}, C_2 = 0$  and the reaction  $R_B = \frac{3}{8} wL$ .

## 5.7 Examples, solved and unsolved problems

### Problem 5.1

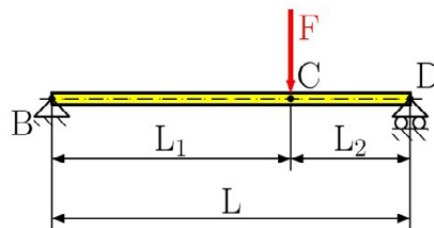


Fig. 5.16

For the loaded beam shown in Fig. 5.16, Determine (a) the equation of the elastic curve, deflection at point C, and slope at point B (b) Using the singularity function, express the deflection as a function of the distance  $x$  from support B, and determine the deflection at point C and slope at point B.

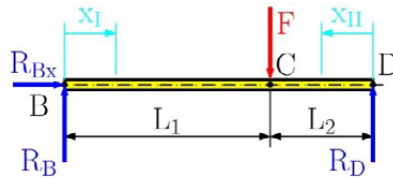
**Solution**

Fig. 5.17

Drawing the free-body diagram of the beam, see Fig. 5.17, we find reactions from the equilibrium equations

$$\sum F_{ix} = 0: R_{Bx} = 0$$

$$\sum M_{iA} = 0: R_D L - F L_1 = 0 \Rightarrow R_D = F \frac{L_1}{L}$$

$$\sum F_{iy} = 0: R_B + R_D - F = 0 \Rightarrow R_B = F \frac{L_2}{L}$$

# Brain power

By 2020, wind could provide one-tenth of our planet's electricity needs. Already today, SKF's innovative know-how is crucial to running a large proportion of the world's wind turbines.

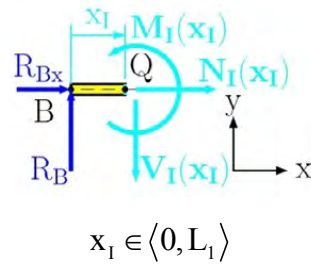
Up to 25 % of the generating costs relate to maintenance. These can be reduced dramatically thanks to our systems for on-line condition monitoring and automatic lubrication. We help make it more economical to create cleaner, cheaper energy out of thin air.

By sharing our experience, expertise, and creativity, industries can boost performance beyond expectations.

Therefore we need the best employees who can meet this challenge!

The Power of Knowledge Engineering

Plug into The Power of Knowledge Engineering.  
Visit us at [www.skf.com/knowledge](http://www.skf.com/knowledge)



$$x_I \in \langle 0, L_1 \rangle$$

Fig. 5.18

(a) the equation of the elastic curve, deflection at point C, and slope at point B

Drawing the free-body diagram of portion BQ of the beam (Fig. 5.18) and finding the moment about Q, we find that

$$\sum M_{iQ} = 0: M_I(x_I) - R_B x_I = 0 \Rightarrow M_I(x_I) = R_B x_I$$

$$M_I(x_I) = R_B x_I = F \frac{L_2}{L} x_I \quad (\text{a})$$

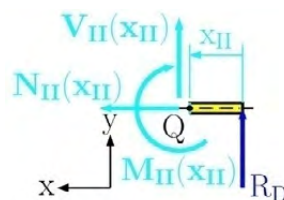
Substituting for M (Eqn. (a)) into Eq. (5.3) we write

$$\frac{d^2 y_I}{dx_I^2} = \frac{M}{EI} = \frac{1}{EI} (R_B x_I) = \frac{1}{EI} F \frac{L_2}{L} x_I.$$

Integrating twice in  $x_I$ , we have

$$\frac{dy_I}{dx_I} = \frac{F L_2}{EI L} \frac{x_I^2}{2} + C_1,$$

$$y_I(x_I) = \frac{F L_2}{EI L} \frac{x_I^3}{6} + C_1 x_I + C_2.$$



$$x_{II} \in \langle 0, L_2 \rangle$$

Fig. 5.19

Drawing the free-body diagram of portion QD of the beam (Fig. 5.19) and finding the moment about Q, we find that

$$\sum M_{iQ} = 0: -M_{II}(x_{II}) + R_D x_{II} = 0 \Rightarrow M_{II}(x_{II}) = R_D x_{II}$$

$$M_{II}(x_{II}) = R_D x_{II} = F \frac{L_1}{L} x_{II}. \quad (b)$$

Substituting for M (Eqn. (b)) into Eq. (5.3) we write

$$\frac{d^2 y_{II}}{dx_{II}^2} = \frac{M_{II}(x_{II})}{EI} = \frac{1}{EI} (R_D x_{II}) = \frac{1}{EI} F \frac{L_1}{L} x_{II}.$$

Integrate twice in  $x_{II}$ , we have

$$\frac{dy_{II}}{dx_{II}} = \frac{F L_1}{EI L} \frac{x_{II}^2}{2} + C_3,$$

$$y_{II}(x_{II}) = \frac{F L_1}{EI L} \frac{x_{II}^3}{6} + C_3 x_{II} + C_4.$$

The integration constant unknowns  $C_1$ ,  $C_2$ ,  $C_3$  and  $C_4$  are found through boundary conditions

- 1)  $x_I = 0 \Rightarrow y_I(x_I) = 0$ ,
- 2)  $x_{II} = 0 \Rightarrow y_{II}(x_{II}) = 0$ ,
- 3)  $x_I = L_1, x_{II} = L_2 \Rightarrow y_I(x_I) = y_{II}(x_{II})$ ,
- 4)  $x_I = L_1, x_{II} = L_2 \Rightarrow y'_I(x_I) = -y'_{II}(x_{II})$ .

Results from the boundary conditions are

$$y_I(x_I = 0) = 0 = \frac{F L_2}{EI L} \frac{0^3}{6} + C_1 \cdot 0 + C_2 \Rightarrow C_2 = 0$$

$$y_{II}(x_{II} = 0) = 0 = \frac{F L_1}{EI L} \frac{0^3}{6} + C_3 \cdot 0 + C_4 \Rightarrow C_4 = 0$$

$$C_1 = -\frac{F L_1 L_2 (L_1 + 2L_2)}{6EI} \quad C_3 = -\frac{F L_1 L_2 (2L_1 + L_2)}{6EI}$$

The equation of elastic curve in portion BC and CD is

$$y_I(x_I) = \frac{F L_2}{6EI} x_I^3 - \frac{F L_1 L_2 (L_1 + 2L_2)}{6EI} x_I \quad (c)$$

$$y_{II}(x_{II}) = \frac{F L_1}{6EI} x_{II}^3 - \frac{F L_1 L_2 (2L_1 + L_2)}{6EI} x_{II} \quad (d)$$

Deflection at point C is

$$y_I(x_I=L_1) = \frac{F L_2}{6EI} L_1^3 - \frac{F L_1 L_2 (L_1 + 2L_2)}{6EI} L_1 = -\frac{F L_1^2 L_2}{3EI}$$

and slope at point B is

$$\Theta(x_I=0) = \frac{dv}{dx} = \frac{F L_2}{EI} \frac{0^2}{2} + C_1 = C_1 = -\frac{F L_1 L_2 (L_1 + 2L_2)}{6EI}$$



**> Apply now**

REDEFINE YOUR FUTURE  
**AXA GLOBAL GRADUATE  
 PROGRAM 2015**

redefining / standards 

agence.cdg © Photomostop

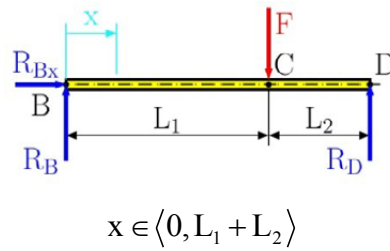


Fig. 5.20

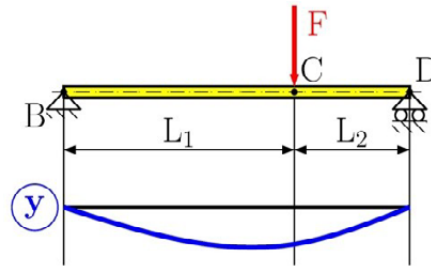


Fig. 5.21

(b) Using the singularity function, express the deflection as a function of the distance  $x$  from the support B and determine the deflection at point C and slope at point B.

From Fig. 4.11, we have

$$M(x) = R_B \langle x \rangle^1 - F \langle x - L_1 \rangle^1 \quad (e)$$

Using Eq. (5.3) and Eq. (e), we write

$$\frac{d^2 y}{dx^2} = \frac{M(x)}{EI} = \frac{1}{EI} \left[ R_B \langle x \rangle^1 - F \langle x - L_1 \rangle^1 \right]$$

and, integrating twice in  $x$ ,

$$EI \frac{dy}{dx} = \frac{R_B}{2} \langle x \rangle^2 - \frac{F}{2} \langle x - L_1 \rangle^2 + C_1 \quad (f)$$

$$EI y(x) = \frac{R_B}{6} \langle x \rangle^3 - \frac{F}{6} \langle x - L_1 \rangle^3 + C_1 x + C_2 \quad (g)$$

The boundary conditions are

$$1) \ x=0 \Rightarrow y(x) = 0,$$

$$2) \ x=L \Rightarrow y(x) = 0.$$

Using the first condition and noting that each bracket  $\langle \rangle$  contains a negative quantity, and thus equal to zero, we find

$$EI \cdot 0 = \frac{R_B}{6} \langle 0 \rangle^3 - \frac{F}{6} \langle 0 - L_1 \rangle^3 + C_1 \cdot 0 + C_2 \Rightarrow C_2 = 0$$

From the second condition we get

$$0 = \frac{R_B}{6} \langle L \rangle^3 - \frac{F}{6} \langle L - L_1 \rangle^3 + C_1 L \Rightarrow C_1 = -\frac{FL_1 L_2}{6L} (L_1 + 2L_2)$$

Substituting  $C_1$  and  $C_2$  into Eq. (g), we have

$$y(x) = \frac{1}{EI} \left[ \frac{R_B}{6} \langle x \rangle^3 - \frac{F}{6} \langle x - L_1 \rangle^3 - \frac{FL_1 L_2}{6L} (L_1 + 2L_2) x \right]$$

*Deflection at point D.* Substituting  $x = L_1$  into the deflection curve equation, we find

$$y(x=L_1) = \frac{1}{EI} \left[ \frac{R_B}{6} \langle L_1 \rangle^3 - \frac{F}{6} \langle L_1 - L_1 \rangle^3 - \frac{FL_1^2 L_2}{6L} (L_1 + 2L_2) \right]$$

$$y(x=L_1) = -\frac{FL_1^2 L_2^2}{3 EI L}$$

The slope at B is

$$\Theta(x=0) = \frac{dv}{dx} = \frac{1}{EI} \left[ \frac{R_B}{2} \langle 0 \rangle^2 - \frac{F}{2} \langle 0 - L_1 \rangle^2 - \frac{FL_1 L_2}{6L} (L_1 + 2L_2) \right]$$

$$\Theta(x=0) = -\frac{F L_1 L_2 (L_1 + 2L_2)}{6EI L}$$

## Problem 5.2

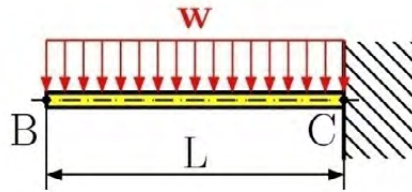


Fig. 5.22

For the uniformly loaded beam in Fig. 5.22, Determine (a) the equation of the elastic curve and the deflection and slope at point B (b) Using the singularity function, express the deflection as a function of distance  $x$  from the free end at B and determine the deflection and slope at point B.

## Solution

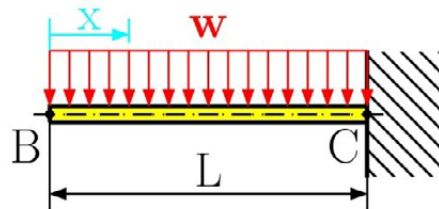


Fig. 5.23

## LIGS University

based in Hawaii, USA

is currently enrolling in the  
Interactive Online **BBA, MBA, MSc,**  
**DBA and PhD** programs:

- ▶ enroll **by October 31st, 2014** and
- ▶ **save up to 11%** on the tuition!
- ▶ pay in 10 installments / 2 years
- ▶ Interactive **Online** education
- ▶ visit [www.ligsuniversity.com](http://www.ligsuniversity.com) to find out more!

Note: LIGS University is not accredited by any nationally recognized accrediting agency listed by the US Secretary of Education. More info [here](#).



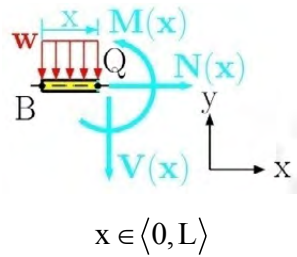


Fig. 5.24

(a) the equation of the elastic curve and the deflection and slope at point B

Drawing the free-body diagram of portion BQ (Fig. 5.24) we take the moment about Q and find that

$$\sum M_{iQ} = 0: M(x) + \frac{wx^2}{2} = 0 \Rightarrow M(x) = -\frac{wx^2}{2} \quad (\text{a})$$

Using Eq. (5.3) and Eq. (e), we write

$$\frac{d^2y}{dx^2} = \frac{M}{EI} = \frac{1}{EI} \left( -\frac{wx^2}{2} \right) = -\frac{wx^2}{2EI}$$

and integrating twice in x,

$$\frac{dy}{dx} = -\frac{wx^3}{6EI} + C_1 \quad (\text{b})$$

The boundary conditions are

$$1) \quad x=L \Rightarrow y(x) = 0,$$

$$2) \quad x=L \Rightarrow y'(x) = 0.$$

and from the second boundary condition, we have

$$\left. \frac{dy}{dx} \right|_{x=L} = 0 = -\frac{wL^3}{6EI} + C_1 \Rightarrow C_1 = \frac{wL^3}{6EI}$$

using the first boundary condition, we get

$$y(x=L) = 0 = -\frac{wL^4}{24EI} + \frac{wL^4}{6EI} + C_2 \Rightarrow C_2 = -\frac{1}{8} \frac{wL^4}{EI}$$

Substituting  $C_1$  and  $C_2$  into Eq. (b), we have

$$y(x) = -\frac{wx^4}{24EI} + \frac{wL^3}{6EI}x - \frac{1}{8} \frac{wL^4}{EI} \quad (c)$$

Substituting  $x = 0$  into Eq. (c), we find the deflection at point B

$$y_B = y(x=0) = -\frac{1}{8} \frac{wL^4}{EI}$$

and slope at point B

$$\Theta_B = \Theta(x=0) = \frac{dv}{dx} = -\frac{w0^3}{6EI} + \frac{wL^3}{6EI} = \frac{wL^3}{6EI}$$

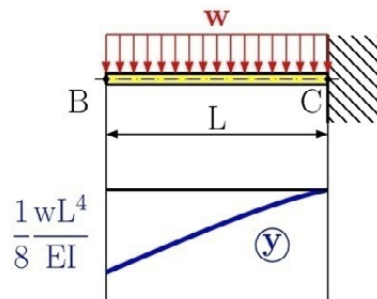


Fig. 5.25

(b) Using the singularity function, express the deflection as a function of the distance  $x$  from the free end at B and determine the deflection slope at point B.

The equation defining the bending moment of beam using Fig. 4.11, we have

$$M(x) = -\frac{w}{2} \langle x \rangle^2 \quad (d)$$

Using Eq. (5.3) and Eq. (d), we write

$$\frac{d^2y}{dx^2} = \frac{M(x)}{EI} = \frac{1}{EI} \left[ -\frac{w}{2} \langle x \rangle^2 \right]$$

and multiplying both members of this equation by the constant EI, we have

$$EI \frac{d^2y}{dx^2} = -\frac{w}{2} \langle x \rangle^2.$$

Integrating twice in  $w$ , we get

$$EI \frac{dy}{dx} = -\frac{w}{6} \langle x \rangle^3 + C_1$$

$$EI y(x) = -\frac{w}{24} \langle x \rangle^4 + C_1 x + C_2 \quad (e)$$

The boundary conditions from Fig. 5.23 are

$$1) \quad x=L \Rightarrow y(x) = 0,$$

$$2) \quad x=L \Rightarrow y'(x) = 0.$$

From which, we have

$$EI \frac{dy}{dx} = 0 = -\frac{w}{6} \langle L \rangle^3 + C_1 \Rightarrow C_1 = \frac{wL^3}{6}$$

and

## TURN TO THE EXPERTS FOR SUBSCRIPTION CONSULTANCY

Subscribe is one of the leading companies in Europe when it comes to innovation and business development within subscription businesses.

We innovate new subscription business models or improve existing ones. We do business reviews of existing subscription businesses and we develop acquisition and retention strategies.

Learn more at [linkedin.com/company/subscribe](https://www.linkedin.com/company/subscribe) or contact  
Managing Director Morten Suhr Hansen at [mha@subscribe.dk](mailto:mha@subscribe.dk)

**SUBSCR**✓**IBE** - to the future

$$EI y(x=L) = 0 = -\frac{w}{24} \langle L \rangle^4 + \frac{wL^3}{6} L + C_2$$

$$C_2 = -\frac{1}{8} wL^4$$

Substituting  $C_1$  and  $C_2$  into Eq. (e), we have

$$y(x) = \frac{1}{EI} \left[ -\frac{w}{24} \langle x \rangle^4 + \frac{wL^3}{6} x - \frac{1}{8} wL^4 \right]$$

The deflection at point B is

$$y_B = y(x=0) = \frac{1}{EI} \left[ -\frac{w}{24} \langle 0 \rangle^4 + \frac{wL^3}{6} 0 - \frac{1}{8} wL^4 \right] = -\frac{1}{8} \frac{wL^4}{EI}$$

The slope at point B is

$$\Theta_B = \Theta(x=0) = \frac{dv}{dx} = \frac{1}{EI} \left[ -\frac{w}{6} \langle 0 \rangle^3 + \frac{wL^3}{6} \right] = \frac{wL^3}{6EI}$$

### Problem 5.3

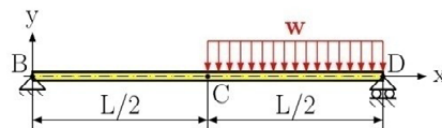


Fig. 5.26

For the beam and loading shown in Fig. 5.26 Determine (a) the equation of the elastic curve, deflection at C, and slope at B and C (b) Using the singularity function, express the deflection as a function of the distance  $x$  from the support at B and determine the deflection at C and slope at B and C.

### Solution

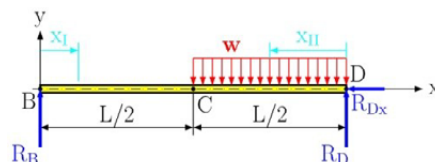


Fig. 5.27

From the free-body diagram in Fig. 5.27 we have the reactions

$$\sum F_{ix} = 0: R_{Dx} = 0$$

$$\sum M_{iB} = 0: R_D L - w \frac{L}{2} \left( \frac{L}{2} + \frac{L}{4} \right) = 0 \Rightarrow R_D = \frac{3}{8} wL$$

$$\sum F_{iy} = 0: R_B + R_D - \frac{wL}{2} = 0 \Rightarrow R_B = \frac{1}{8} wL$$

Drawing the free-body diagram of portion BQ of the beam (Fig. 5.28) and finding the moment about Q, we see that

$$\sum M_{iQ} = 0: M_I(x_I) - R_B x_I = 0 \Rightarrow M_I(x_I) = R_B x_I$$

$$M_I(x_I) = \frac{1}{8} wL x_I \quad (a)$$

inserting this result into the differential equation of an elastic curve, we get

$$\frac{d^2 y_I}{dx_I^2} = \frac{M}{EI} = \frac{1}{EI} \frac{1}{8} wL x_I$$

Integrating twice in  $x$ , we have

$$\frac{dy_I}{dx_I} = \frac{wL}{8EI} \frac{x_I^2}{2} + C_1$$

$$y_I(x_I) = \frac{wL}{48EI} x_I^3 + C_1 x_I + C_2 \quad (b)$$

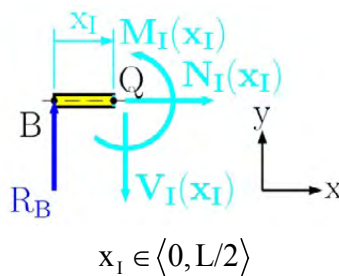


Fig. 5.28

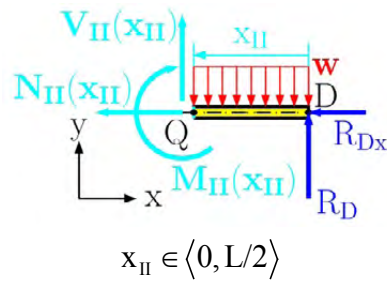


Fig. 5.29

In the same way, we find the elastic curve in portion QD, from Fig. 5.29, we have

$$\sum M_{iQ} = 0: -M_{II}(x_{II}) + R_D x_{II} - \frac{w x_{II}^2}{2} = 0$$

$$M_{II}(x_{II}) = R_D x_{II} - \frac{w x_{II}^2}{2} = \frac{3}{8} w L x_{II} - \frac{w x_{II}^2}{2} \quad (c)$$

and

$$\frac{d^2 y_{II}}{dx_{II}^2} = \frac{M_{II}(x_{II})}{EI} = \frac{1}{EI} \left[ \frac{3}{8} w L x_{II} - \frac{w x_{II}^2}{2} \right]$$

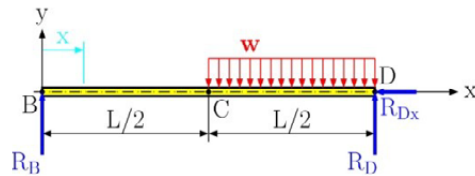
“I studied English for 16 years but...  
...I finally learned to speak it in just six lessons”  
Jane, Chinese architect

ENGLISH OUT THERE

Click to hear me talking before and after my unique course download

$$\frac{dy_{II}}{dx_{II}} = \frac{1}{EI} \left[ \frac{3}{8} wL \frac{x_{II}^2}{2} - \frac{wx_{II}^3}{6} \right] + C_3$$

$$y_{II}(x_{II}) = \frac{3wL}{48EI} x_{II}^3 - \frac{wx_{II}^4}{24EI} + C_3 x_{II} + C_4 \quad (d)$$



$$x \in \langle 0, L \rangle$$

Fig. 5.30

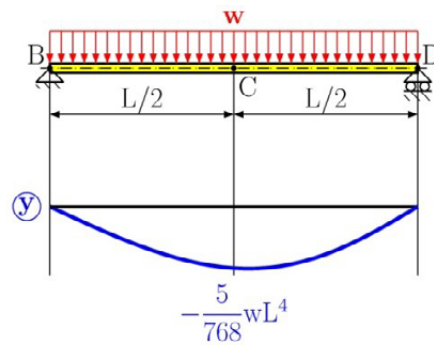


Fig. 5.31

The boundary conditions, from Fig. 5.26, are

- 1)  $x_I=0 \Rightarrow y_I(x_I)=0$ ,
- 2)  $x_{II}=0 \Rightarrow y_{II}(x_{II})=0$ ,
- 3)  $x_I=L/2, x_{II}=L/2 \Rightarrow y_I(x_I)=y_{II}(x_{II})$
- 4)  $x_I=L/2, x_{II}=L/2 \Rightarrow y'_I(x_I)=-y'_{II}(x_{II})$

After using all the conditions, we solve for the integration constants

$$C_1 = -\frac{7 wL^3}{384 EI}, \quad C_2 = 0, \quad C_3 = -\frac{3 wL^3}{128 EI}, \quad C_4 = 0.$$

and the equations of the elastic curve are

$$y_I(x_I) = \frac{wL}{48EI} x_I^3 - \frac{7wL^3}{384EI} x_I \quad (e)$$

$$y_{II}(x_{II}) = \frac{3wL}{48EI} x_{II}^3 - \frac{wx_{II}^4}{24EI} - \frac{3wL^3}{128EI} x_{II} \quad (f)$$

The deflection at point C is

$$y_C = y_I \left( x_I = \frac{L}{2} \right) = \frac{wL}{48EI} \left( \frac{L}{2} \right)^3 - \frac{7wL^3}{384EI} \left( \frac{L}{2} \right) = -\frac{5wL^4}{768EI}$$

and the slope at point C is

$$\Theta_C = \Theta \left( x_I = \frac{L}{2} \right) = \frac{wL}{16EI} \left( \frac{L}{2} \right)^2 - \frac{7wL^3}{384EI} = -\frac{1wL^3}{384EI}$$

The slope at point B is

$$\Theta_B = \Theta(x_I = 0) = \frac{wL}{16EI} (0)^2 - \frac{7wL^3}{384EI} = -\frac{7wL^3}{384EI}$$

(b) Using the singularity function, express the deflection as a function of the distance  $x$  from the support at B and determine the deflection at C and slope at B and C.

Using Fig. 4.11, we have

$$M(x) = R_B \langle x \rangle^1 - \frac{w}{2} \left\langle x - \frac{L}{2} \right\rangle^2 = \frac{wL}{8} \langle x \rangle^1 - \frac{w}{2} \left\langle x - \frac{L}{2} \right\rangle^2$$

Substituting  $M(x)$  into Eq. (5.3), we have

$$\frac{d^2y}{dx^2} = \frac{M(x)}{EI} = \frac{1}{EI} \left[ \frac{wL}{8} \langle x \rangle^1 - \frac{w}{2} \left\langle x - \frac{L}{2} \right\rangle^2 \right]$$

now multiplying by  $EI$ , we get

$$EI \frac{d^2y}{dx^2} = \frac{wL}{8} \langle x \rangle^1 - \frac{w}{2} \left\langle x - \frac{L}{2} \right\rangle^2$$

Integrating twice with respect to  $x$ , we have

$$EI \frac{dy}{dx} = \frac{wL}{16} \langle x \rangle^2 - \frac{w}{16} \left\langle x - \frac{L}{2} \right\rangle^3 + C_1$$

$$EI y(x) = \frac{wL}{48} \langle x \rangle^3 - \frac{w}{64} \left\langle x - \frac{L}{2} \right\rangle^4 + C_1 x + C_2 \quad (g)$$

The boundary conditions are

- 1)  $x = 0 \Rightarrow y(x) = 0$ ,
- 2)  $x = L \Rightarrow y(x) = 0$ ,

from which we have




$$C_1 = -\frac{7wL^3}{384}, \quad C_2 = 0.$$

The equation of the elastic curve using a singularity function is

**wethrive.net**

**How to retain your top staff**  
FIND OUT NOW FOR FREE

**DO YOU WANT TO KNOW:**

-  What your staff really want?
-  The top issues troubling them?
-  How to make staff assessments work for you & them, painlessly?

**Get your free trial**  
Because happy staff get more done

$$y(x) = \frac{1}{EI} \left[ \frac{wL}{48} \langle x \rangle^3 - \frac{w}{64} \left\langle x - \frac{L}{2} \right\rangle^4 - \frac{7wL^3}{384} x \right] \quad (h)$$

The deflection at point C is

$$y\left(x = \frac{L}{2}\right) = \frac{1}{EI} \left[ \frac{wL}{48} \left\langle \frac{L}{2} \right\rangle^3 - \frac{w}{64} \left\langle \frac{L}{2} - \frac{L}{2} \right\rangle^4 - \frac{7wL^3}{384} \frac{L}{2} \right]$$

$$y_C = v\left(x = \frac{L}{2}\right) = -\frac{5wL^4}{768 EI}$$

while the slope at point C is

$$\Theta\left(x = \frac{L}{2}\right) = \frac{dv}{dx} = \frac{1}{EI} \left[ \frac{wL}{16} \left\langle \frac{L}{2} \right\rangle^2 - \frac{w}{16} \left\langle \frac{L}{2} - \frac{L}{2} \right\rangle^3 - \frac{7wL^3}{384} \right]$$

$$\Theta_C = \Theta\left(x = \frac{L}{2}\right) = -\frac{wL^3}{384 EI}$$

The slope at point B is

$$\Theta\left(x = \frac{L}{2}\right) = \frac{1}{EI} \left[ \frac{wL}{16} \langle 0 \rangle^2 - \frac{w}{16} \left\langle 0 - \frac{L}{2} \right\rangle^3 - \frac{7wL^3}{384} \right] \Theta_B = \Theta\left(x = \frac{L}{2}\right) = -\frac{7wL^3}{384 EI}$$

#### Problem 5.4

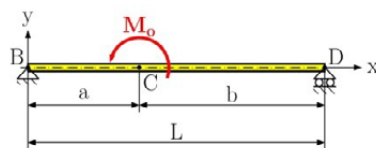
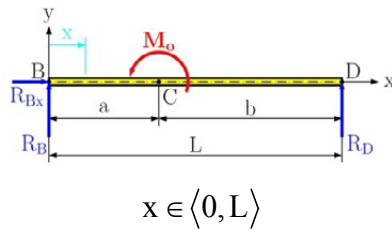


Fig. 5.32

For a beam subjected to a moment shown in Fig. 5.32 determine (a) using a singularity function, find the deflection as a function of the distance  $x$  from the support at B, (b) the deflection at C and slope at B.

**Solution****Fig. 5.33**

From the free-body diagram in Fig. 5.33 we have the reactions

$$\sum F_{ix} = 0: R_{Bx} = 0$$

$$\sum M_{iB} = 0: R_D L + M_o = 0 \Rightarrow R_D = -\frac{M_o}{L}$$

$$\sum F_{iy} = 0: R_B + R_D = 0 \Rightarrow R_B = -R_D = \frac{M_o}{L}$$

Using Fig. 4.11 we obtain the bending moment at  $x$  (see Fig. 5.33)

$$M(x) = R_B \langle x \rangle^1 - M_o \langle x - a \rangle^0 = \frac{M_o}{L} \langle x \rangle^1 - M_o \langle x - a \rangle^0$$

We insert the last expression into the equation of the elastic curve Eq. (5.3) and get

$$\frac{d^2 y}{dx^2} = \frac{M(x)}{EI} = \frac{1}{EI} \left[ \frac{M_o}{L} \langle x \rangle^1 - M_o \langle x - a \rangle^0 \right]$$

$$EI \frac{d^2 y}{dx^2} = \frac{M_o}{L} \langle x \rangle^1 - M_o \langle x - a \rangle^0$$

After double Integrating the last expression, we have

$$EI \frac{dy}{dx} = \frac{M_o}{2L} \langle x \rangle^2 - M_o \langle x - a \rangle^1 + C_1$$

$$EI y(x) = -\frac{M_o}{6L} \langle x \rangle^3 - \frac{M_o}{2} \langle x - a \rangle^2 + C_1 x + C_2 \quad (\text{a})$$

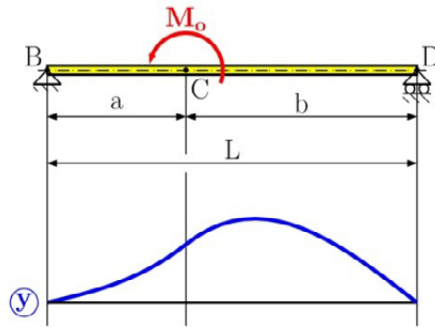


Fig. 5.34

Constants  $C_1$  and  $C_2$  can be determined from the boundary condition shown in Fig. 5.34. Setting  $x = 0$ ,  $y = 0$  in Eq. (a) and noting that all brackets contain negative quantities, therefore equal to zero, we conclude that

$$C_2 = 0.$$

Now setting  $x = L$ ,  $y = 0$ , and  $C_2 = 0$  in Eq. (a), we write

$$EI y(x = L) = 0 = -\frac{M_o}{6L} \langle L \rangle^3 - \frac{M_o}{2} \langle L - a \rangle^2 + C_1 L.$$

**gaiteye**  
Challenge the way we run

**EXPERIENCE THE POWER OF FULL ENGAGEMENT...**

**RUN FASTER.  
RUN LONGER..  
RUN EASIER...**

**READ MORE & PRE-ORDER TODAY  
WWW.GAITEYE.COM**

Since all the quantities between the brackets are positive, the brackets can be replaced by ordinary parentheses. Solving for  $C_1$ , we find

$$C_1 = \frac{M_o}{6L}(3b^2 - L^2)$$

Substituting  $C_1$  and  $C_2$  into Eq. (a), we have

$$y(x) = \frac{1}{EI} \left[ -\frac{M_o}{6L} \langle x \rangle^3 - \frac{M_o}{2} \langle x - a \rangle^2 + \frac{M_o}{6L} (3b^2 - L^2) x \right]$$

We find the deflection at point C

$$y(x = a) = \frac{1}{EI} \left[ -\frac{M_o}{6L} \langle a \rangle^3 + \frac{M_o}{6L} (3b^2 - L^2) a \right]$$

$$y_C = y(x = a) = \frac{M_o}{3EI L} ab(b - a).$$

The slope at point B we find

$$\Theta(0) = \frac{dv}{dx} = \frac{1}{EI} \left[ -\frac{M_o}{2L} \langle 0 \rangle^2 - M_o \langle 0 - a \rangle^1 + \frac{M_o}{6L} (3b^2 - L^2) \right]$$

$$\Theta_B = \Theta(0) = \frac{M_o}{6EI L} (3b^2 - L^2)$$

### Problem 5.5

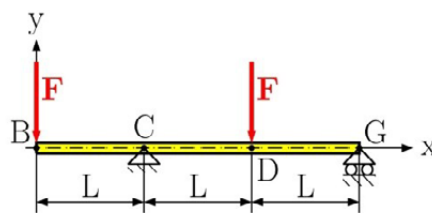
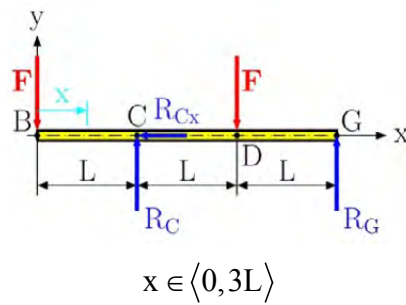


Fig. 5.35

Using the singularity functions for the beam shown in Fig. 5.35 determine (a) the deflection as a function of the distance  $x$  from the support at B, (b) the deflection at B, D and slope at G.

**Solution****Fig. 5.36**

From the free-body diagram in Fig. 5.36 we have the reactions

$$\sum F_{ix} = 0: R_{Cx} = 0$$

$$\sum M_{iG} = 0: F3L - R_C 2L + FL = 0 \Rightarrow R_C = 2F$$

$$\sum F_{iy} = 0: R_C + R_G - 2F = 0 \Rightarrow R_G = 0$$

Using Fig. 4.11 we obtain the bending moment at  $x$  (see Fig. 5.36)

$$M(x) = -F\langle x \rangle^1 + R_C \langle x - L \rangle^1 - F\langle x - 2L \rangle^1$$

$$M(x) = -F\langle x \rangle^1 + 2F\langle x - L \rangle^1 - F\langle x - 2L \rangle^1 \quad (\text{a})$$

Substituting Eq. (a) into the equation of the elastic curve Eq. 5.3 we get

$$\frac{d^2 y}{dx^2} = \frac{M(x)}{EI} = \frac{1}{EI} \left[ -F\langle x \rangle^1 + 2F\langle x - L \rangle^1 - F\langle x - 2L \rangle^1 \right]$$

$$EI \frac{d^2 y}{dx^2} = -F\langle x \rangle^1 + 2F\langle x - L \rangle^1 - F\langle x - 2L \rangle^1$$

After double integrating with respect to  $x$ , we have

$$EI \frac{dy}{dx} = -\frac{F}{2}\langle x \rangle^2 + F\langle x - L \rangle^2 - \frac{F}{2}\langle x - 2L \rangle^2 + C_1$$

$$EI y(x) = -\frac{F}{6}\langle x \rangle^3 + \frac{F}{3}\langle x - L \rangle^3 - \frac{F}{6}\langle x - 2L \rangle^3 + C_1 x + C_2 \quad (\text{b})$$

The boundary conditions are

- 1)  $x = L \Rightarrow y(x) = 0$ ,
- 2)  $x = 3L \Rightarrow y(x) = 0$ ,

from which we have

$$C_1 = \frac{11}{12}FL^2 \quad C_2 = -\frac{3}{4}FL^3.$$

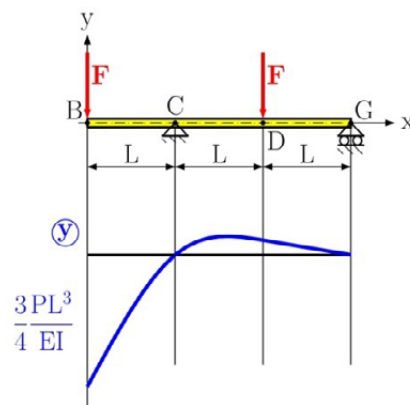


Fig. 5.37

This e-book  
is made with  
**SetaPDF**



PDF components for PHP developers

[www.setasign.com](http://www.setasign.com)

The equation of the deflection curve is

$$y(x) = \frac{1}{EI} \left[ -\frac{F}{6} \langle x \rangle^3 + \frac{F}{3} \langle x-L \rangle^3 - \frac{F}{6} \langle x-2L \rangle^3 \right] + \frac{1}{EI} \left[ \frac{11}{12} FL^2 x - \frac{3}{4} FL^3 \right] \quad (c)$$

and is graphically shown in Fig. 5.37.

The deflection at point B is

$$y_B = y(x=0) = \frac{1}{EI} C_2 = -\frac{3 FL^3}{4 EI}.$$

while the deflection at point D is

$$y_D = y(x=2L) = -\frac{5 FL^3}{6 EI}.$$

and the slope at point G is

$$\Theta(x) = \frac{dv}{dx} = \frac{1}{EI} \left[ -\frac{M_o}{2L} \langle x \rangle^2 - M_o \langle x-a \rangle^1 + \frac{M_o}{6L} (3b^2 - L^2) \right]$$

$$\Theta_G = \Theta(x=3L) = -\frac{47 PL^2}{4 EI}.$$

### Problem 5.6

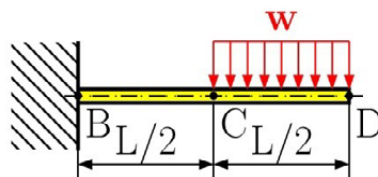
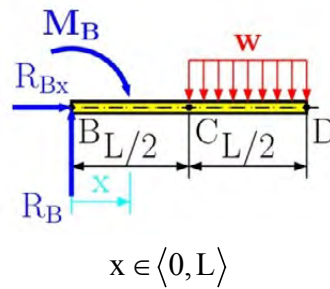


Fig. 5.38

Using the singularity functions for the beam shown in Fig. 5.38 determine (a) the deflection as a function of the distance  $x$  from the support at B, (b) the deflection at B and D.

**Solution****Fig. 5.39**

We begin by solving for the reaction at point B, because  $x$  starts from point B. From the free-body diagram in Fig. 5.39 we have the reactions

$$\sum F_{ix} = 0: R_{Bx} = 0$$

$$\sum F_{iy} = 0: R_B - \frac{wL}{2} = 0 \Rightarrow R_B = \frac{wL}{2}$$

$$\sum M_{iB} = 0: M_B + w \frac{L}{2} \left( \frac{L}{2} + \frac{L}{4} \right) = 0 \Rightarrow M_B = -\frac{3}{8} wL^2$$

The bending moment using the singularity function is

$$M(x) = R_B \langle x \rangle^1 + M_B \langle x \rangle^0 - \frac{w}{2} \left\langle x - \frac{L}{2} \right\rangle^2$$

$$M(x) = \frac{wL}{2} \langle x \rangle^1 - \frac{3}{8} wL^2 \langle x \rangle^0 - \frac{w}{2} \left\langle x - \frac{L}{2} \right\rangle^2.$$

Substituting  $M(x)$  into the elastic curve equation we get

$$\frac{d^2y}{dx^2} = \frac{M(x)}{EI} = \frac{1}{EI} \left[ \frac{wL}{2} \langle x \rangle^1 - \frac{3}{8} wL^2 \langle x \rangle^0 - \frac{w}{2} \left\langle x - \frac{L}{2} \right\rangle^2 \right]$$

$$EI \frac{d^2y}{dx^2} = \frac{wL}{2} \langle x \rangle^1 - \frac{3}{8} wL^2 \langle x \rangle^0 - \frac{w}{2} \left\langle x - \frac{L}{2} \right\rangle^2.$$

Double integrating the last equation with respect to  $x$ , we get

$$EI \frac{dy}{dx} = \frac{wL}{4} \langle x \rangle^2 - \frac{3}{8} wL^2 \langle x \rangle^1 - \frac{w}{6} \left\langle x - \frac{L}{2} \right\rangle^3 + C_1$$

$$EI y(x) = \frac{wL}{12} \langle x \rangle^3 - \frac{3}{16} wL^2 \langle x \rangle^2 - \frac{w}{24} \left\langle x - \frac{L}{2} \right\rangle^4 + C_1 x + C_2$$

(a)

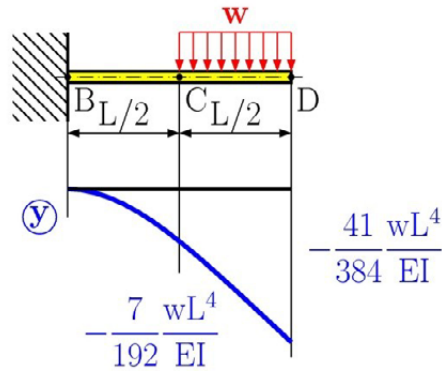


Fig. 5.40



Discover the truth at [www.deloitte.ca/careers](http://www.deloitte.ca/careers)

**Deloitte.**

© Deloitte & Touche LLP and affiliated entities.



The boundary conditions from Fig. 5.40 are

$$1) \quad x = 0 \Rightarrow y(x) = 0,$$

$$2) \quad x = 0 \Rightarrow \frac{d y(x)}{d x} = 0,$$

from which we get

$$C_1 = 0, \quad C_2 = 0.$$

After substituting  $C_1$  and  $C_2$  into Eq. (a) we get the deflection at  $x$

$$y(x) = \frac{1}{EI} \left[ \frac{wL}{12} \langle x \rangle^3 - \frac{3}{16} wL^2 \langle x \rangle^2 - \frac{w}{24} \left\langle x - \frac{L}{2} \right\rangle^4 \right]$$

Graphically the deflection curve is shown in Fig. 5.40.

Deflection at point C is

$$y_C = y(x = L/2) = \frac{1}{EI} \left[ \frac{wL}{12} \left\langle \frac{L}{2} \right\rangle^3 - \frac{3}{16} wL^2 \left\langle \frac{L}{2} \right\rangle^2 \right]$$

$$y_C = y(x = L/2) = -\frac{7}{192} \frac{wL^4}{EI}.$$

Deflection at point D is

$$y(x = L) = \frac{1}{EI} \left[ \frac{wL}{12} L^3 - \frac{3}{16} wL^4 - \frac{w}{24} \left\langle \frac{L}{2} \right\rangle^4 \right]$$

$$y_D = y(x = L) = -\frac{41}{384} \frac{wL^4}{EI}.$$

### Problem 5.7

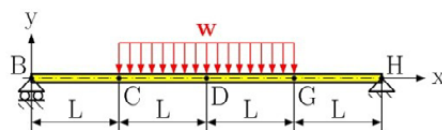


Fig. 5.41

Using the singularity functions for the beam shown in Fig. 5.41 determine (a) the deflection as a function of the distance  $x$  from the support at B, (b) the deflection at C.

### Solution

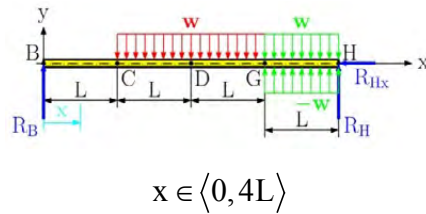


Fig. 5.42

From the free-body diagram in Fig. 5.42 we find the reactions

$$\sum F_{ix} = 0: R_{Hx} = 0$$

$$\sum M_{iB} = 0: R_H 4L + w 2L (2L) = 0 \Rightarrow R_H = wL$$

$$\sum F_{iy} = 0: R_B + R_H - w 2L = 0 \Rightarrow R_B = wL$$

The bending moment, see Fig. 4.11, are

$$M(x) = R_B \langle x \rangle^1 - \frac{w}{2} \langle x - L \rangle^2 + \frac{w}{2} \langle x - 3L \rangle^2$$

$$M(x) = wL \langle x \rangle^1 - \frac{w}{2} \langle x - L \rangle^2 + \frac{w}{2} \langle x - 3L \rangle^2 \quad (a)$$

Using Eq. (5.3), we write

$$EI \frac{d^2 y}{dx^2} = wL \langle x \rangle^1 - \frac{w}{2} \langle x - L \rangle^2 + \frac{w}{2} \langle x - 3L \rangle^2$$

and then double integrate with respect to  $x$ ,

$$EI \frac{dy}{dx} = \frac{wL}{2} \langle x \rangle^2 - \frac{w}{6} \langle x - L \rangle^3 + \frac{w}{6} \langle x - 3L \rangle^3 + C_1$$

$$EI y(x) = \frac{wL}{6} \langle x \rangle^3 - \frac{w}{24} \langle x-L \rangle^4 + \frac{w}{24} \langle x-3L \rangle^4 + C_1 x + C_2$$

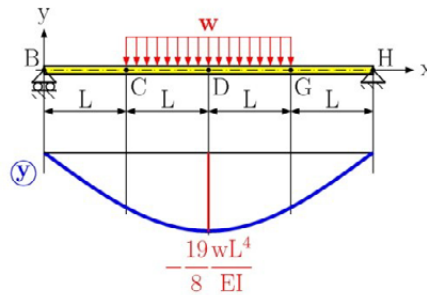


Fig. 5.43

Using the following boundary conditions (see Fig. 5.43)

- 1)  $x=0 \Rightarrow y(x) = 0$ ,
- 2)  $x=4L \Rightarrow y(x) = 0$ .

then

$$C_1 = -\frac{11}{6} wL^3, \quad C_2 = 0.$$

© 2013 Accenture. All rights reserved.

be > your degree

Bring your talent and passion to a global organization at the forefront of business, technology and innovation. Discover how great you can be.

Visit [accenture.com/bookboon](http://accenture.com/bookboon)

Be greater than.  
consulting | technology | outsourcing

accenture  
High performance. Delivered.

The equation of the elastic curve using singularity function is

$$y(x) = \frac{1}{EI} \left[ \frac{wL}{6} \langle x \rangle^3 - \frac{w}{24} \langle x - L \rangle^4 + \frac{w}{24} \langle x - 3L \rangle^4 - \frac{11}{6} wL^3 x \right]$$

Deflection at point C is

$$y_C = y(x = 2L) = -\frac{19 wL^4}{8 EI}.$$

### Problem 5.8

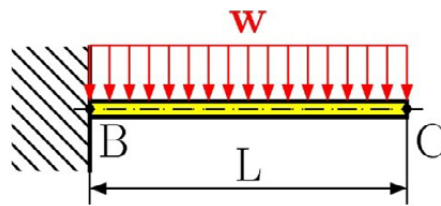
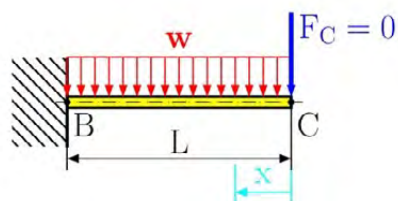


Fig. 5.44

Apply Castigliano's theorem for determining the deflection at point C of the beam presented in Fig. 5.44.

### Solution



$$x \in \langle 0, L \rangle$$

Fig. 5.45

To solve using Castigliano's theorem's we need to apply an external force at the point that we wish to find the deflection. Therefore, at point C, we assume a zero value force  $F_C$ .

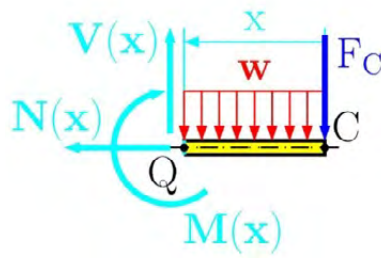


Fig. 5.46

Drawing the free-body diagram of portion CQ (Fig. 5.46) and taking the moment about Q, we find that

$$\sum M_{iQ} = 0: -M(x) - w x \frac{x}{2} - F_C x = 0$$

$$M(x) = -w x \frac{x}{2} - F_C x \quad (a)$$

Definition of deflection by Castigliano is

$$y_C = \frac{\partial U}{\partial F_C} \quad (b)$$

where  $U$  is the strain energy defined in Appendix, Eq. (A.31), which is

$$U = \int_0^L \frac{M^2}{2EI^2} \left( \int y^2 dA \right) dx = \int_0^L \frac{M^2}{2EI} dx$$

Substituting Eq. (A.31) into (b), we have

$$y_C = \frac{\partial U}{\partial F_C} = \frac{1}{EI} \int_0^L M(x) \frac{\partial M(x)}{\partial F_C} dx \quad (c)$$

Substituting Eq. (a) into Eq. (c), we get

$$y_C = \frac{\partial U}{\partial F_C} = \frac{1}{EI} \int_0^L \left[ -w x \frac{x}{2} - F_C x \right] \frac{\partial}{\partial F_C} \left[ -w x \frac{x}{2} - F_C x \right] dx$$

$$y_C = \frac{\partial U}{\partial F_C} = \frac{1}{EI} \int_0^L \left[ -w x \frac{x}{2} - F_C x \right] (-x) dx$$

After integration we have the deflection at point C

$$y_C = \frac{1}{EI} \int_0^L \left[ \frac{w}{2} x^3 \right] dx = \frac{w}{2EI} \left[ \frac{x^4}{4} \right]_0^L = \frac{wL^4}{8EI} \quad (d)$$

### Problem 5.9

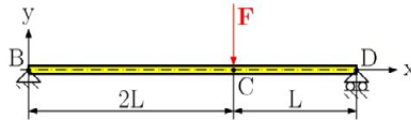


Fig. 5.47

For the beam and load shown in Fig. 5.47, use the Castigliano's theorem to determine the deflection at C.

### Solution

From the free-body diagram in Fig. 5.47 we find the following reactions

$$\sum F_{ix} = 0: R_{Bx} = 0$$

$$\sum M_{iB} = 0: R_D 3L - F 2L = 0 \Rightarrow R_D = \frac{2}{3} F$$

$$\sum F_{iy} = 0: R_B + R_D - F = 0 \Rightarrow R_B = \frac{1}{3} F$$

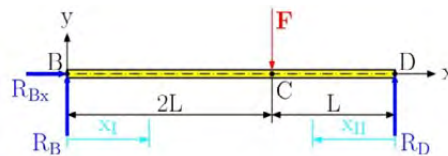
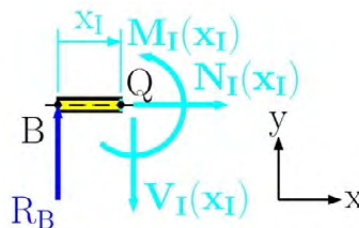


Fig. 5.47



$$x_I \in \langle 0, 2L \rangle$$

Fig. 5.48

Drawing the free-body diagram of portion BQ of the beam (Fig. 5.48) and finding the moment about Q, we can see that

$$\sum M_{iQ} = 0: M_I(x_I) - R_B x_I = 0 \Rightarrow M_I(x_I) = R_B x_I$$

$$M_I(x_I) = \frac{F}{3} x_I$$

(a)

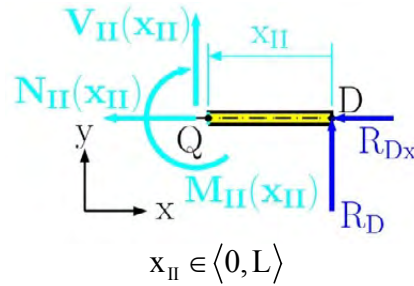


Fig. 5.49

Drawing the free-body diagram of portion QD of the beam (Fig. 5.49) and finding the moment about Q, we find that

$$\sum M_{iQ} = 0: -M_{II}(x_{II}) + R_D x_{II} = 0 \Rightarrow M_{II}(x_{II}) = R_D x_{II}$$

# The Wake

the only emission we want to leave behind

[Low-speed Engines](#) [Medium-speed Engines](#) [Turbochargers](#) [Propellers](#) [Propulsion Packages](#) [PrimeServ](#)

The design of eco-friendly marine power and propulsion solutions is crucial for MAN Diesel & Turbo. Power competencies are offered with the world's largest engine programme – having outputs spanning from 450 to 87,220 kW per engine. Get up front! Find out more at [www.mandieselturbo.com](http://www.mandieselturbo.com)

Engineering the Future – since 1758.

## MAN Diesel & Turbo

$$M_{II}(x_{II}) = \frac{2}{3}F x_{II} \quad (b)$$

In order to find the deflection at point C we must modify Castigliano's theorem in Eq. (5.14) for two portions, which is

$$y_C = \frac{\partial U}{\partial F_C} = \frac{1}{EI} \int_0^{2L} M_I(x_I) \frac{\partial M_I(x_I)}{\partial F} dx_I + \frac{1}{EI} \int_0^L M_{II}(x_{II}) \frac{\partial M_{II}(x_{II})}{\partial F} dx_{II} \quad (c)$$

Substituting Eq. (a) and Eq. (b) into Eq. (c) we have

$$y_C = \frac{1}{EI} \int_0^{2L} \frac{F}{3} x_I \frac{x_I}{3} dx_I + \frac{1}{EI} \int_0^L \frac{2}{3} F x_{II} \frac{2}{3} x_{II} dx_{II}$$

Integrating the last equation, we get the deflection at point C

$$y_C = \frac{F}{9EI} \left[ \frac{x_I^3}{3} \right]_0^{2L} + \frac{4F}{9EI} \left[ \frac{x_{II}^3}{3} \right]_0^L = \frac{4}{9} \frac{FL^3}{EI}$$

### Problem 5.10

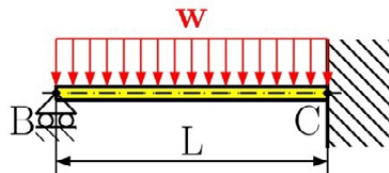


Fig. 5.50

For the uniformly loaded beam shown in Fig. 5.50, determine (a) the reaction at support B applying both Castigliano's theorem and the integration method, (b) the reaction at support B and using the singularity function.

### Solution

This problem is a statically indeterminate one. For its solution we need the boundary condition, which states that the deflection at point B is equal to zero, because in this point we have a rigid support. This support can then be replaced with the unknown reaction  $R_B$ , see Fig. 5.51.

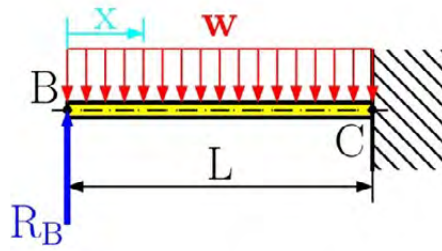


Fig. 5.51

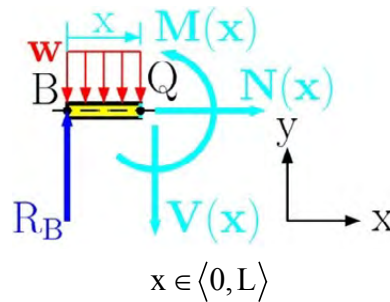


Fig. 5.52

(a) the reaction at support B using Castigliano's theorem and the function of the elastic curve

Drawing the free-body diagram of portion BQ of the beam (Fig. 5.52) and taking into account the moment about Q, we find that

$$\sum M_{iQ} = 0: M(x) - R_B x + wx \frac{x}{2} = 0$$

$$M(x) = R_B x - \frac{wx^2}{2}$$

(a)

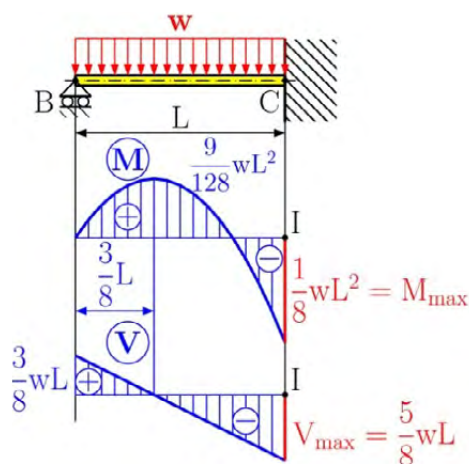


Fig. 5.53

From the equilibrium of forces in the x and y direction we have

$$\sum F_{ix} = 0: N(x) = 0$$

$$\sum F_{iy} = 0: R_B - V(x) - wx = 0 \Rightarrow V(x) = R_B - wx$$

Substitute the bending moment, Eq. (a), into Castigliano's theorem (Eq. 5.14) we obtain the following form

$$y_B = \frac{\partial U}{\partial R_B} = \frac{1}{EI} \int_0^L M(x) \frac{\partial M(x)}{\partial R_B} dx = 0 \quad (b)$$

and we have

$$0 = \frac{1}{EI} \int_0^L \left( R_B x - \frac{wx^2}{2} \right) \frac{\partial}{\partial R_B} \left( R_B x - \frac{wx^2}{2} \right) dx$$

From the solution of the last equation we get

$$R_B = \frac{3}{8} wL. \quad (c)$$

Substituting this into the bending moment of Eq. (a), and the equation for the transversal load, we have

$$M(x) = R_B x - \frac{wx^2}{2} = \frac{3}{8} wLx - \frac{wx^2}{2}$$

$$V(x) = R_B - wx = \frac{3}{8} wL - wx$$

The bending moment and transversal load diagram is shown in Fig. 5.53.

Substituting  $M(x)$  into the elastic curve equation Eq. (5.3)

$$\frac{d^2 y}{dx^2} = \frac{M(x)}{EI} = \frac{1}{EI} \left[ \frac{3}{8} wLx - \frac{wx^2}{2} \right]$$

$$EI \frac{d^2 y}{dx^2} = \frac{3}{8} wLx - \frac{wx^2}{2}$$

and double integrating the last equation with respect to  $x$ , we have

$$EI \frac{dy}{dx} = \frac{3}{16} wLx^2 - \frac{wx^3}{6} + C_1$$

$$EI y(x) = \frac{3}{48} wLx^3 - \frac{wx^4}{24} + C_1x + C_2 \quad (d)$$

The integration constants  $C_1$  and  $C_2$ , are found from the following boundary conditions

1.  $x = L \Rightarrow y(x) = 0$ ,
2.  $x = L \Rightarrow y'(x) = 0$ ,

Note that we cannot use the condition  $x = 0, y = 0$  because this condition was used for the calculation of the reaction at point B and thus the integration constants are

$$C_1 = -\frac{1}{48} wL^3, \quad C_2 = 0$$

## SMS from your computer


...Sync'd with your Android phone & number

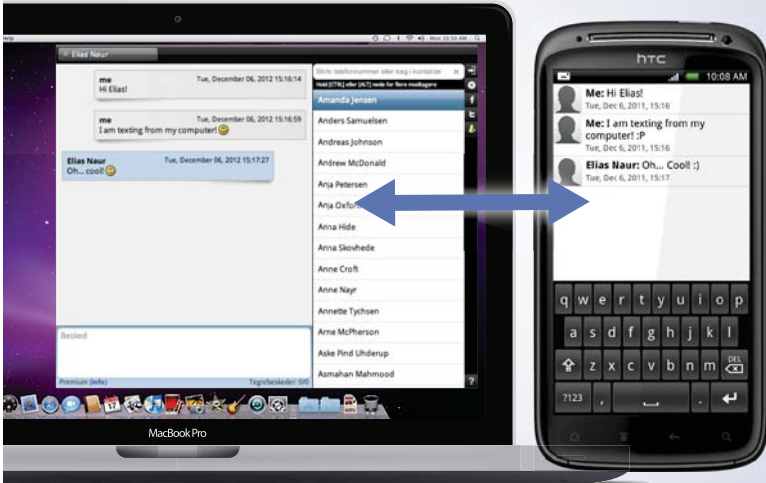
FREE  
30 days trial!

Go to

BrowserTexting.com

and start texting from your computer!





Substituting these into Eq. (d), we have

$$y(x) = \frac{1}{EI} \left[ \frac{3}{48} wLx^3 - \frac{wx^4}{24} - \frac{1}{48} wL^3x \right]$$

(b) the reaction at support B and the elastic curve using the singularity function.

Using Fig. 4.11 we find the bending moment and transversal load with the singularity function

$$M(x) = R_B \langle x \rangle^1 - \frac{w}{2} \langle x \rangle^2$$

$$V(x) = R_B \langle x \rangle^0 - w \langle x \rangle^1$$

Using Eq. (5.3), we write

$$\frac{d^2y}{dx^2} = \frac{M(x)}{EI} = \frac{1}{EI} \left[ R_B \langle x \rangle^1 - \frac{w}{2} \langle x \rangle^2 \right]$$

$$EI \frac{d^2y}{dx^2} = R_B \langle x \rangle^1 - \frac{w}{2} \langle x \rangle^2.$$

Integrating the last expression twice with respect to x we have

$$EI \frac{dy}{dx} = \frac{R_B}{2} \langle x \rangle^2 - \frac{w}{6} \langle x \rangle^3 +$$

$$EI y(x) = \frac{R_B}{6} \langle x \rangle^3 - \frac{w}{24} \langle x \rangle^4 + C_1x + C_2 \quad (e)$$

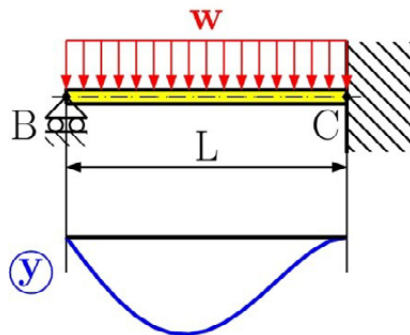


Fig. 5.54

The boundary conditions from Fig. 5.51 are

1.  $x = 0 \Rightarrow v(x) = 0$ ,
2.  $x = L \Rightarrow v(x) = 0$ ,
3.  $x = L \Rightarrow v'(x) = 0$ .

Using all boundary conditions we get

$$C_1 = -\frac{1}{48}wL^3, \quad C_2 = 0, \quad \text{and } R_B = \frac{3}{8}wL.$$

Substituting the integration constants into Eq. (e), we have

$$v(x) = \frac{1}{EI} \left[ \frac{wL}{16} \langle x \rangle^3 - \frac{w}{24} \langle x \rangle^4 - \frac{1}{48} wL^3 x \right]$$

where the bending moment is

$$M(x) = \frac{3}{8}wL \langle x \rangle^1 - \frac{w}{2} \langle x \rangle^2$$

and the transversal load is

$$V(x) = \frac{3}{8}wL \langle x \rangle^0 - w \langle x \rangle^1$$

Diagram of the elastic curve can be seen in Fig. 5.54.

### Problem 5.11

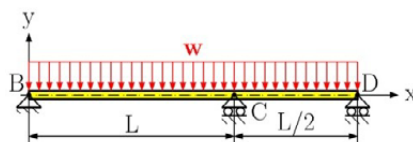


Fig. 5.55

For the beam with the load shown in Fig. 5.55 determine, (a) the reaction at all supports by using Castigliano's theorem, (b) draw the diagram of bending moment and transversal load.

### Solution

The problem is statically indeterminate so we first exchange the support at point C with an unknown reaction  $R_C$ . This reaction is found from the deformation condition, which says that the deflection at point C is equal to zero ( $y_C = 0$ ). (See Fig. 5.56).

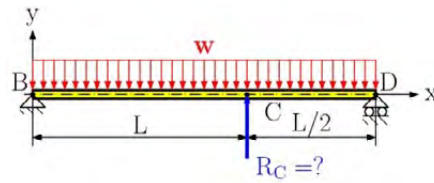


Fig. 5.56

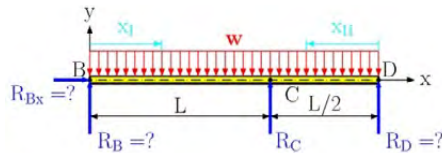


Fig. 5.57

The next step is to now solve for Fig. 5.57, where we consider  $R_C$  to be known. From the free-body diagram in Fig. 5.57 we find the reactions to be a function of the force  $R_C$ , which are

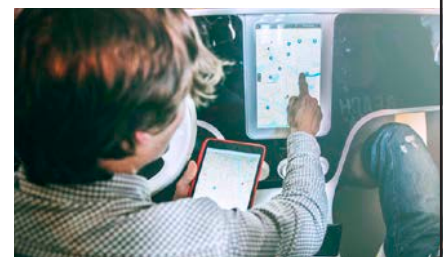
$$\sum F_{ix} = 0: R_{Bx} = 0$$

$$\sum M_{iB} = 0: R_D \frac{3}{2}L - R_C L - w \frac{3}{2}L \frac{3}{4}L = 0$$

**YOUR WORK AT TOMTOM WILL  
BE TOUCHED BY MILLIONS.  
AROUND THE WORLD. EVERYDAY.**

Join us now on [www.TomTom.jobs](http://www.TomTom.jobs)

follow us on **LinkedIn**



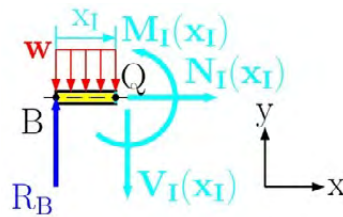
**#ACHIEVEMORE**

**TOMTOM** 

$$R_D = \frac{2}{3}R_C + \frac{3}{4}wL$$

$$\sum F_{iy} = 0: R_B + R_C + R_D - \frac{3}{2}wL = 0$$

$$R_B = \frac{1}{3}R_C + \frac{3}{4}wL$$



$$x_I \in \langle 0, L \rangle$$

Fig. 5.58

Drawing the free-body diagram of portion BQ of the beam (Fig. 5.58) and considering the moment about Q, we find that

$$\sum M_{iQ} = 0: M_I(x_I) - R_B x_I + w x_I \frac{x_I}{2} = 0$$

$$M_I(x_I) = R_B x_I - \frac{w x_I^2}{2} = \left( \frac{1}{3}R_C + \frac{3}{4}wL \right) x_I - \frac{w x_I^2}{2} \tag{a}$$

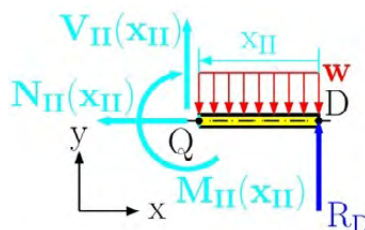
where the normal force is

$$\sum F_{ix} = 0: N_I(x_I) = 0$$

and the transversal force is

$$\sum F_{iy} = 0: R_B - V_I(x_I) - w x_I = 0$$

$$V_I(x_I) = R_B - w x_I = \frac{1}{3}R_C + \frac{3}{4}wL - w x_I \tag{b}$$



$$x_{II} \in \langle 0, L/2 \rangle$$

Fig. 5.59

Drawing the free-body diagram of portion QD of the beam (Fig. 5.59) and considering the moment about Q, we find that

$$\sum M_{iQ} = 0: -M_{II}(x_{II}) + R_D x_{II} - w x_{II} \frac{x_{II}}{2} = 0$$

$$M_{II}(x_{II}) = \left( \frac{2}{3} R_C + \frac{3}{4} wL \right) x_{II} - \frac{w x_{II}^2}{2} \quad (c)$$

The normal force at portion QD is

$$\sum F_{ix} = 0: N_{II}(x_{II}) = 0$$

and the transversal force at portion QD is

$$\sum F_{iy} = 0: R_D + V_{II}(x_{II}) - w x_{II} = 0$$

$$V_{II}(x_{II}) = -R_D + w x_{II} = -\left( \frac{2}{3} R_C + \frac{3}{4} wL \right) + w x_{II} \quad (d)$$

Now we use the deformation condition by Castigliano's theorem which says

$$v_C = \frac{\partial U}{\partial R_C} = \frac{1}{EI} \int_{(L)} M(x) \frac{\partial M(x)}{\partial R_C} dx = 0$$

For two portions we write

$$0 = \frac{1}{EI} \int_0^{2L} M_I(x_I) \frac{\partial M_I(x_I)}{\partial R_C} dx_I + \frac{1}{EI} \int_0^L M_{II}(x_{II}) \frac{\partial M(x_{II})}{\partial R_C} dx_{II} \quad (e)$$

and substitute Eq. (a) and Eq. (c) into Eq. (e), to get

$$0 = \frac{1}{EI} \int_0^L \left\{ \left( \frac{1}{3} R_C + \frac{3}{4} wL \right) x_I - \frac{wx_I^2}{2} \right\} \frac{x_I}{3} dx_I + \frac{1}{EI} \int_0^{L/2} \left\{ \left( \frac{2}{3} R_C + \frac{3}{4} wL \right) x_{II} - \frac{wx_{II}^2}{2} \right\} \frac{2}{3} x_{II} dx_{II}$$

Solving for the last equation we get

$$R_C = -\frac{33}{32} wL. \quad (f)$$

While the other reactions are

$$R_B = \frac{1}{3} \left( -\frac{33}{32} wL \right) + \frac{3}{4} wL = +\frac{13}{32} wL,$$

$$R_D = \frac{2}{3} \left( -\frac{33}{32} wL \right) + \frac{3}{4} wL = +\frac{1}{16} wL$$

(b) draw the diagram of bending moment and transversal load



**Brain power**

By 2020, wind could provide one-tenth of our planet's electricity needs. Already today, SKF's innovative know-how is crucial to running a large proportion of the world's wind turbines.

Up to 25 % of the generating costs relate to maintenance. These can be reduced dramatically thanks to our systems for on-line condition monitoring and automatic lubrication. We help make it more economical to create cleaner, cheaper energy out of thin air.

By sharing our experience, expertise, and creativity, industries can boost performance beyond expectations. Therefore we need the best employees who can meet this challenge!

The Power of Knowledge Engineering

Plug into The Power of Knowledge Engineering.  
Visit us at [www.skf.com/knowledge](http://www.skf.com/knowledge)

**SKF**

The bending moment of portion BC is

$$M_I(x_I) = \frac{13}{32} wLx_I - \frac{wx_I^2}{2}$$

and the transversal load is

$$V_I(x_I) = \frac{1}{3} R_C + \frac{3}{4} wL - wx_I$$

The position of the local extreme for the bending moment is found from the transversal load, which is equal to zero in the extreme position

$$V_I(x_I = x_{\text{ext}}) = \frac{13}{32} wL - wx_{\text{ext}} = 0 \Rightarrow x_{\text{ext}} = \frac{13}{32} L$$

The bending moment in the extreme position is

$$M_I(x_I = x_{\text{ext}}) = \frac{169}{2048} wL^2$$

Bending moment of portion CD is

$$M_{II}(x_{II}) = \frac{1}{16} wLx_{II} - \frac{wx_{II}^2}{2}$$

transversal load is

$$V_{II}(x_{II}) = -\frac{1}{16} wL + wx_{II}$$

The position of the bending moments local extreme is found from the transversal load, which is equal to zero at the extreme.

$$V_{II}(x_{II} = x_{\text{ext}}) = -\frac{1}{16} wL + wx_{\text{ext}} = 0 \Rightarrow x_{\text{ext}} = \frac{1}{16} L$$

The bending moment in the extreme position is

$$M_{II}(x_{II} = x_{\text{ext}}) = \frac{1}{16} wL \frac{L}{16} - \frac{w}{2} \left( \frac{L}{16} \right)^2 = \frac{1}{512} wL^2$$

The bending moment and transversal load diagram can be seen in Fig. 5.60.

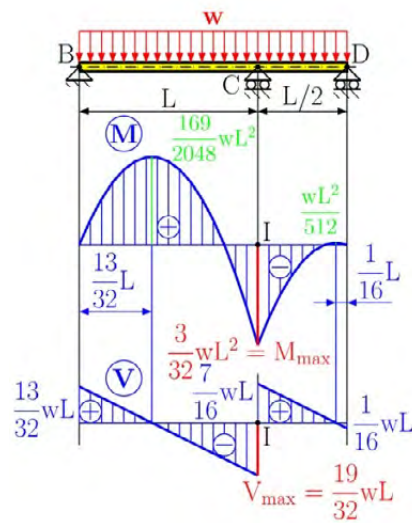


Fig. 5.60

**Problem 5.12**

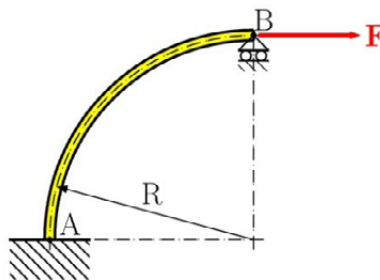


Fig. 5.61

For the curved beam, loaded at its end, see Fig. 5.61, determine, (a) the reaction at all supports by using Castigliano's theorem, (b) the diagram for the bending moment, transversal and normal load.

**Solution**

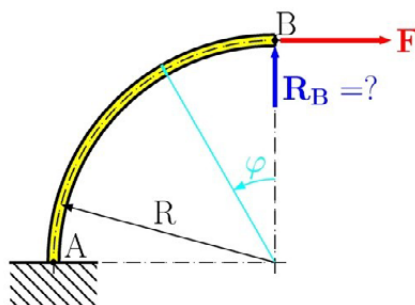


Fig. 5.62

This problem is statically indeterminate so we must convert it to the statically determinate problem by representing the roller support by an unknown reaction  $R_B$  in Fig. 5.62. We find this reaction from the boundary condition that the deflection in this point is equal to zero.

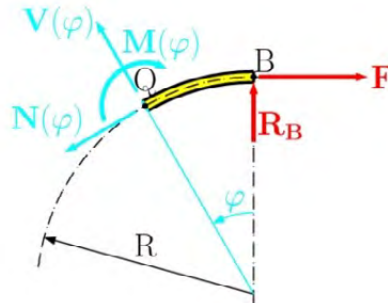


Fig. 5.63

Drawing the free-body diagram of portion BQ of the curved beam (Fig. 5.63 or Fig. 5.64) and considering the moment about Q, we find that

$$\sum M_{iQ} = 0: -M(\varphi) + R_B R \sin \varphi - FR(1 - \cos \varphi) = 0$$

$$M(\varphi) = R_B R \sin \varphi - FR(1 - \cos \varphi). \quad (a)$$

> **Apply now**

REDEFINE YOUR FUTURE  
**AXA GLOBAL GRADUATE  
PROGRAM 2015**

redefining / standards 

agence.cdg. © Photonistop

The force  $2F$  and  $R_B$  decompose to a new coordinate system represented in Fig. 5.64 with equilibrium in the  $x'y'$  coordinate system, finding normal load

$$\sum F_{ix'} = 0: -N(\varphi) + F \cos \varphi + R_B \sin \varphi = 0$$

$$N(\varphi) = F \cos \varphi + R_B \sin \varphi \quad (b)$$

and transversal load

$$\sum F_{iy'} = 0: V(\varphi) - F \sin \varphi + R_B \cos \varphi = 0$$

$$V(\varphi) = F \sin \varphi - R_B \cos \varphi. \quad (c)$$

then defining the strain energy within cylindrical coordinates we get

$$U = \int_{(\varphi)} \frac{M(\varphi)^2}{2EI} R d\varphi \quad (d)$$

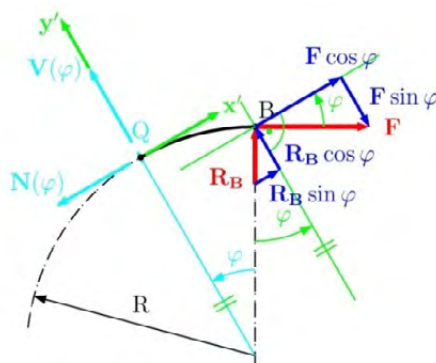


Fig. 5.64

Castilano's theorem in cylindrical coordinates becomes

$$y_B = \frac{\partial U}{\partial R_B} = \frac{1}{EI} \int_0^{2\varphi} M(\varphi) \frac{\partial M(\varphi)}{\partial R_B} R d\varphi. \quad (e)$$

while the deformation condition using Eq. (e) is as follows

$$y_B = \frac{\partial U}{\partial R_B} = \frac{1}{EI} \int_0^{2\varphi} M(\varphi) \frac{\partial M(\varphi)}{\partial R_B} R d\varphi = 0.$$

Substituting Eq. (a) into our equation, we have

$$\int_0^{\delta/2} [R_B R \sin \varphi - FR(1 - \cos \varphi)] R \sin \varphi \, d\varphi = 0,$$

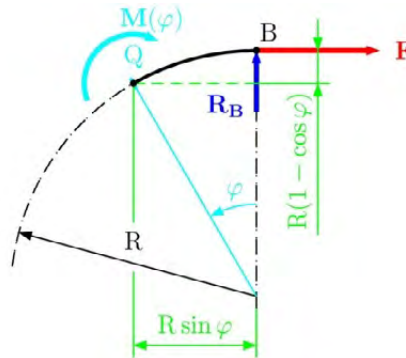


Fig. 5.65

and we find the reaction at point B as

$$R_B = \frac{2}{\pi} F. \quad (f)$$

Substituting Eq. (f) into Eq. (a), Eq. (b) and Eq. (c) we get

$$M(\varphi) = \frac{2}{\pi} FR \sin \varphi - FR(1 - \cos \varphi)$$

$$V(\varphi) = F \sin \varphi - \frac{2}{\pi} F \cos \varphi$$

$$N(\varphi) = F \cos \varphi + \frac{2}{\pi} F \sin \varphi$$

The diagram of the bending moment is shown in Fig. 5.66 where the local extreme is found from the transversal load when its value is equal to zero

$$V(\varphi_{\text{ext}}) = F \sin \varphi_{\text{ext}} - \frac{2}{\pi} F \cos \varphi_{\text{ext}} = 0$$

$$\tan \varphi_{\text{ext}} = \frac{2}{\pi} \Rightarrow \varphi_{\text{ext}} = \arctan\left(\frac{2}{\pi}\right) = 32.48^\circ$$

The value of the bending moment in the extreme is

$$M(32.48^\circ) = \frac{2}{\pi} FR \sin 32.48^\circ - FR(1 - \cos 32.48^\circ)$$

$$M(32.48^\circ) = 0.186FR$$

The transversal force diagram is shown in Fig. 5.67 and the diagram of normal force is shown in the Fig. 5.68.

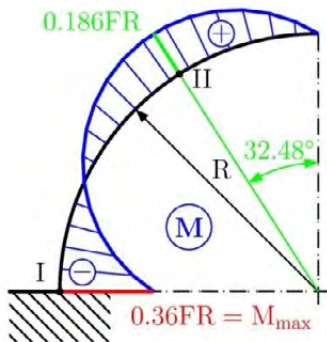


Fig. 5.66

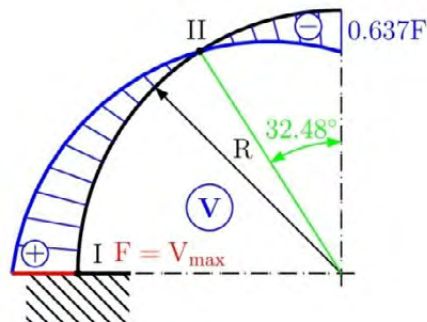


Fig. 5.67

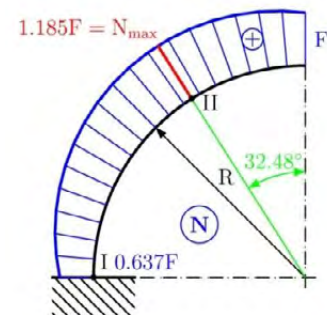


Fig. 5.68

## LIGS University

based in Hawaii, USA

is currently enrolling in the  
Interactive Online **BBA, MBA, MSc,**  
**DBA and PhD** programs:

- ▶ enroll **by October 31st, 2014** and
- ▶ **save up to 11%** on the tuition!
- ▶ pay in 10 installments / 2 years
- ▶ Interactive **Online** education
- ▶ visit [www.ligsuniversity.com](http://www.ligsuniversity.com) to find out more!

Note: LIGS University is not accredited by any nationally recognized accrediting agency listed by the US Secretary of Education. More info [here](#).



## Unsolved problems

## Problem 5.12

For the beam loading according to Fig. 5.69, determine (a) the reaction at the supports, (b) the deflection at point C, (c) the slope at point B. Use the following parameters:  $E = 210 \text{ GPa}$ ,  $I = 8.2 \cdot 10^{-7} \text{ m}^4$ .

$$[R_{Bx} = 0, R_B = 2500 \text{ N}, R_D = 500 \text{ N}, y_C = -1.47 \text{ mm}, \Theta_B = -0.0036 \text{ rad}]$$

## Problem 5.13

For the beam and loading shown in Fig. 5.70, determine (a) the reaction at the supports, (b) the deflection at point C, (c) the slope at point B. Assume:  $E = 210 \text{ GPa}$ ,  $I = 7.2 \cdot 10^{-7} \text{ m}^4$ .

$$[R_{Bx} = 0, R_B = 5281.82 \text{ N}, R_D = 5118.18 \text{ N}, y_C = -14.1 \text{ mm}, \Theta_D = -0.021 \text{ rad}]$$

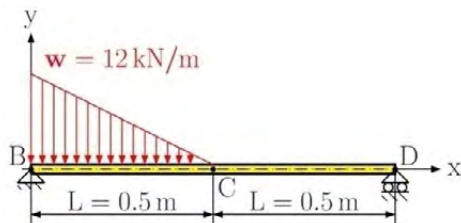


Fig. 5.69

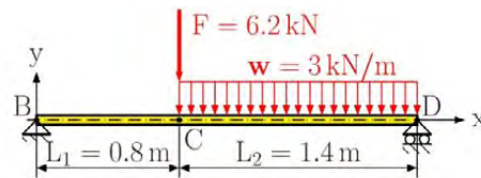


Fig. 5.70

## Problem 5.14

For beam and load shown in Fig. 5.71, determine (a) the reactions at the supports, (b) the deflection at point D, (c) the slope at point B.

$$\left[ R_{Bx} = 0, R_B = -\frac{1}{4}wL, R_C = \frac{5}{4}wL, y_D = -\frac{35}{24} \frac{wL^4}{EI}, \Theta_B = \frac{1}{6} \frac{wL^3}{EI} \right]$$

## Problem 5.15

For the beam which is loaded according to Fig. 5.72, determine (a) the reaction at the supports, (b) the deflection at point C, (c) the slope at point C.

$$\left[ R_{Bx} = 0, R_B = \frac{M_o}{L}, R_C = -\frac{M_o}{L}, y_C = 0, \Theta_C = \frac{1}{12} \frac{M_o L}{EI} \right]$$

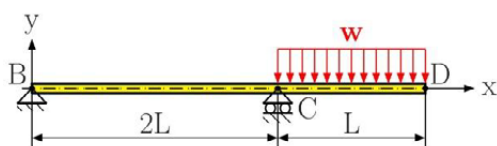


Fig. 5.71

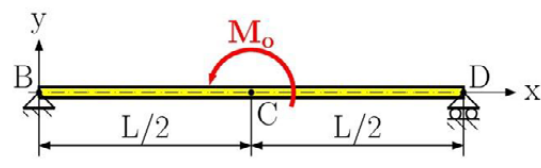


Fig. 5.72

**Problem 5.16**

For the beam and load shown in Fig. 5.73, determine (a) the reaction at the roller support, (b) the deflection at point C.

$$\left[ R_B = -\frac{9}{8} \frac{M_o}{L}, y_C = \frac{1}{128} \frac{M_o L^2}{EI} \right]$$

**Problem 5.17**

For the beam and load shown in Fig. 5.74, determine (a) the reaction at the roller support, (b) the deflection at point C.

$$\left[ R_B = \frac{2}{3} F, y_C = -\frac{5}{486} \frac{FL^3}{EI} \right]$$

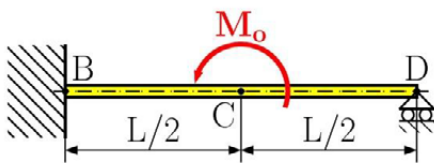


Fig. 5.73

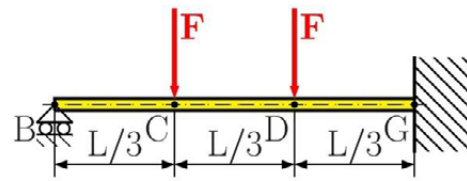


Fig. 5.74

**Problem 5.18**

For the beam subjected to the moment in Fig. 5.75, determine (a) the reaction at point B, (b) the deflection at point C.

$$\left[ R_B = \frac{3}{2} \frac{M_o}{L}, M_B = \frac{M_o}{4}, y_C = -\frac{1}{96} \frac{M_o L^2}{EI} \right]$$

**Problem 5.19**

For beam with the loading shown in Fig. 5.78, determine (a) the reaction at point B, (b) the deflection at point C.

$$\left[ R_B = \frac{32}{25} wL, M_B = \frac{4}{3} wL^2, y_C = -\frac{34}{75} \frac{wL^4}{EI} \right]$$

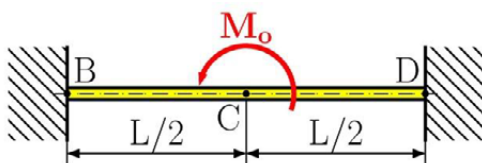


Fig. 5.75

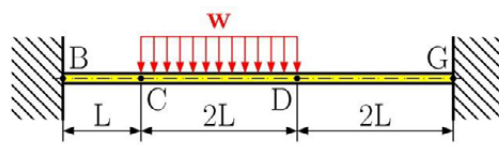


Fig. 5.76

**Problem 5.20**

For the beam with the load shown in Fig. 5.77, determine (a) the reaction at point C, (b) the deflection at point C.

$$\left[ R_c = \frac{3}{16} wL, y_c = -\frac{1}{16} \frac{wL^4}{EI} \right]$$

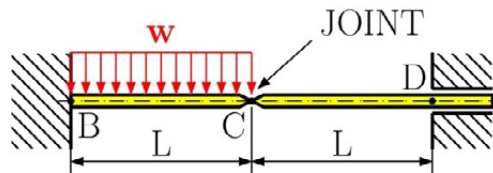


Fig. 4.77

## TURN TO THE EXPERTS FOR SUBSCRIPTION CONSULTANCY

Subscribe is one of the leading companies in Europe when it comes to innovation and business development within subscription businesses.

We innovate new subscription business models or improve existing ones. We do business reviews of existing subscription businesses and we develop acquisition and retention strategies.

Learn more at [linkedin.com/company/subscribe](https://www.linkedin.com/company/subscribe) or contact Managing Director Morten Suhr Hansen at [mha@subscribe.dk](mailto:mha@subscribe.dk)

**SUBSCR**✓**BE** - to the future

# 6 Columns

## 6.1 Introduction

Until now we have dealt with the analysis of stress and strain in structures acted on by specified loads without any unacceptable deformations in the elastic region. Sometimes the structure can suddenly change its configuration at a certain load level. After removing the load, the structure will return to its initial configuration according to the condition of elastic response. The sudden change in configuration represents the *unstable mode* of the structure deformation. To exclude unstable modes of deformations, we need to gain knowledge about the *stability* of structures. That is, to determine the *critical load* which corresponds to the initiation of the unstable deformation modes.

In this Chapter we are going to analyse only simple structures, in our case columns.

## 6.2 Stability of Structures

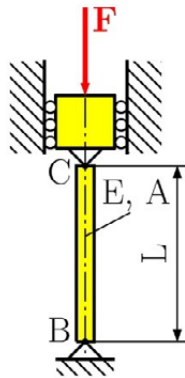


Fig. 6.1

Let us consider a column  $BC$  of length  $L$  with a pin connection at both ends, see Fig. 6.1. This column is acted on by the centric axial compressive force  $F$ . Let us suppose that the design of the considered column satisfies the strength condition  $\sigma_{max} \leq \sigma_{All}$  and its deformation  $\Delta L = FL/EA$  falls within the given specification. What this means is that the column is designed properly. However, it might happen that the column will lose stability and *buckle* and instead of remaining straight it will suddenly curve sharply, see Fig. 6.2.

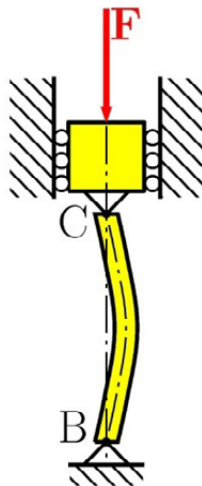


Fig. 6.2

To understand the process of buckling, let us build a simple model of our column  $BC$ . This column consists of two rigid rods  $BD$  and  $CD$  connected together at point  $D$  by a pin and the torsional spring characterised by the spring constant  $K$ , see Fig. 6.3. If the applied load is perfectly aligned with the rods, the presented system remains straight and stable, see Fig. 6.4(a). But if we move point  $D$  to the right slightly, the rods will form a small angle  $\Delta\theta$ , see Fig. 6.4(b). This state is unstable because, after removing the applied load, the system will return to the initial stable mode by the action of the torsional spring. It is not possible to find the critical load  $F_{CR}$  from the unbuckled state, therefore we must analyse the buckled structure. For simplicity let us consider rod  $CD$  only, see Fig. 6.5. We can observe two couples acting on the rod considered, namely the couple caused by forces  $F$  and  $F'$  and the couple  $M = K2\Delta\theta$  exerted by the spring. If the couple of forces  $F$  and  $F'$  is smaller than the couple  $M$ , then the system tends to be in its initial stable configuration, i.e. in the equilibrium position. If couple  $M$  is smaller than the force couple  $F$  and  $F'$ , then the system tends to move away from the equilibrium position to the unstable configuration. If both couples are in equilibrium, then the corresponding load is the critical load  $F_{CR}$ . Then we can write

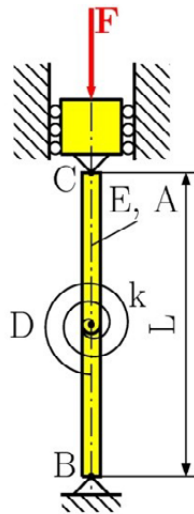


Fig. 6.3

“I studied English for 16 years but...  
...I finally learned to speak it in just six lessons”  
Jane, Chinese architect

ENGLISH OUT THERE

Click to hear me talking before and after my unique course download

The advertisement features a woman, Jane, a Chinese architect, smiling. To her right is a green speech bubble containing the text 'ENGLISH OUT THERE'. Below the speech bubble is a call to action: 'Click to hear me talking before and after my unique course download'. A hand cursor icon is positioned over the call to action.

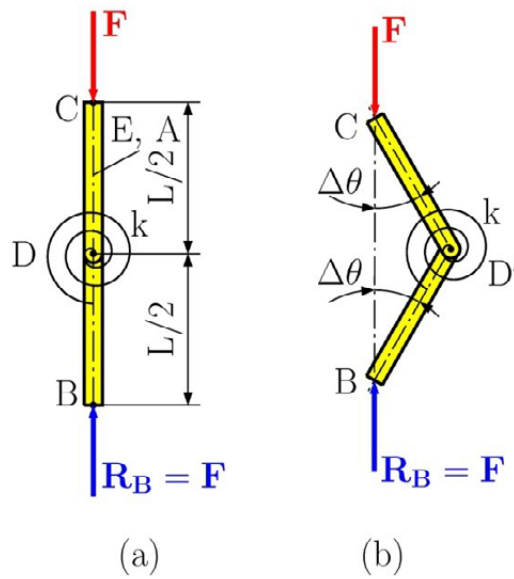


Fig. 6.4

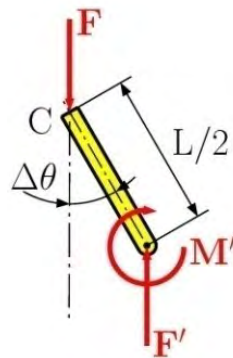


Fig. 6.5

$$F_{cr} \left(\frac{L}{2}\right) \sin \Delta\theta = K2\Delta\theta \tag{6.1}$$

Assuming a small angular change where  $\Delta\theta \cong \Delta\theta$  we get

$$F_{cr} = \frac{4K}{L} \tag{6.2}$$

For the load  $F < F_{cr}$  the structure is in a stable state, i.e. there is no buckling. For an applied load of  $F > F_{cr}$  the structure is in an unstable state, i.e. the structure can buckle. Assuming the applied load  $F > F_{cr}$  the structure moves away from equilibrium and, after some oscillations, will settle in to its new equilibrium position which will be different from its previous one. For this reason the simplification of  $\sin \Delta\theta \cong \Delta\theta$  cannot be valid anymore. Thus we need to solve the non-linear equation

$$F \left(\frac{L}{2}\right) \sin \Delta\theta = K2\Delta\theta \tag{6.3}$$

or

$$\frac{FL}{4K} = \frac{\Delta\theta}{\sin \Delta\theta} \quad (6.4)$$

The last equation represents the problem of buckling equilibrium. This is out of our interest. We always try to design structures which resist to buckling.

### 6.3 Euler's formulas for Columns

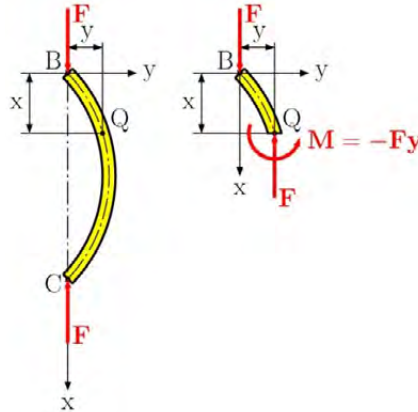


Fig. 6.6

Let us consider the column  $BC$  of the length  $L$  with a pin connection at both ends, see Fig. 6.1 again. This column is subjected to the centric axial compressive force  $F$ . Our task is to determine the critical load  $F_{CR}$ , which causes buckling. Therefore we need to analyse the deformed rod, see Fig. 6.6. It can be assumed that the column is a vertical beam. Then, applying the step-by-step approach, we can determine the internal forces acting at the arbitrary point  $Q$ . The shape of the buckled column can be described as an elastic curve. Mathematically we get

$$\frac{d^2y}{dx^2} = \frac{M(x)}{EI} = -\frac{Fy}{EI} \quad (6.5)$$

or

$$\frac{d^2y}{dx^2} + \frac{Fy}{EI} = 0 \quad (6.6)$$

Assuming that  $p^2 = F/EI$  we obtain

$$\frac{d^2y}{dx^2} + p^2y = 0 \quad (6.7)$$

The general solution of the above equation has the form

$$y(x) = A \sin px + B \cos px \quad (6.8)$$

The integration constants  $A$  and  $B$  can be determined from the boundary conditions, which must be satisfied at both ends. Firstly we make  $x = 0$  then  $y = 0$  and we find that  $B = 0$ . Secondly we make  $x = L$  then  $y = 0$  and we find that

$$A \sin pL = 0 \quad (6.9)$$

This equation either has the solution  $A = 0$ , which does not make physical sense, or  $\sin pL = 0$ . If  $\sin pL = 0$  then  $pL = n\pi$ . Substituting for  $p^2 = F/EI$  and solving, we get

$$F = \frac{n^2 \pi^2 EI}{L^2} \quad (6.10)$$

The smallest value of the load  $F$  defined by the equation (6.10) is corresponding to  $n = 1$ , thus we obtain the critical load

$$F_{cr} = \frac{\pi^2 EI}{L^2} \quad (6.10)$$

The expression above is well-known as *Euler's formula*, Euler (1707–1783). Substituting Euler's formula into  $p^2 = F/EI$  and then into equation (6.8) we have

**wethrive.net**

**How to retain your top staff**

**FIND OUT NOW FOR FREE**

**DO YOU WANT TO KNOW:**

- What your staff really want?
- The top issues troubling them?
- How to make staff assessments work for you & them, painlessly?

**Get your free trial**

Because happy staff get more done

$$y(x) = A \sin \frac{\pi}{L} x \quad (6.11)$$

This is the elastic curve of a beam after it has buckled. The constant  $A$  can be determined from the condition  $y_{max} = A$ .

The corresponding critical stress can be calculated as

$$\sigma_{cr} = \frac{F_{cr}}{A} = \frac{\pi^2 EI}{AL^2} \quad (6.12)$$

Setting  $I = Ar^2$ , where  $r$  is the radius of gyration. Then we obtain

$$\sigma_{cr} = \frac{\pi^2 EI}{AL^2} = \frac{\pi^2 EAr^2}{AL^2} = \frac{\pi^2 E}{(L/r)^2} = \frac{\pi^2 E}{(\lambda)^2} \quad (6.13)$$

The quantity  $\lambda = L/r$  is the *slenderness ratio*.

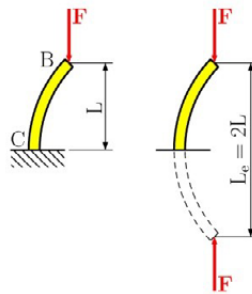


Fig. 6.7

The validity of Euler's formula can be extended to columns with different supports. Therefore we can introduce the effective length  $L_e$ , which generalises pin-ended columns with other types of columns. Thus we can express the critical load and stress as follows

$$F_{cr} = \frac{\pi^2 EI}{L_e^2} \quad \text{and} \quad \sigma_{cr} = \frac{\pi^2 E}{(L_e/r)^2} = \frac{\pi^2 E}{(\lambda_e)^2} \quad (6.14)$$

The quantity  $\lambda_e = L_e/r$  is the *effective slenderness ratio*.

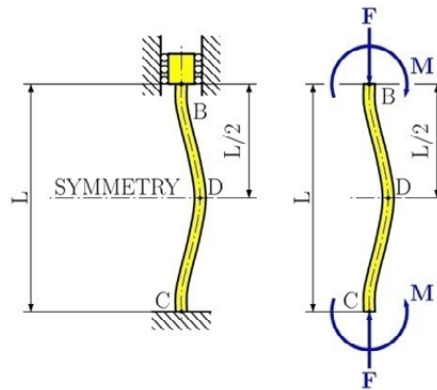


Fig. 6.8

Let us consider a column  $BC$  of length  $L$ , fixed at  $C$ , and free at  $B$ , see Fig. 6.7. In this case we observe that the column will behave like the upper part of the pin-ended column with an effective length of  $L_e = 2L$ , and an effective slenderness ratio of  $\lambda_e = 2L/r$ .

Now considering the column  $BC$  of length  $L$  with both ends fixed, see Fig. 6.8. Then, due to the horizontal symmetry at the point  $D$ , we get horizontal reactions at the supports which must be equal to zero. The vertical tangents at points  $B, C, D$  to the elastic curve have zero slopes. Therefore there exists two inflexion points  $E, F$ , where the bending moments are equal to zero, see Fig. 6.9. For the pin-ended column, the bending moments at the supports are equal to zero too. Thus portion  $EF$  of the column behaves like the pin-ended column with an effective length of  $L_e = L/2$ , and an effective slenderness ratio of  $\lambda_e = L/2r$ .

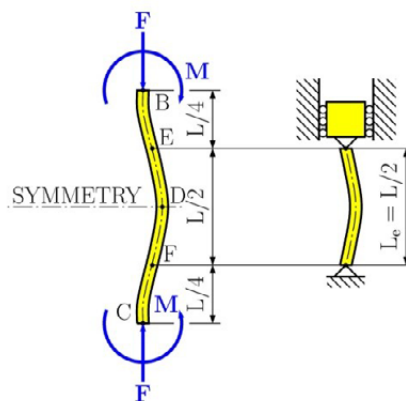


Fig. 6.9

Finally let us consider column  $BC$  of length  $L$  with one fixed end  $C$  and one pinned end  $B$ , see Fig. 6.10. In this case we must write the differential equation of the elastic curve in order to determine the effective length. Therefore drawing the free body diagram with corresponding boundary equations, see Fig. 6.11, then applying the method of section in order to obtain the bending moment at any arbitrary point  $Q$ , we have

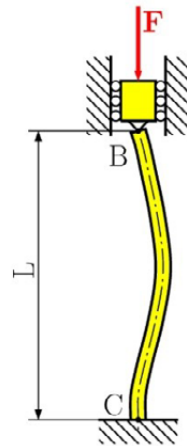


Fig. 6.10

$$M(x) = -Fy - Vx \tag{6.15}$$

**gaiteye**  
Challenge the way we run

**EXPERIENCE THE POWER OF FULL ENGAGEMENT...**

.....

**RUN FASTER.  
RUN LONGER..  
RUN EASIER...**

**READ MORE & PRE-ORDER TODAY  
WWW.GAITEYE.COM**

substituting into equation (6.5) we get the differential equation of the elastic curve

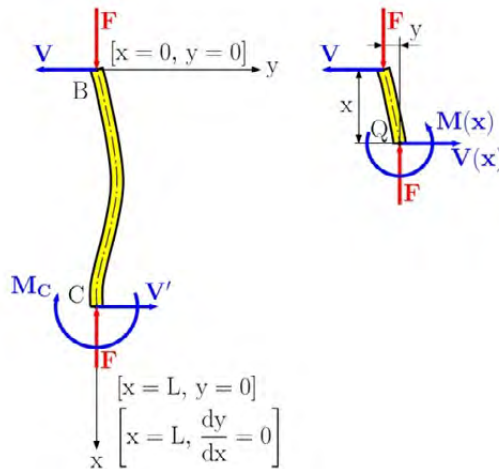


Fig. 6.11

$$\frac{d^2y}{dx^2} = \frac{M(x)}{EI} = \frac{-Fy - Vx}{EI} = -\frac{Fy}{EI} - \frac{Vx}{EI} \quad (6.16)$$

or

$$\frac{d^2y}{dx^2} + \frac{Fy}{EI} = -\frac{Vx}{EI} \quad (6.17)$$

or

$$\frac{d^2y}{dx^2} + p^2y = -\frac{Vx}{EI} \quad (6.18)$$

Solving this equation requires the addition of solutions of the homogeneous equation (6.6) and the particular solution of the non-homogeneous equation. The particular solution is determined by the order of the polynomial function on the right side of equation (6.18). One can easily derive that this particular solution is

$$y_{part} = -\frac{V}{p^2EI}x = -\frac{V}{F}x \quad (6.19)$$

Then the general solution of the equation (6.18) has the form

$$y(x) = A \sin px + B \cos px - \frac{V}{F}x \quad (6.20)$$

This equation contains three unknowns:  $A$ ,  $B$ ,  $V$ . Applying the boundary condition for point  $B$  as  $x = 0$  then  $y = 0$  we find that  $B = 0$ . Making the next conditions as  $x = L$ ,  $y = 0$  and  $\frac{dy}{dx} = 0$  we obtain

$$A \sin pL = \frac{V}{F} L \quad (6.21)$$

and

$$Ap \cos pl = \frac{V}{F} L \quad (6.22)$$

Dividing equation (6.21) by equation (6.22) we get

$$\tan pl = pl \quad (6.23)$$

Solving the above equation can be done by Newton's iterative method, (for more details see A. Ralston et al: A First Course in Numerical Analysis), as follows

$$pl = 4.4934 \quad (6.24)$$

Using  $p^2 = F/EI$  and solving for the critical load we get

$$F_{cr} = \frac{20.19EI}{L^2} \quad (6.25)$$

The effective length can be obtained by equating the right-hand sides of the equations (6.25) and (6.14)

$$\frac{\pi^2 EI}{L_e^2} = \frac{20.19EI}{L^2} \quad (6.26)$$

Solving this equation, we obtain the effective length for this case  $L_e = 0.699L \cong 0.7L$ .

Then we can summarise the effective lengths for the various end conditions considered in this Section, see Fig. 6.12.

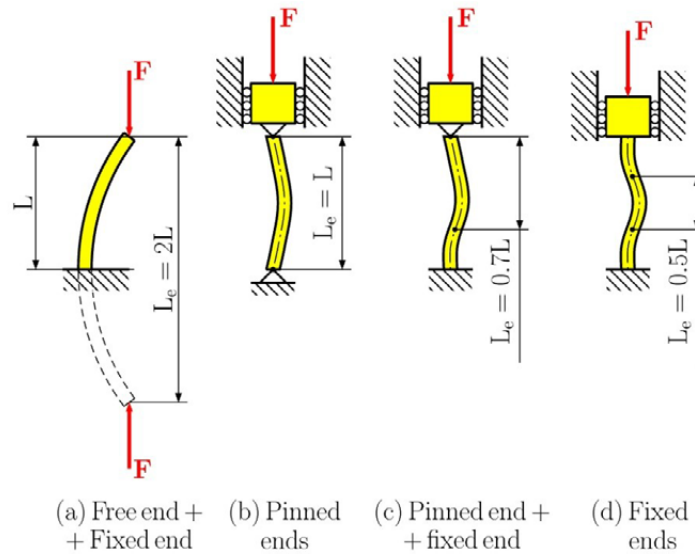


Fig. 6.12

#### 6.4 Design of Columns under a Centric Load

In the previous Section we have derived a formula for calculating the critical stress as

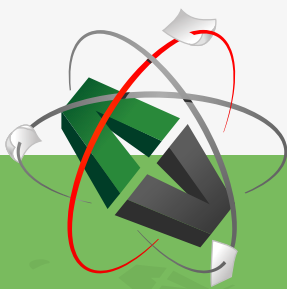
$$\sigma_{cr} = \frac{\pi^2 E}{(\lambda)^2} \quad (6.27)$$

This e-book  
is made with  
**SetaPDF**



PDF components for PHP developers

[www.setasign.com](http://www.setasign.com)



Click on the ad to read more

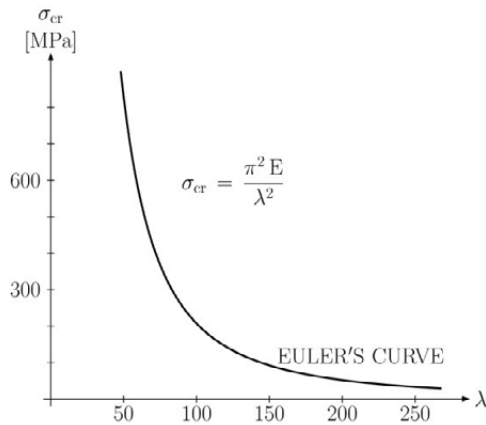


Fig. 6.13

This equation shows that the critical stress is proportional to Young’s modulus of the column material, and inversely proportional to the square of the slenderness ratio of the column. For a certain material, i.e. for a given Young’s modulus, we will get the plot of the critical stress versus the slenderness ratio, see Fig. 6.13. It is clear that for short columns, with low slenderness ratios, that the critical stress can exceed both: the ultimate stress and the yield stress before reaching Euler’s critical stress. Therefore we must modify the plot of the critical stress versus the slenderness ratio. For the illustration let us consider steel with a Young’s modulus of  $E = 210 \text{ GPa}$ , the ultimate stress  $\sigma_U = 190 \text{ MPa}$ , and the yield stress  $\sigma_Y = 240 \text{ MPa}$ . Assuming that  $\sigma_{cr} = \sigma_U$  we can derive the minimum slenderness ratio

$$\lambda_{min} = \pi \sqrt{\frac{E}{\sigma_U}} = \pi \sqrt{\frac{210000 \text{ MPa}}{190 \text{ MPa}}} \cong 104$$

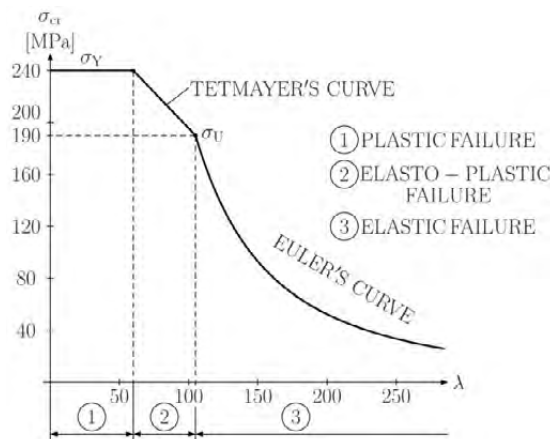


Fig. 6.14

If the current stress is greater than the critical stress  $\sigma_{cr}$ , i.e.  $\lambda < \lambda_{min}$ , then the material behaviour is not elastic and we cannot apply Euler's formula. For short columns which  $\lambda < \lambda_{min}$ , the critical load  $F_{cr}$  is determined empirically using experimental results. These experimental results can be approximated by Tetmayer's curve (L. Tetmayer 1850–1905)

$$\sigma_{cr} = a - \lambda b \quad (6.28)$$

where  $a, b$  are the material constants. Then we get the limit curve of the critical stress versus the slenderness ratio consisting of three regions, see Fig. 6.14. Region 1, limited by the yielding stress  $\sigma_y$ , is valid for short columns. Region 2, limited by Tetmayer's curve, is valid for intermediate columns and region 3, limited by Euler's curve, is valid for long columns.

For the design of columns, we apply the *buckling coefficients*. These coefficients are determined by STN standards for a given material with a corresponding slenderness ratio. Thus the strength condition  $\sigma_{max} \leq \sigma_{All}$  must be modified as

$$\sigma_{max} \leq \frac{\sigma_{All}}{B.C.} \quad (6.29)$$

where  $B.C.$  is the buckling coefficient. Thus we can determine the allowable stress for centric loading to be

$$\frac{\sigma_{All}}{B.C.} = (\sigma_{All})_{centric} \quad (6.30)$$

## 6.5 Design of Columns under an Eccentric Load

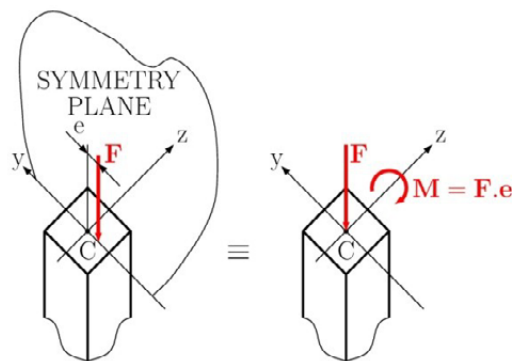


Fig. 6.15

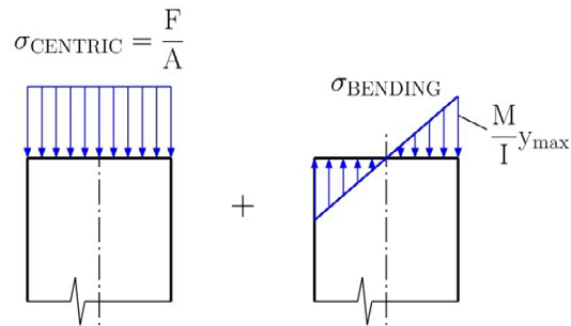


Fig. 6.16

In this section we discuss the design of columns undergoing eccentric loading. Let us consider an eccentric load applied in the plane of a column's symmetry at an eccentricity of  $e$ , see Fig. 6.15. This eccentric load  $F$  can be replaced with the axial force  $F$  and the couple  $M = Fe$ . Then the normal stress exerted on the transverse section of the considered column can be expressed by superposing the axial load  $F$  and the couple  $M$ , see Fig. 6.16. This is valid only if the conditions of Saint Venant's principle are satisfied and as long as the stresses involved do not exceed the proportional limit of the material. We can then write the stress caused by the eccentric load to be

$$\sigma = \sigma_{centric} + \sigma_{bending} \quad (6.31)$$



Discover the truth at [www.deloitte.ca/careers](http://www.deloitte.ca/careers)

**Deloitte.**

© Deloitte & Touche LLP and affiliated entities.

The maximum compressive stress can be calculated as

$$\sigma_{max} = \frac{F}{A} + \frac{M}{I} y_{max} \quad (6.32)$$

This maximum stress can not exceed the allowable stress in a properly designed column. To satisfy this requirement we can apply two approaches: the *allowable stress method* or the *interaction method*.

*The allowable stress method.* This method is based on the assumption that the allowable stress for centric loading is equal to the allowable eccentric loading. The design of the column must satisfy the strength condition  $\sigma_{max} \leq \sigma_{All}$ , where  $\sigma_{All} = \frac{\sigma_U}{F.S.}$ . Then combining with the equation (6.32) we get

$$\frac{F}{A} + \frac{M}{I} y_{max} \leq \sigma_{All} \quad (6.33)$$

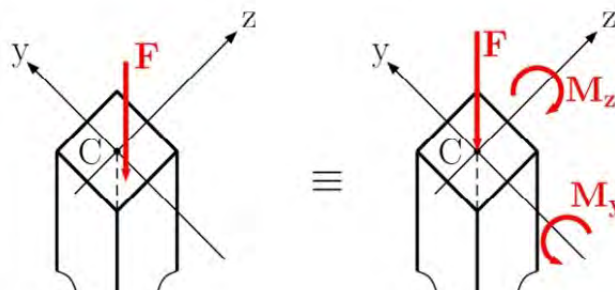


Fig. 6.17

*The interaction method.* This method is based on the assumption that the allowable stress for centric loading is smaller than the allowable stress for bending. Therefore let us modify equation (6.33) by dividing the value of allowable stress to obtain

$$\frac{F/A}{\sigma_{All}} + \frac{M/I}{\sigma_{All}} y_{max} \leq 1 \quad (6.34)$$

substituting the allowable centric stress in the first term and the allowable bending stress in the second term we have

$$\frac{F/A}{(\sigma_{All})_{centric}} + \frac{M/I}{(\sigma_{All})_{bending}} y_{max} \leq 1 \quad (6.35)$$

This is known as *the interaction formula*.

When an eccentric load is applied outside of the plane of symmetry, it causes bending about two principal axes, see Fig. 6.17. We then have a centric load  $F$  and two couples  $M_y$  and  $M_z$ . Thus the interaction formula can then be modified as

$$\frac{F/A}{(\sigma_{All})_{centric}} + \frac{|M_z|/I_z}{(\sigma_{All})_{bending}} y_{max} + \frac{|M_y|/I_y}{(\sigma_{All})_{bending}} z_{max} \leq 1 \quad (6.36)$$

## 6.6 Examples, solved and unsolved problems

### Problem 6.1

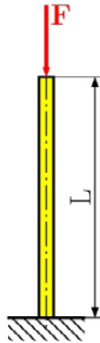


Fig. 6.18

Determine the critical load of the steel bar in Fig. 6.P1. The bar has a circular cross-section area with a diameter  $D = 100\text{mm}$  and has a length of  $L = 5\text{ m}$ . Assume  $E = 200\text{ GPa}$ .

### Solution

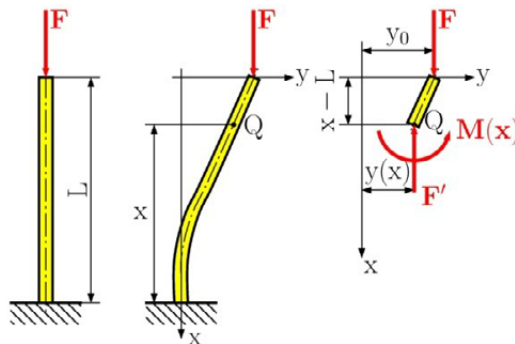


Fig. 6.19

The critical load can be calculated by using the differential equation of the deflection curve, which is

$$y'' = \frac{M(x)}{EI} \quad (a)$$

When the coordinate axes correspond to those in Fig. 6.19 the bending moment at point Q is found from the equilibrium equation

$$\sum M_{iQ} = 0: M(x) - F(y_0 - y(x)) = 0$$

$$M(x) = F(y_0 - y(x)) = F y_0 - F y(x)$$

The normal force at point Q is

$$\sum F_{ix} = 0: -F + F' = 0 \Rightarrow F' = F$$

then inserting the bending moment into Eq. (a), we have

$$y''(x) = \frac{1}{EI} (F y_0 - F y(x)) = \frac{F}{EI} y_0 - \frac{F}{EI} y(x)$$

$$y''(x) + k^2 y(x) = k^2 y_0 \tag{b}$$

where

$$k^2 = \frac{F}{EI} \tag{c}$$

The general solution of Eq. (b) is

$$y(x) = A \cos kx + B \sin kx + y_0 \tag{d}$$

in which  $A$  and  $B$  are constants of integration. These constants are determined from the following boundary conditions

1.  $x = 0, y = 0,$
2.  $x = 0, y' = 0,$
3.  $x = L, y = y_0$

From the first boundary condition, we get

$$0 = A \cos k0 + B \sin k0 + y_0 \Rightarrow A = -y_0$$

Using the next boundary condition, we find the first derivation of the deflection, which is

$$y'(x) = -Ak \sin kx + Bk \cos kx,$$

and set  $x = 0, y' = 0,$  to get

$$0 = -Ak \sin k0 + Bk \cos k0 \Rightarrow B = 0$$

The condition at the upper end of the bar requires that  $y = y_0$  when  $x = L$ , which is satisfied if

$$y_0 \cos kL = 0 \quad (e)$$

Equation (e) requires that either  $y_0 = 0$  or  $\cos kL = 0$ . If  $y_0 = 0$ , there is no deflection of the bar and hence no buckling (Fig. 6.18). If  $\cos kL = 0$ , we must have the relation

$$kL = (2n - 1) \frac{\pi}{2} \quad (f)$$

where  $n = 1, 2, 3, \dots$ . This equation determines values of  $k$  at which a buckled shape can exist. The deflection  $y_0$  remains indeterminate and, for the ideal case, can have any value within the scope of small deflection theory.

The smallest value of  $kL$  which satisfies Eq. (e) is obtained by taking  $n = 1$ . The corresponding value of  $F$  will be the smallest critical load, and we have

$$kL = L \sqrt{\frac{F}{EI}} = \frac{\pi}{2}$$

from which

© 2013 Accenture. All rights reserved.

be > your degree

Bring your talent and passion to a global organization at the forefront of business, technology and innovation. Discover how great you can be.

Visit [accenture.com/bookboon](http://accenture.com/bookboon)

Be greater than.  
consulting | technology | outsourcing

accenture  
High performance. Delivered.

$$F_{cr} = \frac{\pi^2 EI}{4L^2}. \quad (g)$$

and for the given value, we have

$$F_{cr} = \frac{\pi^2 EI}{4L^2} = \frac{\pi^2 E \left( \frac{\pi D^4}{32} \right)}{4L^2} = \frac{\pi^3 E D^4}{4L^2} = \frac{\pi^3 (200 \times 10^9 \text{ Pa}) \times (0.1 \text{ m})^4}{4 \times (5 \text{ m})^2} = 6.2 \text{ MN}.$$

### Problem 6.2

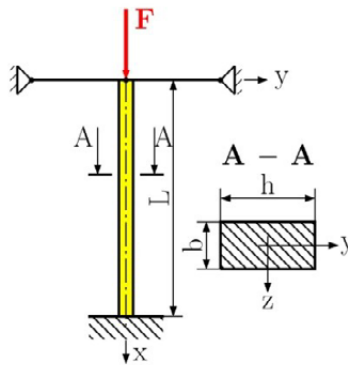


Fig. 6.20

The steel column is fixed at its bottom and is braced at its top by cables so as to prevent movement at the top along the  $y$  axis, Fig. 6.20. If it is assumed to be fixed at its base, determine the largest allowable load  $F$  that can be applied. Use a factor of safety for buckling of  $F.S. = 2.5$ . Assume the parameters:  $E = 200 \text{ GPa}$ ,  $\sigma_y = 250 \text{ MPa}$ ,  $L = 6 \text{ m}$ ,  $b = 50 \text{ mm}$ ,  $h = 100 \text{ mm}$ .

### Solution

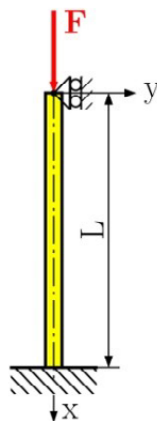


Fig. 6.21

Buckling about the  $y$  and  $z$  axes is shown in Fig. 6.22 and Fig. 6.23, respectively.

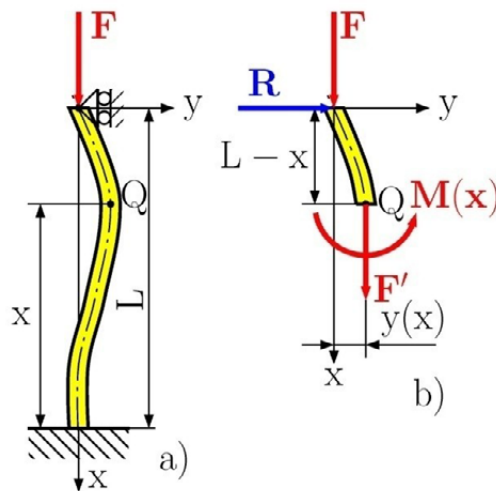
*Buckling in the XY plane.* For the solution, we use Fig. 6.22a and the differential equation of the deflection curve, which is

$$y''(x) = \frac{M(x)}{EI_z} \quad (a)$$

From Fig. 6.22b, using the equilibrium equation, we find the bending moment

$$\sum M_{iQ} = 0: M(x) + F y(x) - R (L - x) = 0$$

$$M(x) = -F y(x) + R (L - x) \quad (b)$$



$$x \in \langle 0, L \rangle$$

Fig. 6.22

and axial force at point Q

$$\sum F_{ix} = 0: -F + F' = 0 \Rightarrow F' = F$$

Inserting Eq. (b) into Eq. (a), we get the differential equation

$$y''(x) = -k^2 y(x) + \frac{R}{EI_z} (L - x),$$

where

$$k^2 = \frac{F}{EI_z} \Rightarrow EI_z = \frac{F}{k^2}.$$

Finally, we have

$$y''(x) + k^2 y(x) = \frac{R}{F} k^2 (L - x). \quad (c)$$

The general solution of Eq. (c) is

$$y(x) = A \cos kx + B \sin kx + \frac{R}{F} (L - x) \quad (d)$$

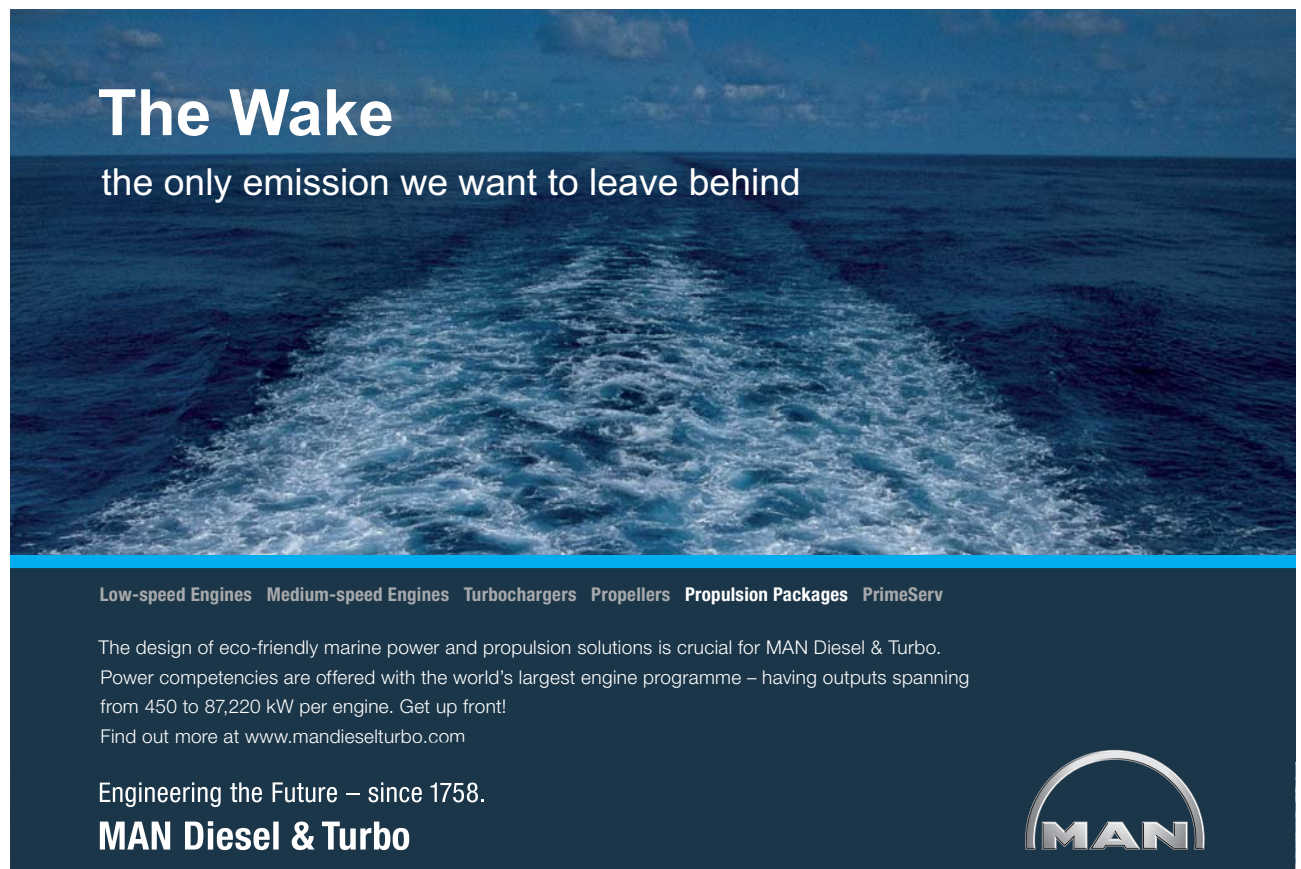
and the first derivative is

$$y'(x) = -Ak \sin kx + Bk \cos kx - \frac{R}{F}.$$

In this equation, we have three unknowns ( $A$ ,  $B$  are integration constants and  $R$  is a reaction), which we find from the following boundary conditions

1.  $x = 0, y = 0,$
2.  $x = 0, y' = 0,$
3.  $x = L, y = 0.$

From boundary condition no. 1, we get




**The Wake**  
the only emission we want to leave behind

Low-speed Engines Medium-speed Engines Turbochargers Propellers Propulsion Packages PrimeServ

The design of eco-friendly marine power and propulsion solutions is crucial for MAN Diesel & Turbo. Power competencies are offered with the world's largest engine programme – having outputs spanning from 450 to 87,220 kW per engine. Get up front! Find out more at [www.mandieselturbo.com](http://www.mandieselturbo.com)

Engineering the Future – since 1758.  
**MAN Diesel & Turbo**



$$0 = A \cos k0 + B \sin k0 + \frac{R}{F}(L-0) \Rightarrow A = -\frac{R}{F}L.$$

From the second condition, we have

$$0 = -Ak \sin k0 + Bk \cos k0 - \frac{R}{F} \Rightarrow B = \frac{R}{kF},$$

and from the last condition, we get

$$0 = A \cos kL + B \sin kL$$

$$\frac{R}{F}L \cos kL = \frac{R}{kF} \sin kL \Rightarrow kL = \tan kL \quad (e)$$

The solution of Eq. (e) is found by numerical methods with the following result

$$kL = 4.493 \Rightarrow k = \frac{4.493}{L},$$

from which

$$F_{cr\ xy} = \frac{\pi^2 EI_z}{(0.7 L)^2}. \quad (f)$$

The moment of inertia of a rectangular cross-section with respect to the z axis is

$$I_z = \frac{1}{12} b h^3 \quad I_z = \frac{1}{12} (50 \text{ mm})(100 \text{ mm})^3 = 4.166 \times 10^6 \text{ mm}^4$$

The value of critical load in the XY plane is

$$F_{cr\ xy} = \frac{\pi^2 (200 \times 10^3 \text{ MPa})(4.166 \times 10^6 \text{ mm}^4)}{(0.7 \times 6000 \text{ mm})^2} \Rightarrow F_{cr\ xy} = 466.18 \text{ kN}.$$

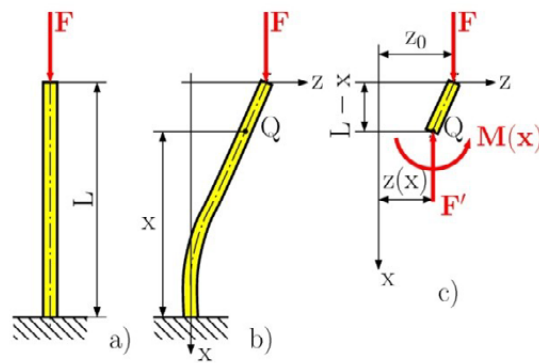


Fig. 6.23

*Buckling in the XZ plane.*

The solution in this plane is the same as in Problem 6.1, where the critical load was solved by

$$F_{\text{cr } xz} = \frac{\pi^2 EI_y}{(2L)^2}.$$

The moment of inertia of a rectangular cross-section with respect to the y axis is

$$I_y = \frac{1}{12} h b^3 \quad I_y = \frac{1}{12} (100 \text{ mm})(50 \text{ mm})^3 = 1.042 \times 10^6 \text{ mm}^4$$

The critical load in the XZ plane is

$$F_{\text{cr } xy} = \frac{\pi^2 (200 \times 10^3 \text{ MPa})(4.166 \times 10^6 \text{ mm}^4)}{(0.7 \times 6000 \text{ mm})^2} \Rightarrow F_{\text{cr } xy} = 466.18 \text{ kN}.$$

By comparison, as the magnitude of  $F$  increases the more the column will buckle within the XY plane.

The allowable load is therefore

$$F_{\text{allow}} = \frac{F_{\text{cr}}}{\text{F.S.}} = \frac{14.28 \text{ kN}}{2.5} = 5.71 \text{ kN}.$$

Since

$$\sigma_{\text{cr}} = \frac{F_{\text{cr}}}{A} = \frac{14.28 \text{ kN}}{5000 \text{ mm}^2} = 2.86 \text{ MPa} < 250 \text{ MPa}$$

Euler's equation can be applied.

Problem 6.3

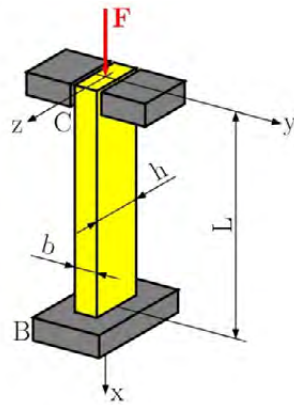


Fig. 6.24

A steel column of length  $L$  and rectangular cross section has a fixed end at  $B$  and supports a centric load at  $C$ . Two smooth, rounded fixed plates restrain the end of the beam (point  $C$ ) from moving in one of the vertical planes of symmetry, but allow it to move in the other plane. (a) Determine the ratio  $h/b$  of the two sides of cross section which correspond to the most efficient design against buckling. (b) Design the most efficient cross section for the column, knowing that  $L = 500 \text{ mm}$ ,  $E = 2.1 \cdot 10^5 \text{ MPa}$ ,  $F = 1000 \text{ N}$ , and that a factor of safety of 3.0 is required.

# SMS from your computer

...Sync'd with your Android phone & number

FREE  
30 days trial!

Go to

BrowserTexting.com

and start texting from your computer!

Click on the ad to read more

**Solution**

*Buckling in the XY plane.* The critical load for this plane is defined by Eq. (6.14), which is

$$F_{\text{cr xy}} = \frac{\pi^2 EI_z}{L_e^2} = \frac{\pi^2 EI_z}{(0.7L)^2}$$

where

$$I_z = \frac{1}{12} hb^3 \quad A = h b$$

and since

$$I_z = A r_z^2 \quad r_z^2 = \frac{I_z}{A} = \frac{\frac{1}{12} h b^3}{h b} = \frac{b^2}{12} \Rightarrow r_z = \frac{b}{\sqrt{12}}.$$

The effective slenderness ratio, Eq. (6.14), of the column with respect to buckling in the xy plane is

$$\lambda_{\text{xy}} = \frac{L_e}{r_z} = \frac{0.7L}{b/\sqrt{12}} = \frac{0.7\sqrt{12}L}{b}. \quad (\text{a})$$

*Buckling in the XZ plane.* The critical load for this plane is defined by Eq. (6.14), which is

$$F_{\text{cr xy}} = \frac{\pi^2 EI_z}{L_e^2} = \frac{\pi^2 EI_z}{(2L)^2}$$

where

$$I_y = \frac{1}{12} b h^3$$

and since

$$I_y = A r_y^2 \quad r_y^2 = \frac{I_y}{A} = \frac{\frac{1}{12} b h^3}{h b} = \frac{h^2}{12} \Rightarrow r_y = \frac{h}{\sqrt{12}}.$$

The effective slenderness ratio, Eq. (6.14), of the column with respect to buckling in the xz plane will be

$$\lambda_{\text{xz}} = \frac{L_e}{r_y} = \frac{2L}{h/\sqrt{12}} = \frac{2\sqrt{12}L}{h}. \quad (\text{b})$$

- a) *The Most Effective Design.* The most effective design is that for which the critical stresses corresponding to the two possible modes of buckling are equal. We note that this will be the case if the two values, obtained above, for the effective slenderness ratio are equal. So we can write

$$\lambda_{xy} = \lambda_{xz}, \quad \frac{0.7\sqrt{12}L}{b} = \frac{2\sqrt{12}L}{h} \Rightarrow \frac{b}{h} = \frac{0.7}{2} = 0.35.$$

- b) *Design for the given data.* Since a F.S. = 3 is required.

$$F_{cr} = (\text{F.S.}) F = (3)(1000 \text{ N}) = 3000 \text{ N}$$

Using  $b = 0.35 h$ , we have  $A = h b = h (0.35 h) = 0.35 h^2$  and

$$\sigma_{cr} = \frac{F_{cr}}{A} = \frac{3000 \text{ N}}{0.35 h^2} \tag{c}$$

Setting  $L = 500 \text{ mm}$  in Eq. (b), we have

$$\lambda_{xz} = \frac{L_e}{r_y} = \frac{2\sqrt{12}L}{h} = \frac{2\sqrt{12}500}{h} = \frac{3464.10}{h}$$

where the critical stress is

$$\sigma_{cr} = \frac{\pi^2 E}{\lambda^2} = \frac{\pi^2 E}{(L_e/r)^2} = \frac{\pi^2 (2.1 \times 10^5 \text{ MPa})}{(3464.10/h)^2} \tag{d}$$

comparing Eq. (c) and Eq. (d), we write

$$\frac{3000 \text{ N}}{0.35 h^2} = \frac{\delta^2 (2.1 \times 10^5 \text{ MPa})}{(3464.10/h)^2}$$

$$\frac{3000 \text{ N}}{0.35} \frac{(3464.10)^2}{\delta^2 (2.1 \times 10^5 \text{ MPa})} = h^4$$

and have

$$h = 14.93 \text{ mm}, \quad b = 0.35 h = 0.35 \times 14.93 \text{ mm} = 5.22 \text{ mm}$$

## Problem 6.4

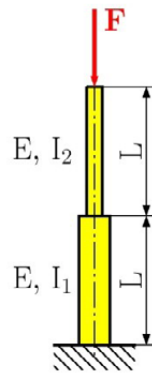


Fig. 6.25

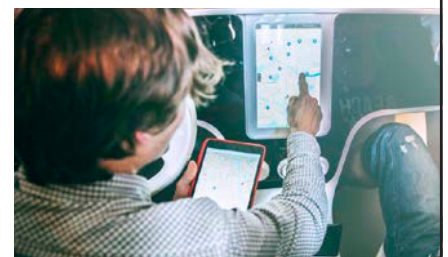
The column in Fig. 6.25 consists of two different cross-section areas and has a length of  $L = 2$  m. The relationship between the moment of inertia of the first and second cross-section area is  $I_1 = 4I_2$ . If the

bottom end is a fixed support while the top is free, determine the largest axial load which can be supported. Use  $E = 210$  GPa,  $I_2 = 0.15 \cdot 10^6$  mm<sup>4</sup>.

YOUR WORK AT TOMTOM WILL  
BE TOUCHED BY MILLIONS.  
**AROUND THE WORLD. EVERYDAY.**

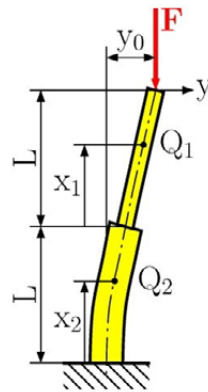
Join us now on [www.TomTom.jobs](http://www.TomTom.jobs)

follow us on **LinkedIn**



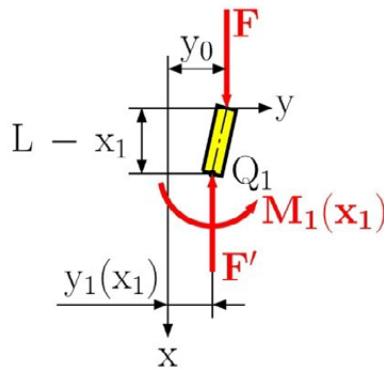
**#ACHIEVEMORE**

**TOMTOM** 

**Solution****Fig. 6.26**

We divide this problem into two parts for its solution, because we have two parts with different cross-section. Deflection of the column after an applied critical load is shown in Fig. 6.26.

*Solution of the first part.*  $x_1 \in \langle 0, L \rangle$

**Fig. 6.27**

From the equilibrium equation for the first part in Fig. 6.27, we have

$$\sum M_{iQ_1} = 0: M_1(x_1) - F(y_0 - y_1(x_1)) = 0$$

$$M_1(x_1) = F(y_0 - y_1(x_1)) = F y_0 - F y_1(x_1)$$

$$\sum F_{ix_1} = 0: -F + F' = 0 \Rightarrow F' = F$$

The next step of the solution is to insert the bending moment into the differential equation of deflection in the form

$$y_1''(x_1) = \frac{M_1(x_1)}{EI_1},$$

and we have

$$y_1''(x_1) = \frac{1}{EI_1} (F y_0 - F y_1(x_1)) = \frac{F}{EI_1} y_0 - \frac{F}{EI_1} y_1(x_1)$$

$$y_1''(x_1) = k_1^2 y_0 - k_1^2 y_1(x_1)$$

$$y_1''(x_1) + k_1^2 y_1(x_1) = k_1^2 y_0 \quad (a)$$

where

$$k_1^2 = \frac{F}{EI_1}.$$

The solution of Eq. (a) is as follows

$$y_1(x_1) = A \cos k_1 x_1 + B \sin k_1 x_1 + y_0 \quad (b)$$

where  $A$  and  $B$  are unknown integration constants and  $y_0$  is the unknown deflection of the column's free end.

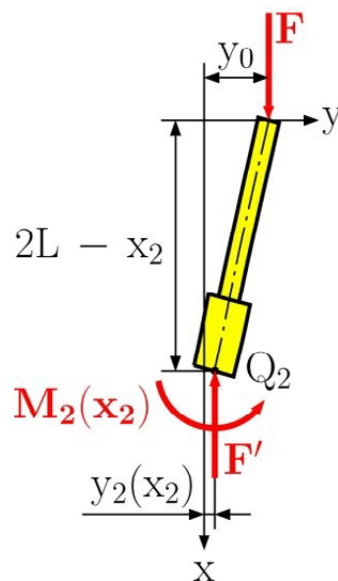


Fig. 6.28

*Solution of the second part.*  $x_2 \in \langle 0, L \rangle$

The second part is shown in Fig. 6.28. The Unknown internal load is found from the equilibrium equations, which are

$$\sum M_{iQ_2} = 0: M_2(x_2) - F(y_0 - y_2(x_2)) = 0$$

$$M_2(x_2) = F(y_0 - y_2(x_2)) = F y_0 - F y_2(x_2)$$

$$\sum F_{ix_2} = 0: -F + F' = 0 \Rightarrow F' = F$$

Using the bending moment  $M_2(x_2)$  and differential equation of beam deflection in the form

$$y_2''(x_2) = \frac{M_2(x_2)}{EI_2},$$

from which

$$y_2''(x_2) + k_2^2 y_2(x_2) = k_2^2 y_0 \quad (c)$$

where

$$k_2^2 = \frac{F}{EI_2}$$

The general solution of Eq. (c) is

$$y_2(x_2) = C \cos k_2 x_2 + D \sin k_2 x_2 + y_0 \quad (d)$$

where  $C$  and  $D$  are unknown integration constants, which we find from the following boundary conditions:

1.  $x_2 = 0, y_2 = 0,$
2.  $x_2 = 0, y_2' = 0,$
3.  $x_1 = 0, x_2 = L, y_1' = y_2',$
4.  $x_1 = 0, x_2 = L, y_1 = y_2,$
5.  $x_1 = L, y_1 = 0,$

Using the first condition, we get

$$0 = C \cos k_2 0 + D \sin k_2 0 + y_0 \Rightarrow C = -y_0.$$

Derivation of Eq. (d) is

$$y_2'(x_2) = -Ck_2 \sin k_2 x_2 + Dk_2 \cos k_2 x_2,$$

Using the second condition, we have

$$0 = -Ck \sin k_2 0 + Dk \cos k_2 0 \Rightarrow D = 0 \text{ for } k_2 \neq 0$$

In the same way, we find the derivation of deflection for the first part, which is

$$y'_1(x_1) = -Ak_1 \sin k_1 x_1 + Bk_1 \cos k_1 x_1.$$

and for

$$x_1 = 0, x_2 = L, y'_1 = y'_2,$$

we get

$$-Ak_1 \sin k_1 0 + Bk_1 \cos k_1 0 = -Ck_2 \sin k_2 L + Dk_2 \cos k_2 L$$

$$Bk_1 = -Ck_2 \sin k_2 L \Rightarrow B = y_0 \frac{k_2}{k_1} \sin k_2 L$$

Using condition no. 4, we have

$$A \cos k_1 0 + B \sin k_1 0 + y_0 = C \cos k_2 L + D \sin k_2 L + y_0,$$

**Brain power**

By 2020, wind could provide one-tenth of our planet's electricity needs. Already today, SKF's innovative know-how is crucial to running a large proportion of the world's wind turbines.

Up to 25 % of the generating costs relate to maintenance. These can be reduced dramatically thanks to our systems for on-line condition monitoring and automatic lubrication. We help make it more economical to create cleaner, cheaper energy out of thin air.

By sharing our experience, expertise, and creativity, industries can boost performance beyond expectations. Therefore we need the best employees who can meet this challenge!

The Power of Knowledge Engineering

Plug into The Power of Knowledge Engineering.  
Visit us at [www.skf.com/knowledge](http://www.skf.com/knowledge)

**SKF**

from which

$$A = -y_0 \cos k_2 L.$$

and from the last condition, we get

$$\frac{k_1}{k_2} = \tan k_1 L \tan k_2 L. \quad (e)$$

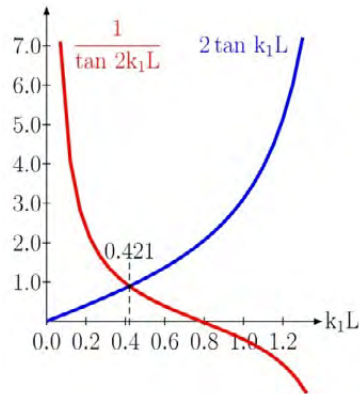


Fig. 6.29

Since  $I_1 = 4 I_2$  is required, from which we have a ratio between  $k_1$  and  $k_2$

$$\frac{k_1^2}{k_2^2} = \frac{\frac{F}{EI_1}}{\frac{F}{EI_2}} = \frac{I_2}{I_1} \Rightarrow k_2 = k_1 \sqrt{\frac{I_1}{I_2}} = k_1 \sqrt{\frac{4I_2}{I_2}} = 2k_1$$

Inserting this result into Eq. (e), we get

$$\frac{1}{2} = \tan k_1 L \tan 2k_1 L \Rightarrow 2 \tan k_1 L = \frac{1}{\tan 2k_1 L}. \quad (f)$$

From the numerical calculation of Eq. (f) or from the graphical solution shown in Fig. 6.29, we have

$$k_1 L = 0.421,$$

which we compare with equation

$$k_1 L = \alpha \pi$$

from which

$$\alpha = 0.134$$

This result, we plug into the general equation for the solution of the critical load (Eq. (6.14)), we get

$$F_{cr} = \frac{\pi^2 \alpha^2 EI_1}{L^2} = \frac{0.177 EI_1}{L^2}.$$

For the given parameters, the critical load is

$$F_{cr} = \frac{0.177 EI_1}{L^2} = \frac{0.177(210 \times 10^3 \text{ MPa})(4 \times 0.15 \times 10^6 \text{ mm}^4)}{(2000 \text{ mm})^2}$$

$$F_{cr} = 5.58 \text{ kN}$$

### Problem 6.5

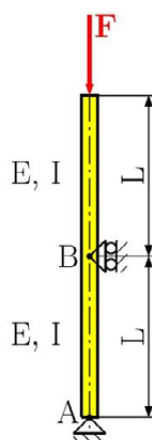
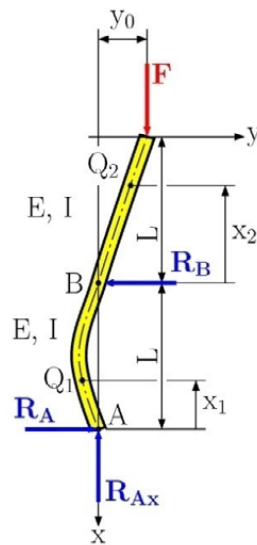


Fig. 6.30

Determine the critical load of an aluminium tube shown in Fig. 6.30, which has a length  $L = 2.5$  m and an outer diameter of 100 mm and 16 mm wall thickness. Assume  $E = 70$  GPa.

**Solution****Fig. 6.31**

The first step of the solution is to determine the support reactions for the deformed column in Fig. 6.31. From the following equilibrium equation, we find the reactions in the support.

$$\sum F_{ix} = 0: -F + R_{Ax} = 0 \Rightarrow R_{Ax} = F$$

**> Apply now**

REDEFINE YOUR FUTURE  
**AXA GLOBAL GRADUATE  
PROGRAM 2015**

redefining / standards 

agence.cdg © Photonistop

$$\sum M_{iA} = 0: F y_0 - R_B L = 0 \Rightarrow R_B = \frac{F y_0}{L}$$

$$\sum M_{iB} = 0: F y_0 - R_A L = 0 \Rightarrow R_A = \frac{F y_0}{L}$$

The problem consists of a two part solution.

The solution of the first part is in Fig. 6.32 for  $x_1$  from 0 to  $L$ . At position  $x_1$  we find the bending moment  $M_1$  and axial load  $F'$  from the following equilibrium equations

$$\sum M_{iQ_1} = 0: M_1(x_1) - R_{Ax}(-y_1(x_1)) - R_A x_1 = 0$$

$$M_1(x_1) = -R_{Ax} y_1(x_1) + R_A x_1$$

$$M_1(x_1) = -F y_1(x_1) + \frac{F y_0}{L} x_1 \tag{a}$$

$$\sum F_{ix_1} = 0: -F + F' = 0 \Rightarrow F' = F$$

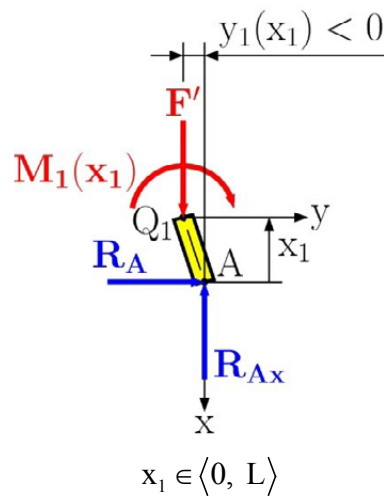


Fig. 6.32

We insert the result of Eq. (a) into the differential equation

$$y_1'' = \frac{M_1(x_1)}{EI},$$

we then have

$$y''(x) + k^2 y_1(x_1) = k^2 \frac{y_0}{L} x_1, \quad (\text{b})$$

where

$$k^2 = \frac{F}{EI}.$$

Solution of the differential equation, Eq. (b), is

$$y_1(x_1) = A \cos kx_1 + B \sin kx_1 + \frac{y_0}{L} x_1 \quad (\text{c})$$

and the first derivation of Eq. (c) is

$$y'_1(x_1) = -Ak \sin kx_1 + Bk \cos kx_1 + \frac{y_0}{L}.$$

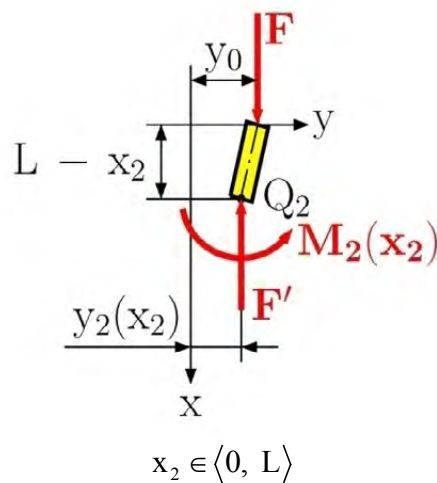


Fig. 6.33

The solution of the second part is in Fig. 6.33 for  $x_2$  from 0 to  $L$ . At position  $x_2$ , we find the bending moment  $M_2$  and axial load  $F'$  from the following equilibrium equations

$$\sum M_{iQ_2} = 0: M_2(x_2) - F(y_0 - y_2(x_2)) = 0$$

$$M_2(x_2) = F(y_0 - y_2(x_2)) = F y_0 - F y_2(x_2) \quad (\text{d})$$

$$\sum F_{ix_2} = 0: -F + F' = 0 \Rightarrow F' = F$$

We substitute the result in Eq. (d) into the differential equation

$$y_2''(x_2) = \frac{M_2(x_2)}{EI},$$

and have

$$y_2''(x_2) + k^2 y_2(x_2) = k^2 y_0. \quad (e)$$

The solution of the differential equation, Eq. (e), is

$$y_2(x_2) = C \cos kx_2 + D \sin kx_2 + y_0 \quad (f)$$

and the first derivation of Eq. (f) is

$$y_2'(x_2) = -Ck \sin kx_2 + Dk \cos kx_2.$$

The unknown integration constants A, B, C, D and the unknown deflection  $y_0$  are found from the boundary conditions:

$$1. \quad x = 0 \quad x = 0$$

LIGS University

based in Hawaii, USA

is currently enrolling in the  
Interactive Online **BBA, MBA, MSc,**  
**DBA and PhD** programs:

- ▶ enroll **by October 31st, 2014** and
- ▶ **save up to 11%** on the tuition!
- ▶ pay in 10 installments / 2 years
- ▶ Interactive **Online** education
- ▶ visit [www.ligsuniversity.com](http://www.ligsuniversity.com) to find out more!

Note: LIGS University is not accredited by any nationally recognized accrediting agency listed by the US Secretary of Education. More info [here](http://www.ligsuniversity.com).



2.  $x_2 = 0, y_2 = 0,$
3.  $x_1 = L, x_2 = 0, y_1 = 0,$
4.  $x_1 = L, x_2 = 0, y'_1 = y'_2,$
5.  $x_2 = L, y_2 = 0.$

From the first boundary condition we have

$$0 = A \cos k0 + B \sin k0 + \frac{y_0}{L} 0 \Rightarrow A = 0.$$

where from the second boundary condition we get

$$0 = C \cos k0 + D \sin k0 + y_0 \Rightarrow C = -y_0.$$

and from the third condition, we have

$$0 = B \sin kL + \frac{y_0}{L} L \Rightarrow B = -\frac{y_0}{\sin kL}.$$

From condition no. 4, we get

$$-Ak \sin kL + Bk \cos kL + \frac{y_0}{L} = -Ck \sin k0 + Dk \cos k0$$

from which

$$D = \frac{y_0}{kL} - y_0 \frac{\cos kL}{\sin kL} = \frac{y_0}{kL} - y_0 \cotan kL.$$

and finally from the last condition, we have

$$2 \cos kL = \frac{1}{kL} \sin kL \Rightarrow 2kL = \tan kL \quad (g)$$

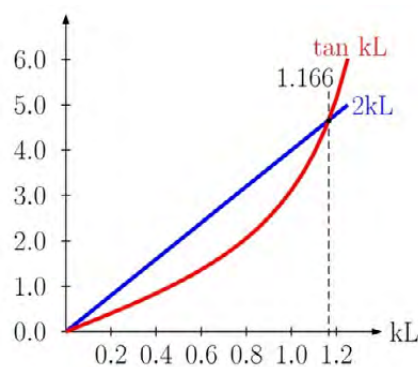


Fig. 6.34

The numerical solution of Eq. (g) or from the graphical solution in Fig. 6.34, we get

$$kL = 1.166$$

from which

$$F_{cr} = \frac{1.35EI}{L^2} \quad (f)$$

For the given parameters, we have

$$I = \frac{\pi D_{out}^4}{64} - \frac{\pi D_{in}^4}{64} = \frac{\pi}{64} \left[ (100\text{mm})^4 - (68\text{mm})^4 \right]$$

and the critical load is

$$F_{cr} = \frac{1.35EI}{L^2} = \frac{1.35 (70 \times 10^3 \text{MPa}) (3.86 \times 10^6 \text{mm}^4)}{(2500 \text{mm})^2}$$

$$F_{cr} = 58.4 \text{ kN}$$

### Problem 6.6

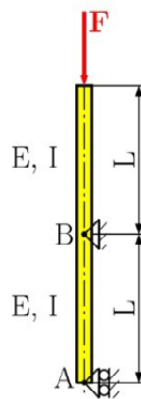
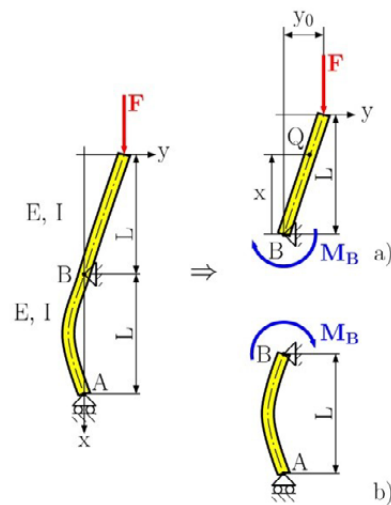


Fig. 6.35

Determine the critical load of the steel tube in Fig. 6.35, consider the following parameters:  $L = 4 \text{ m}$ ,  $I = 7.794 \times 10^6 \text{ mm}^4$ ,  $E = 210 \text{ GPa}$ .

**Solution****Fig. 6.36**

$$x \in \langle 0, L \rangle$$

In this problem, we divide into two parts, the buckling is only in the part in Fig. 6.36a, the second part in Fig. 6.36b is without buckling, because in point B there is a pin support.

## TURN TO THE EXPERTS FOR SUBSCRIBE CONSULTANCY

Subscribe is one of the leading companies in Europe when it comes to innovation and business development within subscription businesses.

We innovate new subscription business models or improve existing ones. We do business reviews of existing subscription businesses and we develop acquisition and retention strategies.

Learn more at [linkedin.com/company/subscribe](https://www.linkedin.com/company/subscribe) or contact  
Managing Director Morten Suhr Hansen at [mha@subscribe.dk](mailto:mha@subscribe.dk)

**SUBSCRIBE** - to the future

From the moment at point B, we get

$$\sum M_{iB} = 0: M_B + F y_0 = 0 \Rightarrow M_B = -F y_0$$

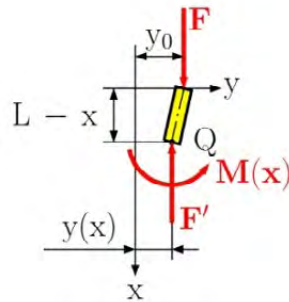


Fig. 6.37

Solution for the buckling part of Fig. 6.37, we find the internal load at point Q, which are the following

$$\sum M_{iQ} = 0: M(x) - F(y_0 - y(x)) = 0$$

$$M(x) = F(y_0 - y(x)) = F y_0 - F y(x) \quad (a)$$

$$\sum F_{ix} = 0: -F + F' = 0 \Rightarrow F' = F$$

For the calculation of the critical load, we use the differential equation of the deflection curved, which is

$$y''(x) = \frac{M(x)}{EI}. \quad (b)$$

After putting Eq. (a) into Eq. (b), we have

$$y''(x) + k^2 y(x) = k^2 y_0 \quad (c)$$

where

$$k^2 = \frac{F}{EI}.$$

the solution of Eq. (c) is

$$y(x) = A \cos kx + B \sin kx + y_0 \quad (d)$$

and its first derivation is

$$y'(x) = -Ak \sin kx + Bk \cos kx.$$

The unknowns integration constant A and B, are found from the boundary conditions

1.  $x = 0, y = 0,$
2.  $x = 0, y' = \varphi,$
3.  $x = L, y = y_0$

From the first condition, we have

$$0 = A \cos k0 + B \sin k0 + y_0 \Rightarrow A = -y_0.$$

where from the third condition, we get

$$0 = -y_0 \cos kL + B \sin kL \Rightarrow B = y_0 \frac{\cos kL}{\sin kL}.$$

In the second condition, we have an unknown slope  $j$  of the deflection curve at point B, which we find from the second part in Fig. 6.38a. Using Castigliano's theorem for the solution, the bending moment  $M(x)$  at point Q in Fig. 6.38b is

$$\sum M_{iQ} = 0: M(x) + M_B - R_B x = 0 \Rightarrow M(x) = R_B x - M_B$$

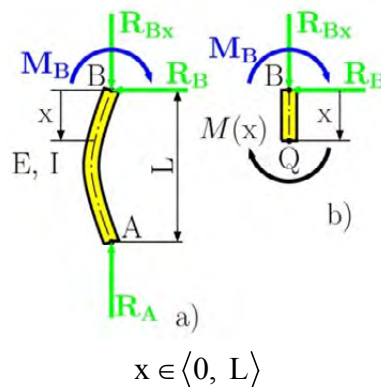


Fig. 6.38

In this equation, the reaction  $R_B$  is unknown, which we find from the equilibrium at point A in Fig. 6.19a,

$$\sum M_{iA} = 0: -M_B + R_B L = 0 \Rightarrow R_B = \frac{M_B}{L}$$

The strain energy in bending, from the Appendix, is defined as

$$U = \int_0^L \frac{M^2}{2EI} dx \quad (\text{A.31})$$

and Castigliano's theorem is

$$\varphi = \frac{\partial U}{\partial M_B} = \frac{\partial}{\partial M_B} \left( \int_0^L \frac{M(x)^2}{2EI} dx \right) = \frac{1}{EI} \int_0^L M(x) \frac{\partial M(x)}{\partial M_B} dx$$

After the solution, we have

$$\varphi = \frac{1}{EI} \int_0^L M_B \left( \frac{x}{L} - 1 \right) \left( \frac{x}{L} - 1 \right) dx = \frac{M_B L}{3EI}$$

$$\varphi = -\frac{F y_0 L}{3EI} = -k^2 \frac{y_0 L}{3} \quad (\text{e})$$

"I studied English for 16 years but...  
...I finally learned to speak it in just six lessons"

Jane, Chinese architect

ENGLISH OUT THERE

Click to hear me talking before and after my unique course download

Now, we insert the result from Eq. (e) to the second boundary condition, and get

$$kL = -3 \frac{\cos kL}{\sin kL} = -3 \cotan kL \quad (f)$$

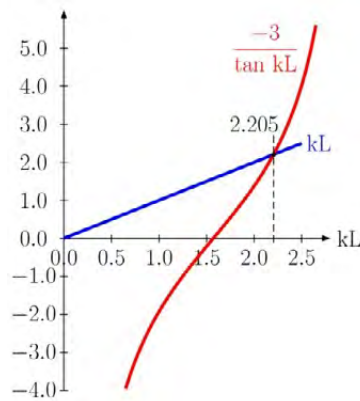


Fig. 6.39

After the numerical solution, or from the graphical solution in Fig. 6.39, we get

$$kL = 2.205 \Rightarrow \alpha = \frac{kL}{\pi} = 0.702$$

We insert this result into the general equation for the solution of the critical load (Eq. (6.14)) and get

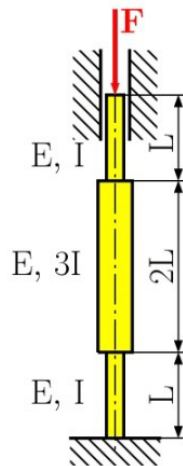
$$F_{cr} = \frac{\pi^2 \alpha^2 EI}{L^2} = \frac{4.862 EI}{L^2}$$

For the given parameters, the critical load is

$$F_{cr} = \frac{4.862 EI}{L^2} = \frac{4.862 (210 \times 10^3 \text{ MPa})(7.794 \times 10^6 \text{ mm}^4)}{(4000 \text{ mm})^2}$$

$$F_{cr} = 497.4 \text{ kN}$$

**Problem 6.7**



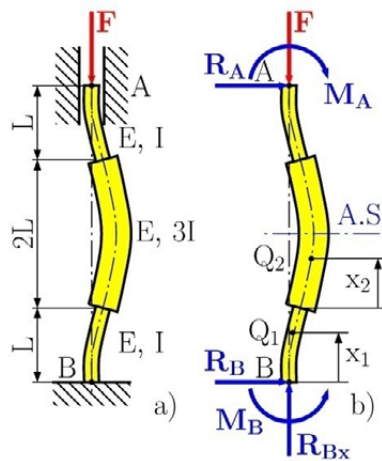
**Fig. 6.40**

Determine the critical load for the column in Fig. 6.40.

L, E and I are given.

**Solution**

$$x_1 \in \langle 0, L \rangle$$



**Fig. 6.41**

First we solve for the reaction in the deformed column, see Fig. 6.41a. From the free body diagram and the following equilibrium equations, we find the reactions at the support, which are

$$\sum F_{ix} = 0: -F + R_{Bx} = 0 \Rightarrow R_{Bx} = F,$$

$$\sum F_{iy} = 0: R_A + R_B = 0 \Rightarrow R_A = R_B,$$

This problem is symmetric, from this condition we denote  $M$  as the moment in the supports A and B, that is

$$M_B = M_A = M$$

From the equilibrium of the moments at point B, we get

$$\sum M_{iB} = 0: M_B - M_A - R_A 4L = 0 \Rightarrow R_A = 0$$

The solution is divide into two parts, which is show in Fig. 6.41b, because we are using an axis of symmetry.

$$x_1 \in \langle 0, L \rangle$$

**wethrive.net**

**How to retain your top staff**

**FIND OUT NOW FOR FREE**

**DO YOU WANT TO KNOW:**

- What your staff really want?
- The top issues troubling them?
- How to make staff assessments work for you & them, painlessly?

**Get your free trial**

Because happy staff get more done

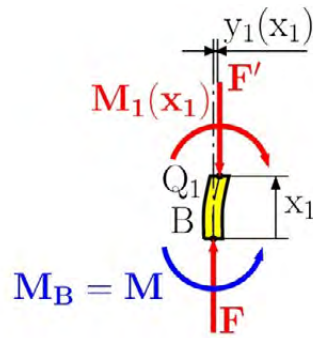


Fig. 6.42

*Solution of the first part in Fig. 6.42.*

At location  $x_1$  in point  $Q_1$ , we find the bending moment  $M_1(x_1)$  and axial force  $F'$  from the following equilibrium equation

$$\sum M_{iQ_1} = 0: M_1(x_1) + Fy_1(x_1) - M = 0$$

$$M_1(x_1) = -F y_1(x_1) + M \quad (\text{a})$$

$$\sum F_{ix_1} = 0: -F + F' = 0 \Rightarrow F' = F$$

Inserting Eq. (a) into the differential equation of the deflection curve

$$y_1'' = \frac{M_1(x_1)}{EI_1},$$

from which

$$x_2 \in \langle 0, L \rangle$$

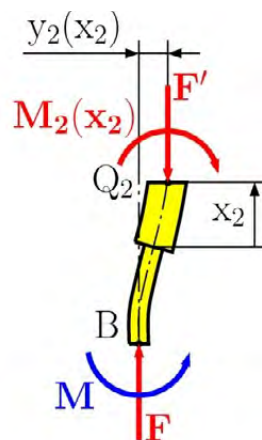


Fig. 6.43

$$y''(x) + k_1^2 y_1(x_1) = k_1^2 \frac{M}{F}, \quad (\text{b})$$

where

$$k_1^2 = \frac{F}{EI_1} = \frac{F}{EI}.$$

The solution of Eq. (b) is

$$y_1(x_1) = A \cos k_1 x_1 + B \sin k_1 x_1 + \frac{M}{F} \quad (\text{c})$$

and the first derivation is

$$y'_1(x_1) = -A k_1 \sin k_1 x_1 + B k_1 \cos k_1 x_1.$$

*Solution of second part in Fig. 6.43.*

The bending moment  $M_2(x_2)$  and axial force  $F'$  we obtain from the following equilibrium equation

$$\sum M_{iQ_2} = 0: M_2(x_2) + F y_2(x_2) - M = 0$$

$$M_2(x_2) = -F y_2(x_2) + M \quad (\text{d})$$

$$\sum F_{ix_2} = 0: -F + F' = 0 \Rightarrow F' = F$$

inserting Eq. (d) into the differential equation of the deflection curve

$$y_2''(x_2) = \frac{M_2(x_2)}{EI_2}$$

from which

$$y_2''(x_2) + k_2^2 y_2(x_2) = k_2^2 \frac{M}{F} \quad (\text{e})$$

where

$$k_2^2 = \frac{F}{EI_2} = \frac{F}{3EI}.$$

The solution of Eq. (b) is

$$y_2(x_2) = C \cos k_2 x_2 + D \sin k_2 x_2 + \frac{M}{F} \quad (f)$$

and its first derivative is

$$y_2'(x_2) = -Ck_2 \sin k_2 x_2 + Dk_2 \cos k_2 x_2$$

To find the unknown integration constants A, B, C, D and the moment at the support M, we use the following boundary conditions

1.  $x_1 = 0, y_1 = 0$
2.  $x_2 = L, y_2' = 0$
3.  $x_1 = L, x_2 = 0, y_1 = y_2$
4.  $x_1 = L, x_2 = 0, y_1' = y_2'$
5.  $x_1 = 0, y_1' = 0$

After using all boundary conditions, we have the following results:

$$1. \quad 0 = A \cos k_1 0 + B \sin k_1 0 + \frac{M}{E} \Rightarrow A = -\frac{M}{E}$$

**gaiteye**  
Challenge the way we run

**EXPERIENCE THE POWER OF FULL ENGAGEMENT...**

**RUN FASTER.  
RUN LONGER..  
RUN EASIER...**

**READ MORE & PRE-ORDER TODAY  
WWW.GAITEYE.COM**

$$5. \quad 0 = -Ak_1 \sin k_1 0 + Bk_1 \cos k_1 0 \Rightarrow B = 0$$

$$2. \quad 0 = -Ck_2 \sin k_2 L + Dk_2 \cos k_2 L$$

$$D = C \frac{\sin k_2 L}{\cos k_2 L} = C \tan k_2 L$$

$$3. \quad A \cos k_1 L + B \sin k_1 L + \frac{M}{F} = C \cos k_2 0 + D \sin k_2 0 + \frac{M}{F}$$

$$C = A \cos k_1 L = -\frac{M}{F} \cos k_1 L$$

$$4. \quad -Ak_1 \sin k_1 L + Bk_1 \cos k_1 L = -Ck_2 \sin k_2 0 + Dk_2 \cos k_2 0$$

$$\frac{k_1}{k_2} \tan k_1 L = -\tan k_2 L \tag{g}$$

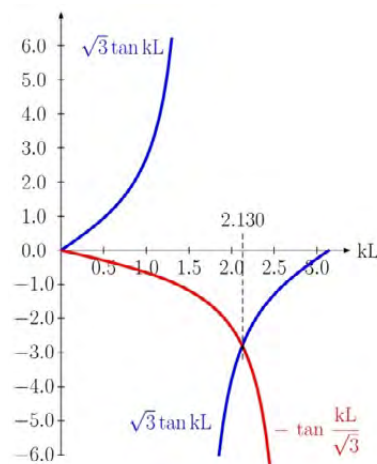


Fig. 6.44

Setting a ratio between  $k_1$  and  $k_2$  in the form

$$\frac{k_1^2}{k_2^2} = \frac{\frac{F}{EI_1}}{\frac{F}{EI_2}} = \frac{I_2}{I_1} \Rightarrow k_2 = k_1 \sqrt{\frac{I_1}{I_2}} = k_1 \sqrt{\frac{I}{3I}} = \frac{k_1}{\sqrt{3}}$$

And inserting into Eq. (g) we get

$$\sqrt{3} \tan k_1 L = -\tan \frac{k_1}{\sqrt{3}} L \tag{f}$$

We solve Eq. (f) by the numerical method or the graphical method shown in Fig. 6.44, the result is

$$k_1 L = \alpha \pi = 2.13 \Rightarrow \alpha = \frac{k_1 L}{\pi} = 0.678$$

Critical load is

$$F_{cr} = \frac{\pi^2 \alpha^2 EI}{L^2} = \frac{4.54 EI}{L^2}.$$

### Unsolved problems

#### Problem 6.8

Determine the critical load for the column in Fig. 6.45.  $L = 5 \text{ m}$ ,  $I = 3.457 \times 10^6 \text{ mm}^4$ ,  $E = 200 \text{ GPa}$  is given.

$$[F_{cr} = 39.3 \text{ kN}]$$

#### Problem 6.9

Determine the critical load for an aluminum column shown in Fig. 6.46.  $L = 1.5 \text{ m}$ ,  $I = 5.325 \times 10^6 \text{ mm}^4$ ,  $E = 70 \text{ GPa}$  is given.

$$[F_{cr} = 134.6 \text{ kN}]$$

#### Problem 6.10

Determine the critical load for a brass column shown in Fig. 6.47.  $L = 2 \text{ m}$ ,  $I = 9.436 \times 10^6 \text{ mm}^4$ ,  $E = 120 \text{ GPa}$  is given.

$$[F_{cr} = 244.4 \text{ kN}]$$

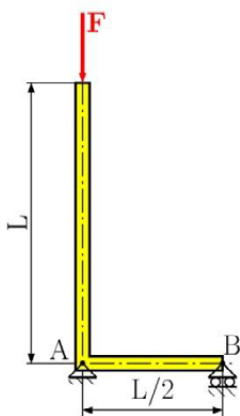


Fig. 6.45

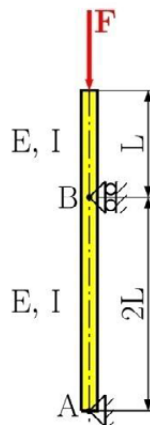


Fig. 6.46

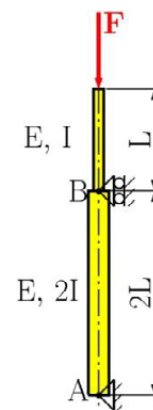


Fig. 6.47

**Problem 6.11**

Determine the critical load for a steel column shown in Fig. 6.48.  $L = 1.5$  m,  $I = 4.91 \times 10^6$  mm<sup>4</sup>,  $E = 210$  GPa is given.

$$[F_{cr} = 604.7 \text{ kN}]$$

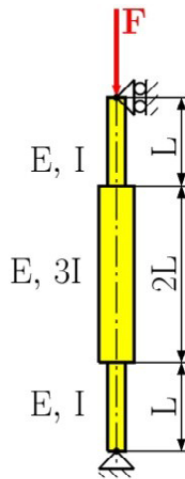


Fig. 6.48

This e-book  
is made with  
**SetaPDF**



PDF components for PHP developers

[www.setasign.com](http://www.setasign.com)

# Appendix

## A.1 Centroid and first moment of areas

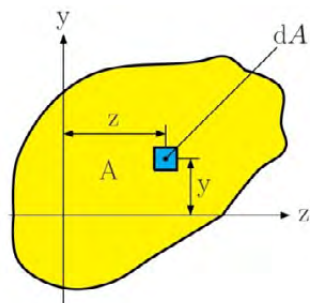


Fig. A.1

Consider an area  $A$  located in the  $zy$  plane (Fig. A.1). The first moment of area with respect to the  $z$  axis is defined by the integral

$$Q_z = \int_A y \, dA \quad (\text{A.1})$$

Similarly, the first moment of area  $A$  with respect to the  $y$  axis is

$$Q_y = \int_A z \, dA \quad (\text{A.2})$$

If we use SI units are used, the first moment of  $Q_z$  and  $Q_y$  are expressed in  $\text{m}^3$  or  $\text{mm}^3$ .

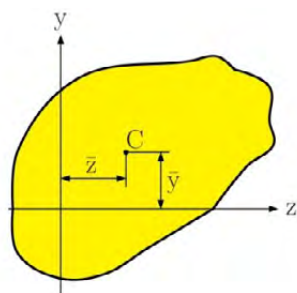


Fig. A.2

The centroid of the area  $A$  is defined at point  $C$  of coordinates  $\bar{y}$  and  $\bar{z}$  (Fig. A.2), which satisfies the relation

$$\bar{y} = \frac{\int_A y \, dA}{A}$$

$$\bar{z} = \frac{\int z \, dA}{A} \tag{A.3}$$

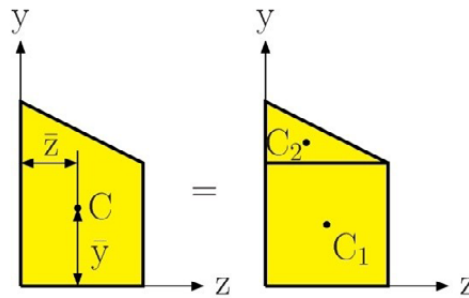


Fig. A.3

When an area possesses an axis of symmetry, the first moment of the area with respect to that axis is zero.

Considering an area  $A$ , such as the trapezoidal area shown in Fig. A.3, we may divide the area into simple geometric shapes. The solution of the first moment  $Q_z$  of the area with respect to the  $z$  axis can be divided into components  $A_1, A_2$ , and we can write

$$Q_z = \int_A y \, dA = \int_{A_1} y \, dA + \int_{A_2} y \, dA = \sum \bar{y}_i A_i \tag{A.4}$$

Solving the centroid for composite area, we write

$$\bar{y} = \frac{\sum A_i \bar{y}_i}{\sum A_i} \qquad \bar{z} = \frac{\sum A_i \bar{z}_i}{\sum A_i} \tag{A.5}$$

**Example A.01**

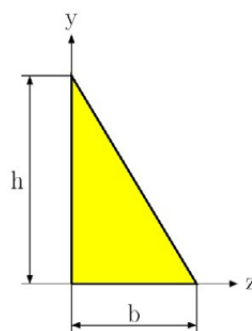
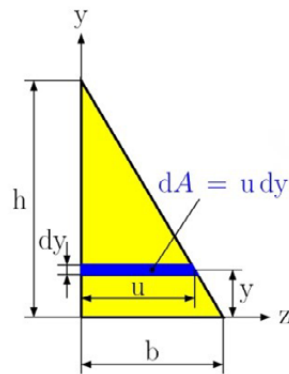


Fig. A.4

For the triangular area in Fig. A.4, determine (a) the first moment  $Q_z$  of the area with respect to the  $z$  axis, (b) the  $\bar{y}$  ordinate of the centroid of the area.

**Solution****(a) First moment  $Q_z$** **Fig. A.5**

We selected an element area in Fig. A.5 with a horizontal length  $u$  and thickness  $dy$ . From the similarity in triangles, we have

$$\frac{u}{b} = \frac{h-y}{h} \quad u = b \frac{h-y}{h}$$



Discover the truth at [www.deloitte.ca/careers](http://www.deloitte.ca/careers)

**Deloitte.**

© Deloitte & Touche LLP and affiliated entities.

and

$$dA = u \, dy = b \frac{h-y}{h} \, dy$$

using Eq. (A.1) the first moment is

$$Q_z = \int_A y \, dA = \int_0^h y b \frac{h-y}{h} \, dy = \frac{b}{h} \int_0^h (hy - y^2) \, dy$$

$$Q_z = \frac{b}{h} \left[ h \frac{y^2}{2} - \frac{y^3}{3} \right] = \frac{1}{6} bh^2$$

### (b) Ordinate of the centroid

Recalling the first Eq. (A.4) and observing that  $A = \frac{1}{2}bh$ , we get

$$Q_z = A\bar{y} \Rightarrow \frac{1}{6}bh^2 = \frac{1}{2}bh^2\bar{y} \Rightarrow \bar{y} = \frac{1}{3}h$$

## A.2 Second moment, moment of areas

Consider again an area  $A$  located in the  $zy$  plane (Fig. A.1) and the element of area  $dA$  of coordinate  $y$  and  $z$ . The *second moment*, or *moment of inertia*, of area  $A$  with respect to the  $z$ -axis is defined as

$$I_z = \int_A y^2 \, dA \tag{A.6}$$

### Example A.02

Locate the centroid  $C$  of the area  $A$  shown in Fig. A.6

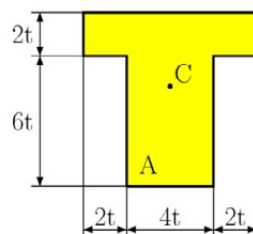
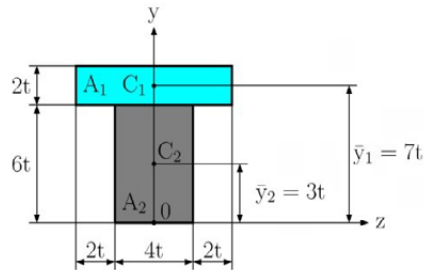


Fig. A.6

**Solution**

Selecting the coordinate system shown in Fig. A.7, we note that centroid C must be located on the y axis, since this axis is the axis of symmetry than  $\bar{z} = 0$ .

**Fig. A.7**

Dividing A into its component parts  $A_1$  and  $A_2$ , determine the  $\bar{y}$  ordinate of the centroid, using Eq. (A.5)

$$\bar{y} = \frac{\sum_i A_i \bar{y}_i}{\sum_i A_i} = \frac{\sum_{i=1}^2 A_i \bar{y}_i}{\sum_{i=1}^2 A_i} = \frac{A_1 \bar{y}_1 + A_2 \bar{y}_2}{A_1 + A_2}$$

$$\bar{y} = \frac{A_1 \bar{y}_1 + A_2 \bar{y}_2}{A_1 + A_2} = \frac{(2t \times 8t) \times 7t + (4t \times 6t) \times 3t}{2t \times 8t + 4t \times 6t} = \frac{184t^3}{40t^2} = 4.6t$$

Similarly, the *second moment*, or *moment of inertia*, of area A with respect to the y axis is

$$I_y = \int_A z^2 \, dA. \quad (\text{A.7})$$

We now define the *polar moment of inertia* of area A with respect to point O (Fig. A.8) as the integral

$$J_o = \int_A \rho^2 \, dA, \quad (\text{A.8})$$

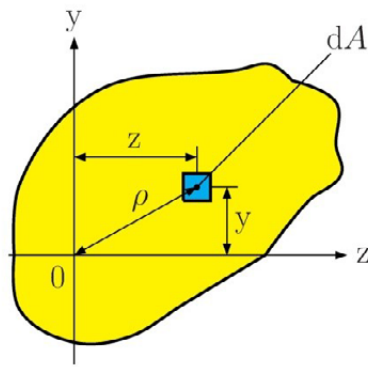


Fig. A.8

where  $\rho$  is the distance from O to the element  $dA$ . If we use SI units, the moments of inertia are expressed in  $m^4$  or  $mm^4$ .

An important relation may be established between the polar moment of inertia  $J_o$  of a given area and the moment of inertia  $I_z$  and  $I_y$  of the same area. Noting that  $\rho^2 = y^2 + z^2$ , we write

$$J_o = \int_A \rho^2 dA = \int_A (y^2 + z^2) dA = \int_A y^2 dA + \int_A z^2 dA$$

© 2013 Accenture. All rights reserved.

be > your degree

Bring your talent and passion to a global organization at the forefront of business, technology and innovation. Discover how great you can be.

Visit [accenture.com/bookboon](http://accenture.com/bookboon)

Be greater than.  
consulting | technology | outsourcing

accenture  
High performance. Delivered.



or

$$J_o = I_z + I_y \quad (\text{A.9})$$

The *radius of gyration* of area  $A$  with respect to the  $z$  axis is defined as the quantity  $r_z$ , that satisfies the relation

$$I_z = r_z^2 A \Rightarrow r_z = \sqrt{\frac{I_z}{A}} \quad (\text{A.10})$$

In a similar way, we defined the radius of gyration with respect to the  $y$  axis and origin  $O$ . We then have

$$I_y = r_y^2 A \Rightarrow r_y = \sqrt{\frac{I_y}{A}} \quad (\text{A.11})$$

$$J_o = r_o^2 A \Rightarrow r_o = \sqrt{\frac{J_o}{A}} \quad (\text{A.12})$$

Substituting for  $J_o$ ,  $I_y$  and  $I_z$  in terms of its corresponding radi of gyration in Eq. (A.9), we observe that

$$r_o^2 = r_z^2 + r_y^2 \quad (\text{A.13})$$

### Example A.03

For the rectangular area in Fig. A.9, determine (a) the moment of inertia  $I_z$  of the area with respect to the centroidal axis, (b) the corresponding radius of gyration  $r_z$ .

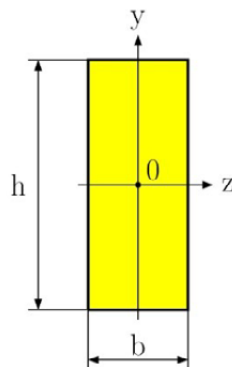


Fig. A.9

### Solution

**(a) Moment of inertia  $I_z$ .** We select, as an element area, a horizontal strip with length  $b$  and thickness  $dy$  (see Fig. A.10). For the solution we use Eq. (A.6), where  $dA = b dy$ , we have

$$I_z = \int_A y^2 \, dA = \int_{-h/2}^{+h/2} y^2 (b \, dy) = b \int_{-h/2}^{+h/2} y^2 \, dy = \frac{b}{3} [y^3]_{-h/2}^{+h/2}$$

$$I_z = \frac{b}{3} \left( \frac{h^3}{8} + \frac{h^3}{8} \right) \Rightarrow I_z = \frac{1}{12} b h^3$$

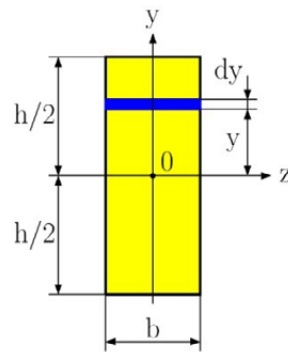


Fig. A.10

(b) **Radius of gyration**  $r_z$ . From Eq. (A.10), we have

$$r_z = \sqrt{\frac{I_z}{A}} = \sqrt{\frac{\frac{1}{12} b h^3}{b h}} = \sqrt{\frac{h^2}{12}} \Rightarrow r_z = \frac{h}{\sqrt{12}}$$

#### Example A.04

For the circular cross-section in Fig. A.11. Determine (a) the polar moment of inertia  $J_O$ , (b) the moment of inertia  $I_z$  and  $I_y$ .

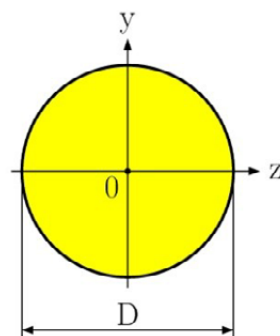


Fig. A.11

**Solution**

(a) **Polar moment of Inertia.** We select, as an element of area, a ring of radius  $\rho$  and thickness  $d\rho$  (Fig. A.12). Using Eq. (A.8), where  $dA = 2\pi\rho d\rho$ , we have

$$J_o = \int_A \rho^2 dA = \int_0^{D/2} \rho^2 2\pi\rho d\rho = 2\pi \int_0^{D/2} \rho^3 d\rho,$$

$$J_o = \frac{\delta D^4}{32}.$$

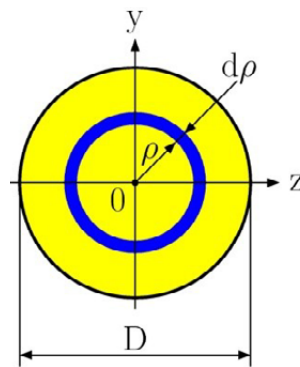
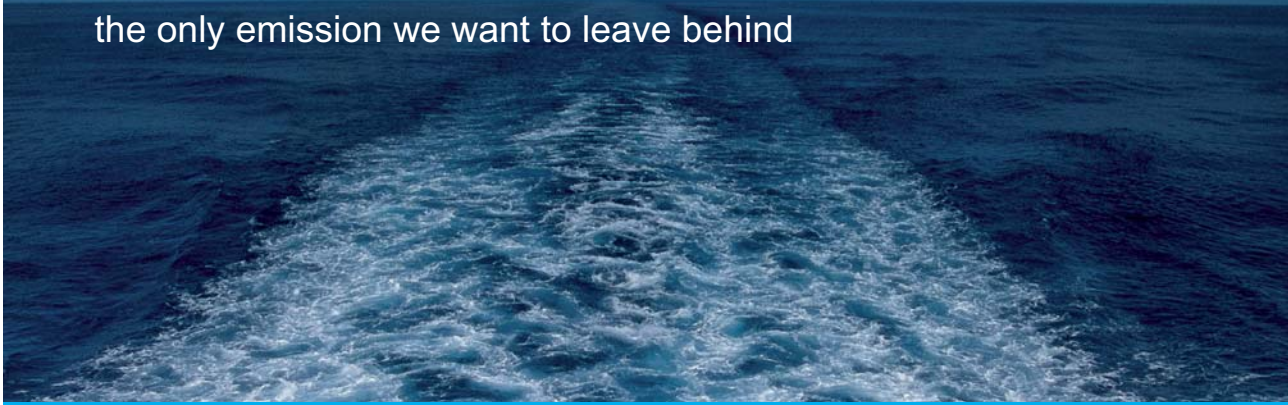


Fig. A.12

(b) **Moment of Inertia.** Because of the symmetry of a circular area  $I_z = I_y$ . Recalling Eq. (A.9), we can write

# The Wake

the only emission we want to leave behind




[Low-speed Engines](#) [Medium-speed Engines](#) [Turbochargers](#) [Propellers](#) [Propulsion Packages](#) [PrimeServ](#)

The design of eco-friendly marine power and propulsion solutions is crucial for MAN Diesel & Turbo. Power competencies are offered with the world's largest engine programme – having outputs spanning from 450 to 87,220 kW per engine. Get up front! Find out more at [www.mandieselturbo.com](http://www.mandieselturbo.com)

Engineering the Future – since 1758.

## MAN Diesel & Turbo





$$J_o = I_z + I_y = 2I_z \quad \Rightarrow \quad I_z = \frac{J_o}{2} = \frac{\pi D^4}{2}$$

$$I_z = I_y = \frac{\pi D^4}{64}.$$

### A.3 Parallel axis theorem

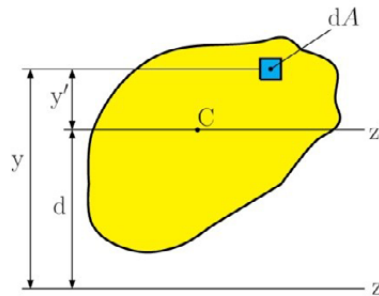


Fig. A.13

Considering the moment of inertia  $I_z$  of an area  $A$  with respect to an arbitrary  $z$  axis (Fig. A.13). Let us now draw the *centroidal*  $z'$  axis, i.e., the axis parallel to the  $z$  axis which passes through the area's centroid  $C$ . Denoting the distance between the element  $dA$  and axis passes through the centroid  $C$  by  $y'$ , we write  $y = y' + d$ . Substituting for  $y$  in Eq. (A.6), we write

$$\begin{aligned} I_z &= \int_A y^2 \, dA = \int_A (y' + d)^2 \, dA, \\ I_z &= \int_A y'^2 \, dA + 2d \int_A y' \, dA + d^2 \int_A dA, \\ I_z &= \bar{I}_{z'} + Q_{z'} + Ad^2 \end{aligned} \quad (\text{A.14})$$

where  $\bar{I}_{z'}$  is the area's moment of inertia with respect to the centroidal  $z'$  axis and  $Q_{z'}$  is the first moment of the area with respect to the  $z'$  axis, which is equal to zero since the centroid  $C$  of the area is located on that axis. Finally, from Eq. (A.14) we have

$$I_z = \bar{I}_{z'} + Ad^2 \quad (\text{A.15})$$

A similar formula may be derived, which relates the polar moment of inertia  $J_o$  of an area to an arbitrary point  $O$  and polar moment of inertia  $J_C$  of the same area with respect to its centroid  $C$ . Denoting the distance between  $O$  and  $C$  by  $d$ , we write

$$J_o = J_C + Ad^2 \quad (\text{A.16})$$

**Example A.05**

Determine the moment of inertia  $I_z$  of the area shown in Fig. A.14 with respect to the centroidal  $z$  axis.

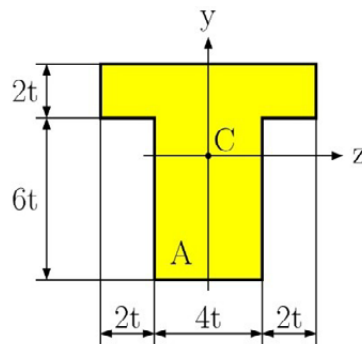


Fig. A.14

**Solution**

The first step of the solution is to locate the centroid  $C$  of the area. However, this has already been done in Example A.02 for a given area  $A$ .

We divide the area  $A$  into two rectangular areas  $A_1$  and  $A_2$  (Fig. A.15) and compute the moment of inertia of each area with respect to the  $z$  axis. Moment of inertia of the areas are

$$I_z = I_{z1} + I_{z2},$$

where  $I_{z1}$  is the moment of inertia of  $A_1$  with respect to the  $z$  axis. For the solution, we use the parallel-axis theorem (Eq. A.15), and write

$$I_{z1} = \bar{I}_z + A_1 d_1^2 = \frac{1}{12} b_1 h_1^3 + b_1 h_1 d_1^2$$

$$I_{z1} = \frac{1}{12} \times 8t \times (2t)^3 + 8t \times 2t \times (7t - 4.6t)^2$$

$$I_{z1} = 97.5 t^4$$

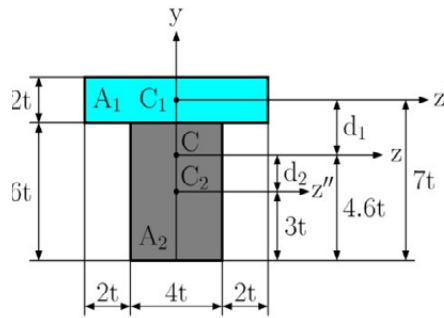


Fig. A.15

In a similarly way, we find the moment of inertia  $I_{z2}$  of  $A_2$  with respect to the  $z$  axis and write

$$I_{z2} = \bar{I}_{z''} + A_2 d_2^2 = \frac{1}{12} b_2 h_2^3 + b_2 h_2 d_2^2$$

$$I_{z2} = \frac{1}{12} \times 4t \times (6t)^3 + 4t \times 6t \times (4.6t - 3t)^2$$

$$I_{z1} = 133.4 t^4$$

The moment of inertia  $I_z$  of the area shown in Fig. A.14 with respect to the centroidal  $z$  axis is

# SMS from your computer

...Sync'd with your Android phone & number

FREE  
30 days trial!

Go to

BrowserTexting.com

and start texting from your computer!



$$I_z = I_{z_1} + I_{z_2} = 97.5t^4 + 133.4t^4 = 230.9t^4.$$

### Example A.06

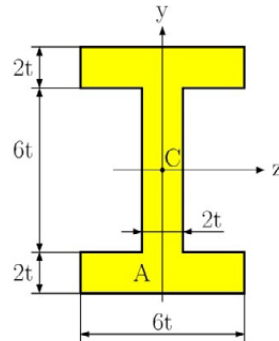


Fig. A.16

Determine the moment of inertia  $I_z$  of the area shown in Fig. A.14 with respect to the centroidal  $z$  axis and the moment of inertia  $I_y$  of the area with respect to the centroidal  $y$  axis.

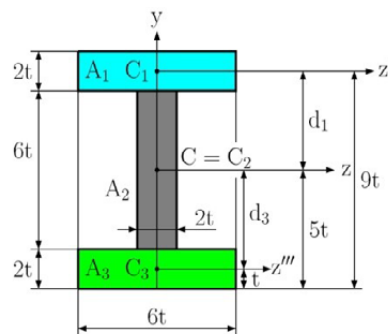


Fig. A.17

### Solution

The first step of the solution is to locate the centroid  $C$  of the area. This area has two axes of symmetry, the location of the centroid  $C$  is in the intersection of the axes of symmetry.

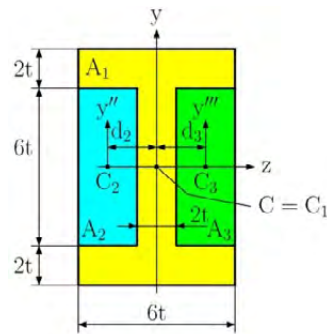


Fig. A.18

We divide the area  $A$  into three rectangular areas  $A_1$ ,  $A_2$  and  $A_3$ . The first way we can divide area  $A$  can be seen in Fig. A.17, a second way can be seen in Fig. A.18.

Solution the division of area  $A$  by Fig. A.17 (the first way) the moment of inertia  $I_z$  is

$$I_z = I_{z1} + I_{z2} + I_{z3},$$

where

$$I_{z1} = \bar{I}_z + A_1 d_1^2 = \frac{1}{12} b_1 h_1^3 + b_1 h_1 d_1^2 = \dots = 196t^4,$$

$$I_{z2} = \bar{I}_z + A_2 d_2^2 = \frac{1}{12} b_2 h_2^3 + b_2 h_2 d_2^2 = \dots = 36t^4,$$

$$I_{z3} = \bar{I}_z + A_3 d_3^2 = \frac{1}{12} b_3 h_3^3 + b_3 h_3 d_3^2 = \dots = 196t^4.$$

Resulting in

$$I_z = I_{z1} + I_{z2} + I_{z3} = 196t^4 + 36t^4 + 196t^4 = 428t^4.$$

For the moment of inertia  $I_y$  we have

$$I_y = I_{y1} + I_{y2} + I_{y3},$$

where

$$I_{y1} = \bar{I}_y = \frac{1}{12} h_1 b_1^3 = \frac{1}{12} \times 2t \times (6t)^3 = 36t^4,$$

$$I_{y2} = \bar{I}_y = \frac{1}{12} h_2 b_2^3 = \frac{1}{12} \times 6t \times (2t)^3 = 4t^4,$$

$$I_{y3} = \bar{I}_y = \frac{1}{12} h_3 b_3^3 = \frac{1}{12} \times 2t \times (6t)^3 = 36t^4.$$

Resulting in

$$I_y = I_{y1} + I_{y2} + I_{y3} = 36t^4 + 4t^4 + 36t^4 = 76t^4.$$

The solution for the division of area A according to Fig. A.18 (by the second way) the moment of inertia  $I_z$  is

$$I_z = I_{z1} - I_{z2} - I_{z3},$$

where

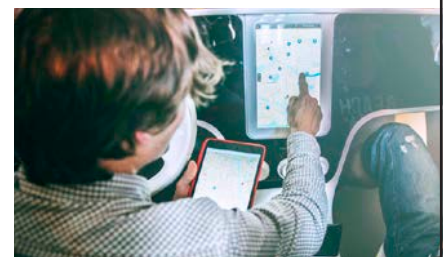
$$I_{z1} = \bar{I}_z = \frac{1}{12} b_1 h_1^3 = \frac{1}{12} \times 6t \times (10t)^3 = 500t^4,$$

$$I_{z2} = \bar{I}_z = \frac{1}{12} b_2 h_2^3 = \frac{1}{12} \times 2t \times (6t)^3 = 36t^4,$$

**YOUR WORK AT TOMTOM WILL  
BE TOUCHED BY MILLIONS.  
AROUND THE WORLD. EVERYDAY.**

Join us now on [www.TomTom.jobs](http://www.TomTom.jobs)

follow us on **LinkedIn**



**#ACHIEVEMORE**

**TOMTOM** 

$$I_{z3} = \bar{I}_z = \frac{1}{12} b_3 h_3^3 = \frac{1}{12} \times 2t \times (6t)^3 = 36t^4.$$

Resulting in

$$I_z = I_{z1} - I_{z2} - I_{z3} = 500t^4 - 36t^4 - 36t^4 = 428t^4.$$

For the moment of inertia  $I_y$  we have

$$I_y = I_{y1} - I_{y2} - I_{y3},$$

where

$$I_{y1} = \bar{I}_y = \frac{1}{12} h_1 b_1^3 = \frac{1}{12} \times 10t \times (6t)^3 = 180t^4,$$

$$I_{y2} = \bar{I}_y = \frac{1}{12} h_2 b_2^3 + h_2 b_2 d_2^2 = \frac{1}{12} \times 6t \times (2t)^3 + 6t \times 2t \times (2t)^2 = 52t^4,$$

$$I_{y3} = \bar{I}_y = \frac{1}{12} h_3 b_3^3 + h_3 b_3 d_3^2 = \frac{1}{12} \times 6t \times (2t)^3 + 6t \times 2t \times (2t)^2 = 52t^4.$$

Resulting in

$$I_y = I_{y1} - I_{y2} - I_{y3} = 180t^4 - 52t^4 - 52t^4 = 76t^4.$$

### Example A.07

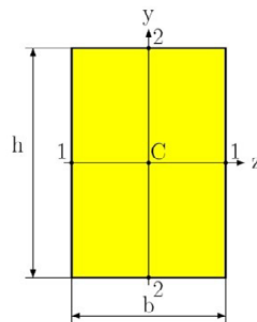


Fig. A.19

In order to solve the torsion of a rectangular cross-section in Fig. A.19, we defined (See S.P. Timoshenko and J.N. Goodier, Theory of Elasticity, 3d ed. McGraw-Hill, New York, 1969, sec. 109) the following parameters for  $b > h$ :

$$J = \gamma b^3 h, \quad (\text{A.17})$$

$$S_1 = \alpha b^2 h, \quad (\text{A.18})$$

$$S_2 = \beta b h^2, \quad (\text{A.19})$$

where parameters  $\alpha$ ,  $\beta$  and  $\gamma$  are in Tab.A.1.

The shearing stresses at point 1 and 2 are defined as

$$\tau_1 = \tau_{\max} = \frac{T}{S_1}, \quad \tau_2 = \frac{T}{S_2}, \quad (\text{A.20})$$

where  $T$  is the applied torque.

**Tab.A.1**

h/b	1	1.2	1.5	2	3	5	10	>10
$\alpha$	0.208	0.219	0.231	0.246	0.267	0.291	0.313	1/3
$\beta$	0.208	0.196	0.180	0.155	0.118	0.078	0.042	0
$\gamma$	0.1404	0.166	0.196	0.229	0.263	0.291	0.313	1/3

#### A.4 Product of Inertia, Principal Axes

Definition of product of inertia is

$$I_{yz} = \int_A y z \, dA \quad (\text{A.20a})$$

in which each element of area  $dA$  is multiplied by the product of its coordinates and integration is extended over the entire area  $A$  of a plane figure. If a cross-section area has an axis of symmetry which is taken for the  $y$  or  $z$  axis (Fig. A.19), the product of inertia is equal to zero. In the general case, for any point of any cross-section area, we can always find two perpendicular axes such that the product of inertia for these vanishes. If this quantity becomes zero, the axes in these directions are called the *principal axes*. Usually the centroid is taken as the origin of coordinates and the corresponding principal axes are then called the *centroidal principal axes*.

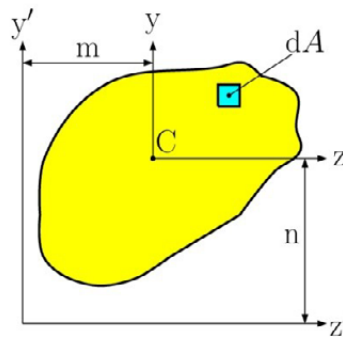


Fig. A.19a

If the product of inertia of a cross-section area is known for axes  $y$  and  $z$  (Fig. A.19a) through the centroid, the product of inertia for parallel axes  $y'$  and  $z'$  can be found from the equation

$$I_{y'z'} = I_{yz} + Amn. \quad (\text{A.20b})$$

The coordinates of an element  $dA$  for the new axes are

$$y' = y + n; \quad z' = z + m.$$

# Brain power

By 2020, wind could provide one-tenth of our planet's electricity needs. Already today, SKF's innovative know-how is crucial to running a large proportion of the world's wind turbines.

Up to 25 % of the generating costs relate to maintenance. These can be reduced dramatically thanks to our systems for on-line condition monitoring and automatic lubrication. We help make it more economical to create cleaner, cheaper energy out of thin air.

By sharing our experience, expertise, and creativity, industries can boost performance beyond expectations. Therefore we need the best employees who can meet this challenge!

The Power of Knowledge Engineering

Plug into The Power of Knowledge Engineering.  
Visit us at [www.skf.com/knowledge](http://www.skf.com/knowledge)

Hence,

$$I_{y'z'} = \int_A y'z' dA = \int_A (y+n)(z+m) dA = \int_A yz dA + \int_A mn dA + \int_A ym dA + \int_A nz dA.$$

The last two integrals vanish because C is the centroid so that the equation reduces to (A.20b).

### A.5 Strain energy for simple loads

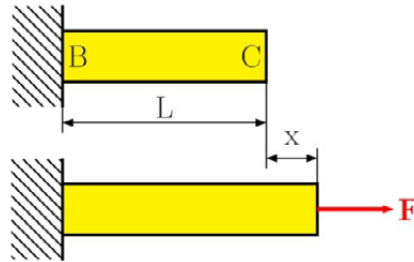


Fig. A.20

Consider a rod BC of length  $L$  and uniform cross-section area  $A$ , attached at B to a fixed support. The rod is subjected to a slowly increasing axial load  $F$  at C (Fig. A.20). The work done by the load  $F$  as it is slowly applied to the rod must result in the increase of some energy associated with the deformation of the rod. This energy is referred to as the *strain energy* of the rod. Which is defined by

$$\text{Strain energy} = U = \int_0^x F dx \quad (\text{A.21})$$

Dividing the strain energy  $U$  by the volume  $V = AL$  of the rod (Fig. A.20) and using Eq. (A.21), we have

$$\frac{U}{V} = \int_0^x \frac{F}{AL} dx \quad (\text{A.22})$$

Recalling that  $F/A$  represents the normal stress  $\sigma_x$  in the rod, and  $x/L$  represents the normal strain  $\epsilon_x$ , we write

$$\frac{U}{V} = \int_0^\epsilon \sigma_x d\epsilon_x \quad (\text{A.23})$$

The strain energy per unit volume,  $U/V$ , is referred to as the strain-energy density and will be denoted by the letter  $u$ . We therefore have

$$u = \int_0^\epsilon \sigma_x d\epsilon_x \quad (\text{A.24})$$

### A.5.1 Elastic strain energy for normal stresses

In a machine part with non-uniform stress distribution, the strain energy density  $u$  can be defined by considering the strain energy of a small element of the material with the volume  $\Delta V$ . writing

$$u = \lim_{\Delta V \rightarrow 0} \frac{\Delta U}{\Delta V} \text{ or } u = \frac{dU}{dV}. \quad (\text{A.25})$$

for the value of  $\sigma_x$  within the proportional limit, we may set  $\sigma_x = E \varepsilon_x$  in Eq. (A.24) and write

$$u = \frac{1}{2} E \varepsilon_x^2 = \frac{1}{2} \sigma_x \varepsilon_x = \frac{\sigma_x^2}{2E}. \quad (\text{A.26})$$

The value of strain energy  $U$  of the body subject to uniaxial normal stresses can be obtained by substituting Eq. (A.26) into Eq. (A.25), to get

$$U = \int \frac{\sigma_x^2}{2E} dV. \quad (\text{A.27})$$

#### Elastic strain energy under axial loading

When a rod is acted on by centric axial loading, the normal stresses are  $\sigma_x = N/A$  from Sec. 2.2. Substituting for  $\sigma_x$  into Eq. (A.27), we have

$$U = \int \frac{N^2}{2EA^2} dV \text{ or, setting } dV = A dV, \quad U = \int_0^L \frac{N^2}{2EA} dV \quad (\text{A.28})$$

If the rod has a uniform cross-section and is acted on by a constant axial force  $F$ , we then have

$$U = \frac{N^2 L}{2EA} \quad (\text{A.29})$$

#### Elastic strain energy in Bending

The normal stresses for pure bending (neglecting the effects of shear) is  $\sigma_x = My/I$  from Sec. 4. Substituting for  $\sigma_x$  into Eq. (A.27), we have

$$U = \int \frac{\sigma_x^2}{2E} dV = \int \frac{M^2 y^2}{2EI^2} dV \quad (\text{A.30})$$

Setting  $dV = dA dx$ , where  $dA$  represents an element of cross-sectional area, we have

$$U = \int_0^L \frac{M^2}{2EI} \left( \int y^2 dA \right) dx = \int_0^L \frac{M^2}{2EI} dx \quad (\text{A.31})$$

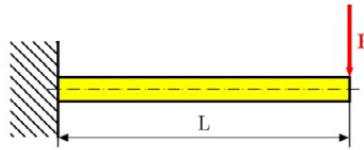
**Example A.08**

Fig. A.21

Determine the strain energy of the prismatic cantilever beam in Fig. A.21, taking into account the effects of normal stresses only.

**Solution**

The bending moment at a distance  $x$  from the free end is  $M = -F x$ . Substituting this expression into Eq. (A.31), we can write

$$U = \int_0^L \frac{M^2}{2EI} dx = \int_0^L \frac{(F x)^2}{2EI} dx = \frac{F^2 L^3}{6EI}$$

**A.5.2 Elastic strain energy for shearing stresses**

When a material is acted on by plane shearing stresses  $\tau$  the strain-energy density at a given point can

**> Apply now**

REDEFINE YOUR FUTURE  
**AXA GLOBAL GRADUATE PROGRAM 2015**

redefining / standards 

agence.cdg. © Photonistop

$$u = \int_0^{\gamma} \tau_{xy} \, d\gamma_{xy}, \quad (\text{A.32})$$

where  $\gamma_{xy}$  is the shearing strain corresponding to  $\tau_{xy}$ . For the value of  $\tau_{xy}$  within the proportional limit, we have  $\tau_{xy} = G \gamma_{xy}$ , and write

$$u = \frac{1}{2} G \gamma_{xy}^2 = \frac{1}{2} \tau_{xy} \gamma_{xy} = \frac{\tau_{xy}^2}{2G}. \quad (\text{A.33})$$

Substituting Eq. (A.33) into Eq. (A.25), we have

$$U = \int \frac{\tau_{xy}^2}{2G} \, dV. \quad (\text{A.34})$$

### Elastic strain energy in Torsion

The shearing stresses for pure torsion are  $\tau_{xy} = T\rho / J$  from Sec. 3. Substituting for  $\tau_{xy}$  into Eq. (A.27), we have

$$U = \int \frac{\tau_{xy}^2}{2G} \, dV = \int \frac{T^2 \tilde{r}^2}{2GEJ^2} \, dV \quad (\text{A.35})$$

Setting  $dV = dA \, dx$ , where  $dA$  represents an element of the cross-sectional area, we have

$$U = \int_0^L \frac{T^2}{2GJ^2} \left( \int \rho^2 dA \right) dx = \int_0^L \frac{T^2}{2GJ} \, dx \quad (\text{A.36})$$

In the case of a shaft of uniform cross-section acted on by a constant torque  $T$ , we have

$$U = \frac{T^2 L}{2GJ} \quad (\text{A.37})$$

### Elastic strain energy in transversal loading

If the internal shear at section  $x$  is  $V$ , then the shear stress acting on the volume element, having a length of  $dx$  and an area of  $dA$ , is  $\tau = VQ / It$  from Sec. 4. Substituting for  $\tau$  into Eq. (A.27), we have

$$U = \int \frac{\tau^2}{2G} \, dV = \int \frac{1}{2G} \left( \frac{VQ}{It} \right)^2 dA \, dx = \int_0^L \frac{V^2}{2GI^2} \left( \int \frac{Q^2}{t^2} dA \right) dx \quad (\text{A.38})$$

The integral in parentheses is evaluated over the beam's cross-sectional area. To simplify this expression we define the form factor for shear

$$f_s = \frac{A}{I^2} \int \frac{Q^2}{t^2} dA \quad (\text{A.39})$$

Substituting Eq. (A.39) into Eq. (A.38), we have

$$U = \int_0^L f_s \frac{V^2}{2GA} dx \quad (\text{A.40})$$

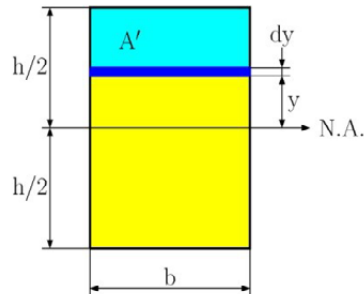


Fig. A.22

The form factor defined by Eq. (A.39) is a dimensionless number that is unique for each specific cross-section area. For example, if the beam has a rectangular cross-section with a width  $b$  and height  $h$ , as in Fig. A.22, then

$$t = b, \quad A = b h, \quad I = \frac{1}{12} b h^3$$

$$Q = \bar{y}' A' = \left( y + \frac{\frac{h}{2} - y}{2} \right) b \left( \frac{h}{2} - y \right) = \frac{b}{2} \left( \frac{h^2}{4} - y^2 \right)$$

Substituting these terms into Eq. (A.39), we get

$$f_s = \frac{bh}{\left( \frac{1}{12} bh^3 \right)^2} \int_{-h/2}^{+h/2} \frac{b^2}{4b^2} \left( \frac{h^2}{4} - y^2 \right) b dy = \frac{6}{5} \quad (\text{A.41})$$

### Example A.09

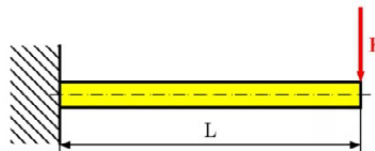


Fig. A.23

Determine the strain energy in the cantilever beam due to shear if the beam has a rectangular cross-section and is subject to a load  $F$ , Fig. A.23. assume that  $EI$  and  $G$  are constant.

**Solution**

From the free body diagram of the arbitrary section, we have

$$V(x) = F.$$

Since the cross-section is rectangular, the form factor  $f_s = \frac{6}{5}$  from Eq. (A.41) and therefore Eq. (A.40)

becomes

$$U_{shear} = \int_0^L \frac{6}{5} \frac{F^2}{2GA} dx = \frac{3}{5} \frac{F^2 L}{GA}$$

Using the results of Example A.08, with  $A = b h$ ,  $I = \frac{1}{12} b h^3$ , the ratio of the shear to the bending strain energy is

$$\frac{U_{shear}}{U_{bending}} = \frac{\frac{3}{5} \frac{F^2 L}{GA}}{\frac{F^2 L^3}{6EI}} = \frac{3}{10} \frac{h^2}{L^2} \frac{E}{G}$$

## LIGS University

based in Hawaii, USA

is currently enrolling in the  
Interactive Online **BBA, MBA, MSc,**  
**DBA and PhD** programs:

- ▶ enroll **by October 31st, 2014** and
- ▶ **save up to 11%** on the tuition!
- ▶ pay in 10 installments / 2 years
- ▶ Interactive **Online** education
- ▶ visit [www.ligsuniversity.com](http://www.ligsuniversity.com) to find out more!

Note: LIGS University is not accredited by any nationally recognized accrediting agency listed by the US Secretary of Education. More info [here](http://www.ligsuniversity.com).



Since  $G = E / 2(1+n)$  and  $n = 0.5$ , then  $E = 3G$ , so

$$\frac{U_{shear}}{U_{bending}} = \frac{3}{10} \frac{h^2}{L^2} \frac{3G}{G} = \frac{9}{10} \frac{h^2}{L^2}$$

It can be seen that the result of this ratio will increase as  $L$  decreases. However, even for short beams, where, say  $L = 5h$ , the contribution due to shear strain energy is only 3.6% of the bending strain energy. For this reason, the shear strain energy stored in beams is usually neglected in engineering analysis.

# References

Hibbeler, R.C.: Mechanics of Materials. SI Second Edition, Prentice-Hall, Inc., 2005, ISBN 0-13-191345-X

Beer, F.P., Johnston, E.R. Jr., Dewolf, J.T., Mazurek, D.F.: Mechanics of Materials, Sixth Edition, McGraw-Hill, 2012, ISBN 978-0-07-338028-5

Frydrýšek, K., Adámková, L.: Mechanics of Materials 1 (Introduction, Simple Stress and Strain, Basic of Bending), Faculty of Mechanical Engineering, VŠB - Technical University of Ostrava, Ostrava, ISBN 978-80-248-1550-3, Ostrava, 2007, Czech Republic, pp. 179

Halama, R., Adámková, L., Fojtík, F., Frydrýšek, K., Šofer, M., Rojíček, J., Fusek, M.: Pružnost a pevnost, VŠB – Technical University of Ostrava, Ostrava 2012, 254 pp., [<http://mi21.vsb.cz/modul/pruznost-pevnost>] (in Czech)

Puchner, O., Kamenský, A., Syč-Milý, J., Tesař, S.: Pružnosť a pevnosť I, SVŠT Bratislava, ISBN 80-227-0227-7, 1990. (in Slovak)

Puchner, O., Kamenský, A., Syč-Milý, J., Tesař, S.: Pružnosť a pevnosť II, 2.edition, SVŠT Bratislava, ISBN 80-227-0169-6, 1989. (in Slovak)

Syč-Milý, J. a kol.: Pružnosť a pevnosť: Riešené príklady, Alfa, Bratislava, 1988. (in Slovak)

Timoshenko, S.: Strength of Materials, Elementary Theory and Problems, Part I, 2nd Edition, D. Van Nostrand Co., New York, NY, (1940)

Timoshenko, S.: Strength of Materials, Advanced Theory and Problems, Part II, 2nd Edition, D. Van Nostrand Co., New York, NY, (1947)

Trebuňa, F., Šimčák, F., Jurica, V.: Pružnosť a pevnosť I., 1. edition, Viena, Košice, ISBN 80-7099-477-0, 2000 (in Slovak)

Trebuňa, F., Šimčák, F., Jurica, V.: Pružnosť a pevnosť II., 1. edition, Viena, Košice, ISBN 80-7099-478-9, 2000 (in Slovak)

Trebuňa, F., Šimčák, F., Jurica, V.: Príklady a úlohy z pružnosti a pevnosti 1., 1. edition, Viena, Košice, ISBN 80-7099-593-9, 2000 (in Slovak)

Trebuňa, F., Šimčák, F., Jurica, V.: Príklady a úlohy z pružnosti a pevnosti 2., 1. edition, Technical University in Košice, Košice, ISBN 80-7099-594-7, 2001 (in Slovak)

Ralston, A., Rabinowitz, P.: First Course in Numerical Analysis, Second Edition, 1978, Republished 2001 by Dover, Mineola, N.Y.

Gibson, L.J., Ashby, M.F.: Cellular Solids, First Paperback Edition, Cambridge University Press, 1999, ISBN 0 521 499 119

## TURN TO THE EXPERTS FOR **SUBSCRIPTION** CONSULTANCY

Subscribe is one of the leading companies in Europe when it comes to innovation and business development within subscription businesses.

We innovate new subscription business models or improve existing ones. We do business reviews of existing subscription businesses and we develop acquisition and retention strategies.

Learn more at [linkedin.com/company/subscribe](https://www.linkedin.com/company/subscribe) or contact  
Managing Director Morten Suhr Hansen at [mha@subscribe.dk](mailto:mha@subscribe.dk)

**SUBSCR**✓**BE** - to the future